

November 6-10, 2006 –Valencia

4-th Concept and MDI issues

Alexander Mikhailichenko

Cornell University, LEPP, Ithaca, NY 14853

For the 4th -Concept

see

<http://physics.uoregon.edu/~lc/wwstudy/concepts/>

Basic principles

Iron adds to the field value ~15% only and could be omitted (field outside of long solenoid is zero).

Homogeneity can be restored by adding current at the ends of main solenoid.

Second solenoid closes the flux.

Muons can be identified with **dual readout calorimeter** scheme in more elegant way

Usage of dual solenoidal system plus end wall current system allows:

- 1) Strict confinement of magnetic field inside limited region
- 2) Spectroscopy of muons in magnetic field between solenoids

Modular design allows easy modification, re-installations...

All these allow lightweight detector having flexible functionality and remarkable accuracy

No problem with push-pull concept under discussion now

Detector carries final focus optics

Total stored energy ~2.77 GJ

FF optics has trimming possibilities-mechanical and electric

12.9 m

Frame holds solenoids
And all other elements

WALL OF COILS CAN BE RELOCATED IN Z

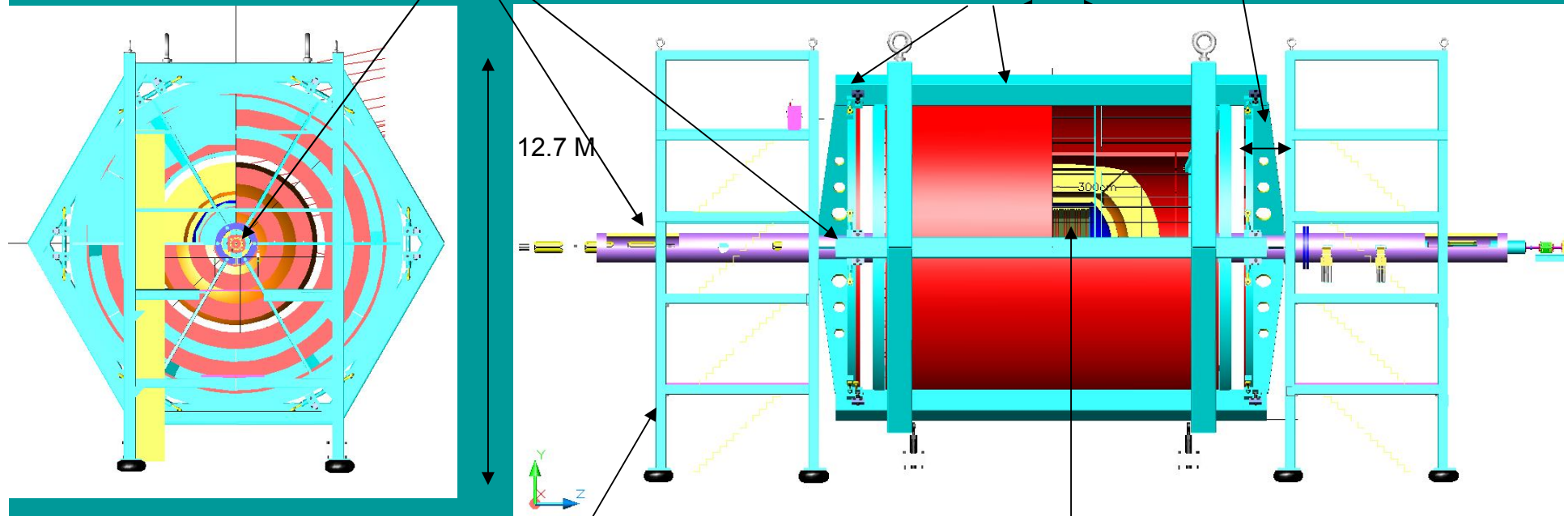

Front end equipment hut

$L^* \approx 3m$

~30 m

Total weight majorettes by 300 tons in optimistic estimation

Wall of coils

Axis-symmetrical system of coils restricts propagation of field out of detector

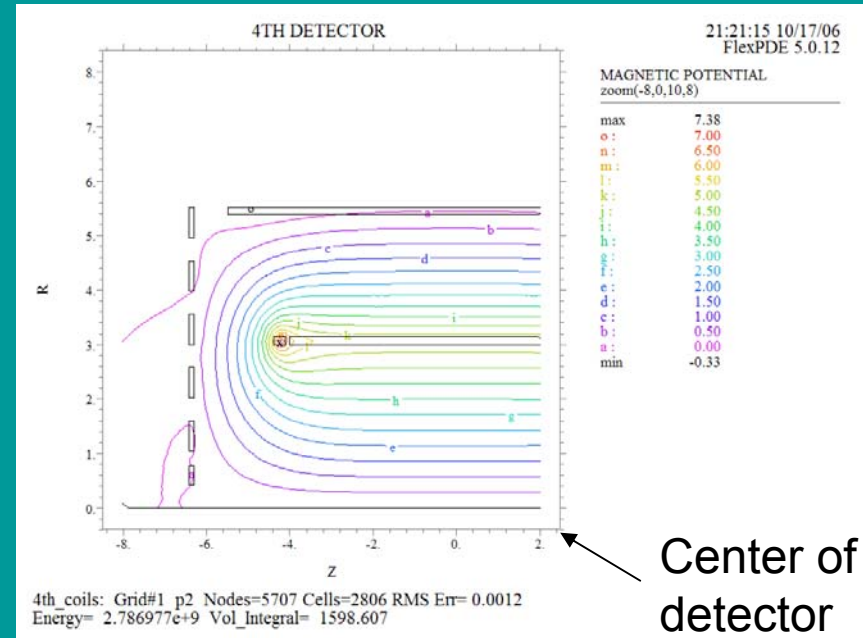
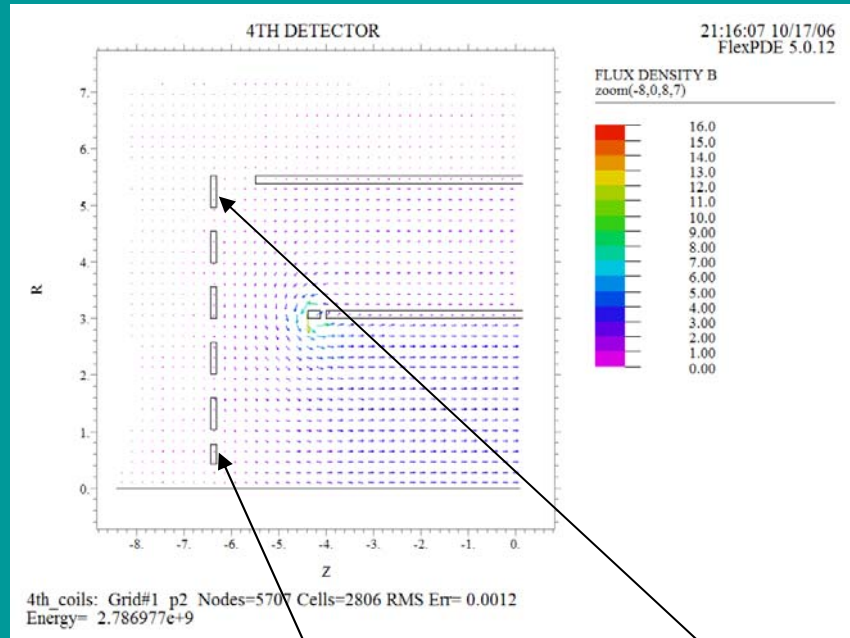

All side coils are **room-temperature** ones;
Current density: 1; 8; 4.2; 3.3; 3.7; 1.7 A/mm²
Forces :1.75; 102; 131; 135; 111; 10 tons

In future optimization all coils will have ~same current density; water cooled (required only for #2)

Field outside detector can be zeroed to any level by proper current distribution;
Coils can be fixed easily at the end plates

(Effective CMS Current density ~14.2 A/mm² , meanwhile typical practical current density in directly cooled SC wire is 1500A/mm² for 3.5 T field--- lot to think about)

Deformations of end plates

Maximal deformation is in the middle of holder. It is below 5mm.

Active movers of FF lenses will compensate this effect easily.

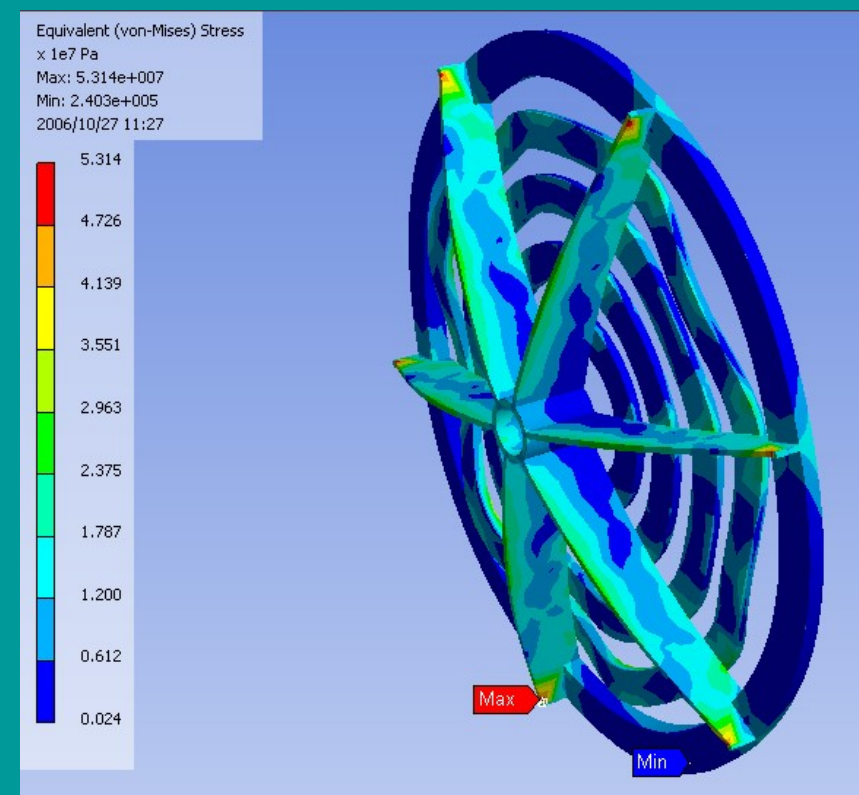
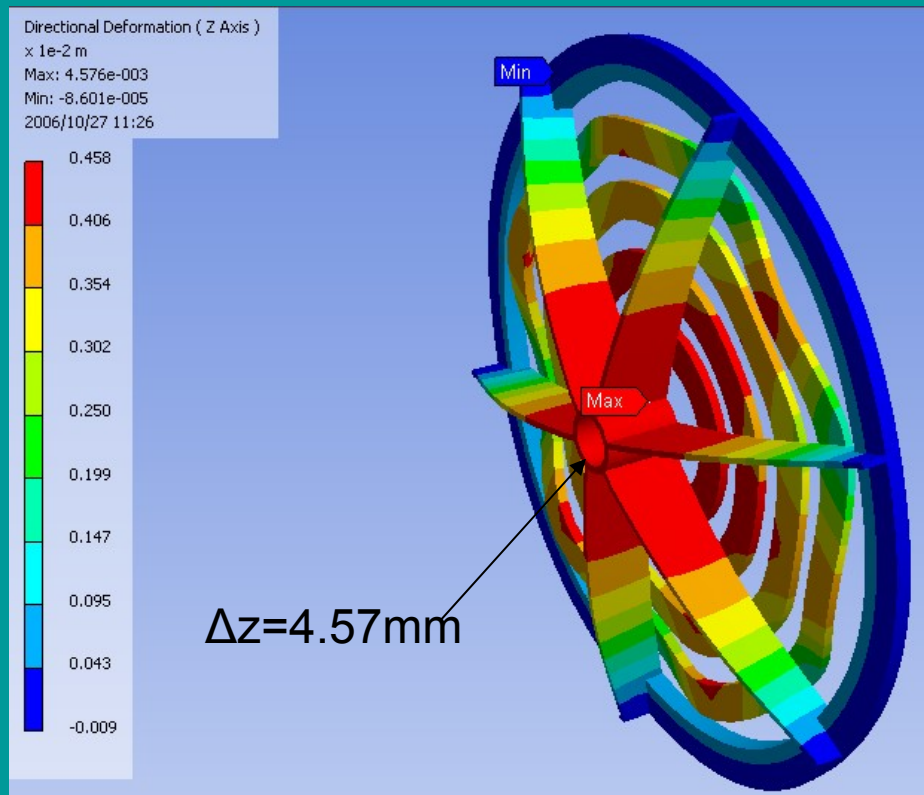

Deformation of FF holder is in z-direction.

Reinforcement can be done as well.

Calculated by V.Medjidzade

Calculations carried by B.Wands also

For homogeneity the current density in main coil has longitudinal dependence, like $J=J_0*(1+a*z^2)$

In simplest case it is a Helmholtz-type system with increased current at the ends.

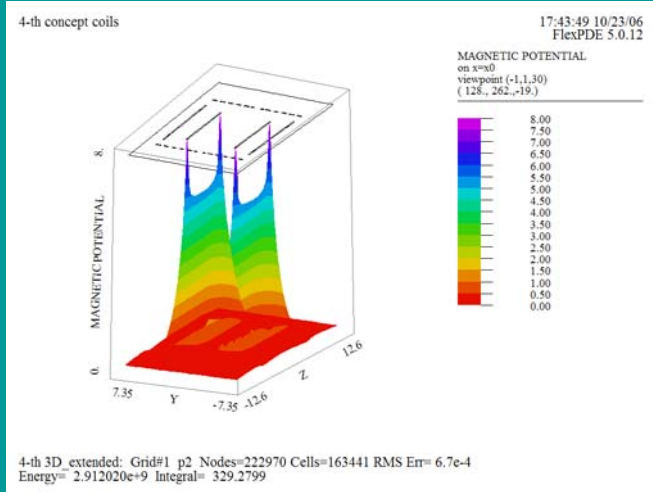

Magnetic potential

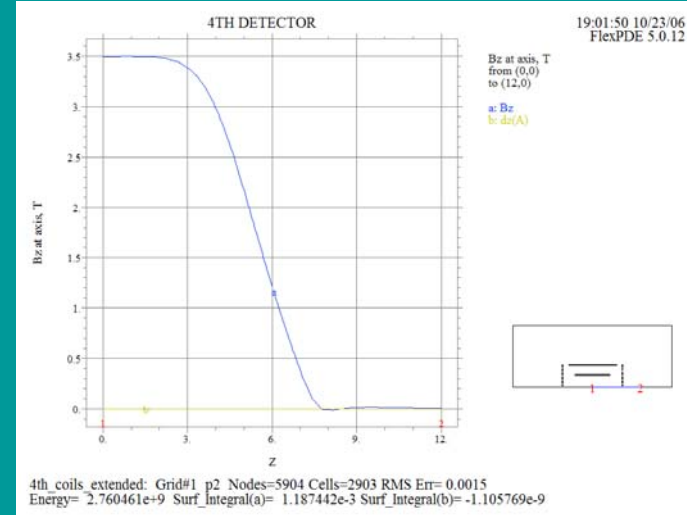

Stored energy is ~2.77GJ for 3.5T axial field

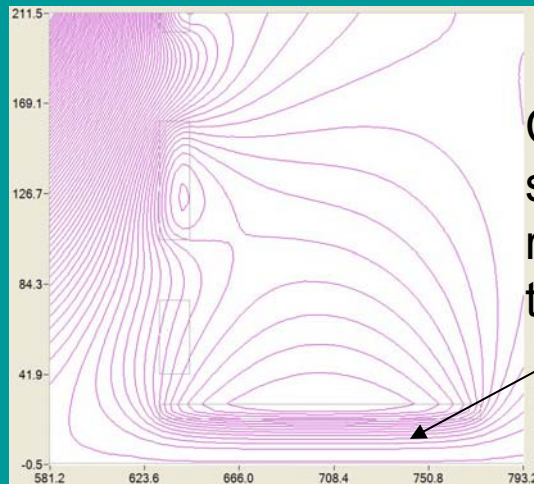

Compensational solenoid deals with residual part of transverse kick

Field used for spectrometry of muons

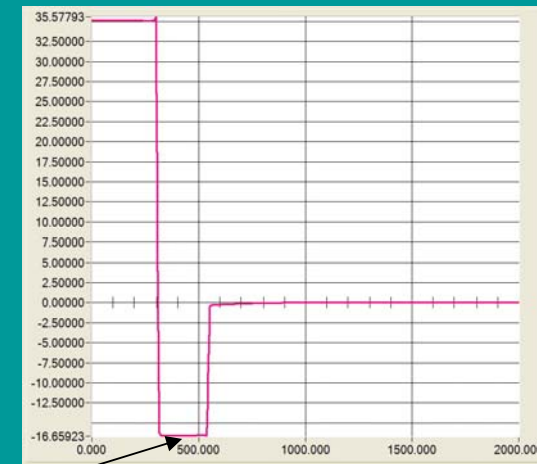

Field across detector

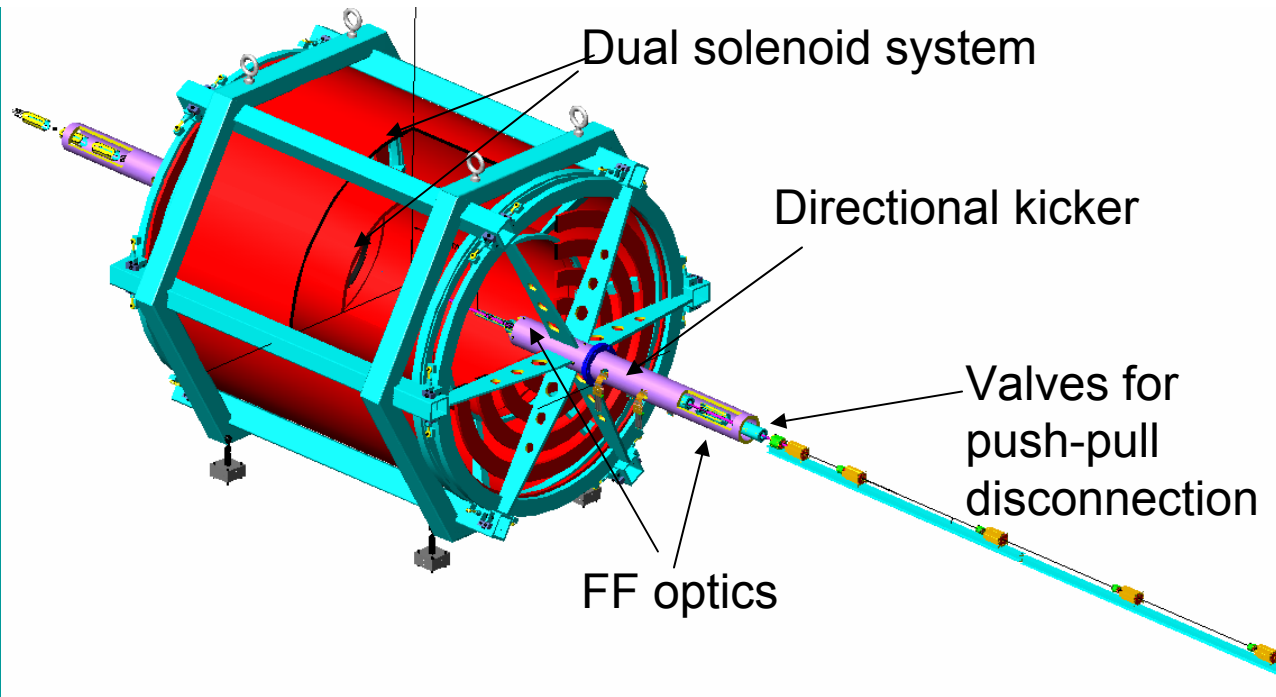

Final focus optics, mounted inside a cylinder attached to the detector by consoles.

This reduces influence of ground motion.

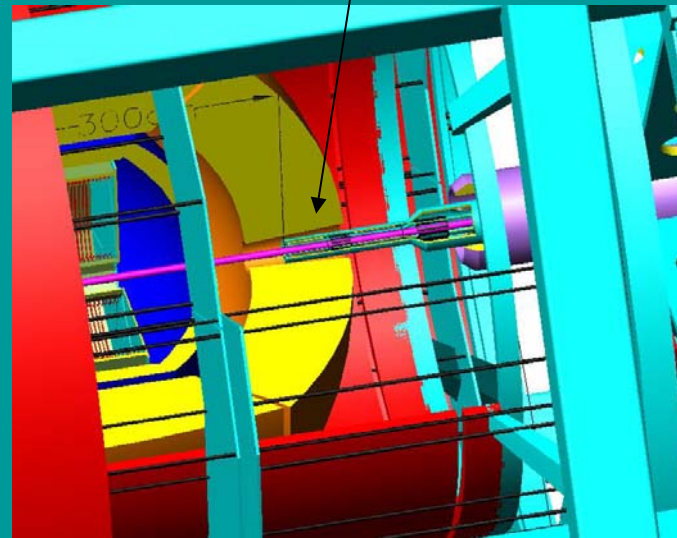
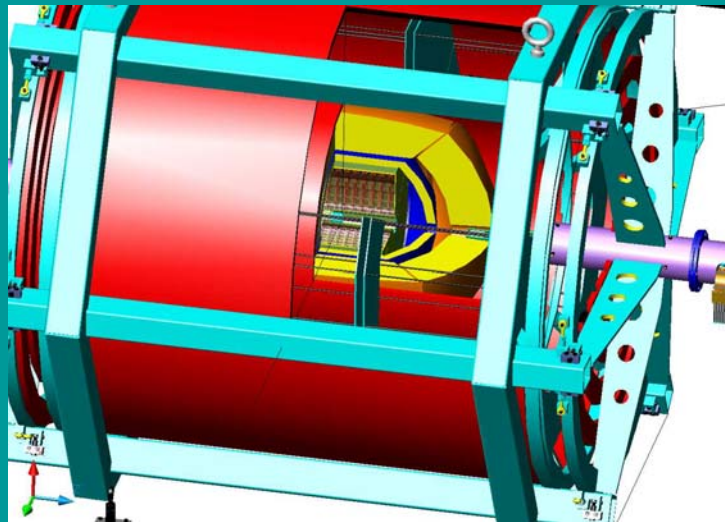

14 mrad crossing angle can be accommodated by 4th CD frame

Active system supposed to be in use for moving the lenses. It eliminates influence of asymmetric deformations induced by ponderomotive forces and ground motion

In addition to standard optics we are considering the adiabatic final focusing with local compensation of chromaticity and residual dispersion at IP

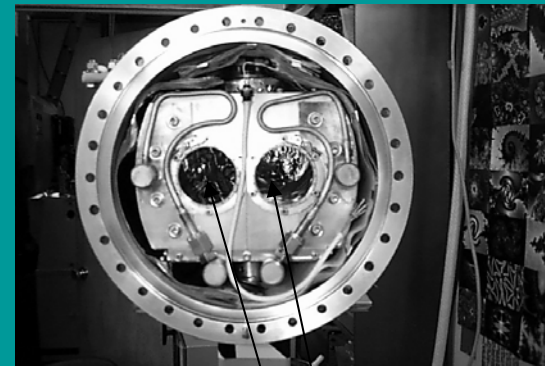
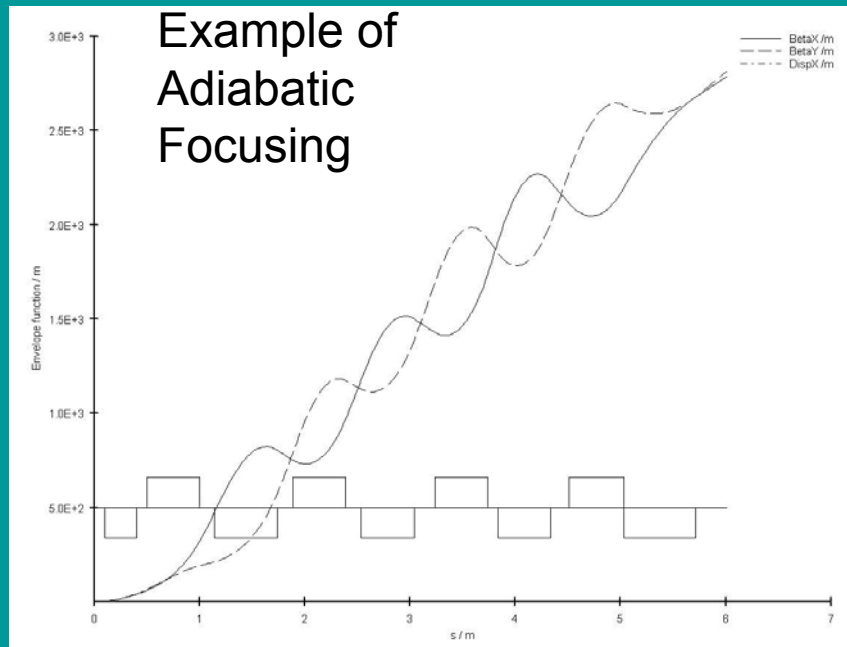

Dual bore SC quadrupole developed and tested at Cornell.

Distance between room temperature walls ~25mm

Septum between SC apertures ~5 mm

$$\text{Chromaticity} \cong -\frac{1}{4\pi(HR)} \int G(s)\beta(s)ds \quad \text{gradient changes, } \beta \sim \text{const}$$

Residual chromaticity at IP is a positive factor for monochromatization

Detector end-electronics installed on the separately standing console.

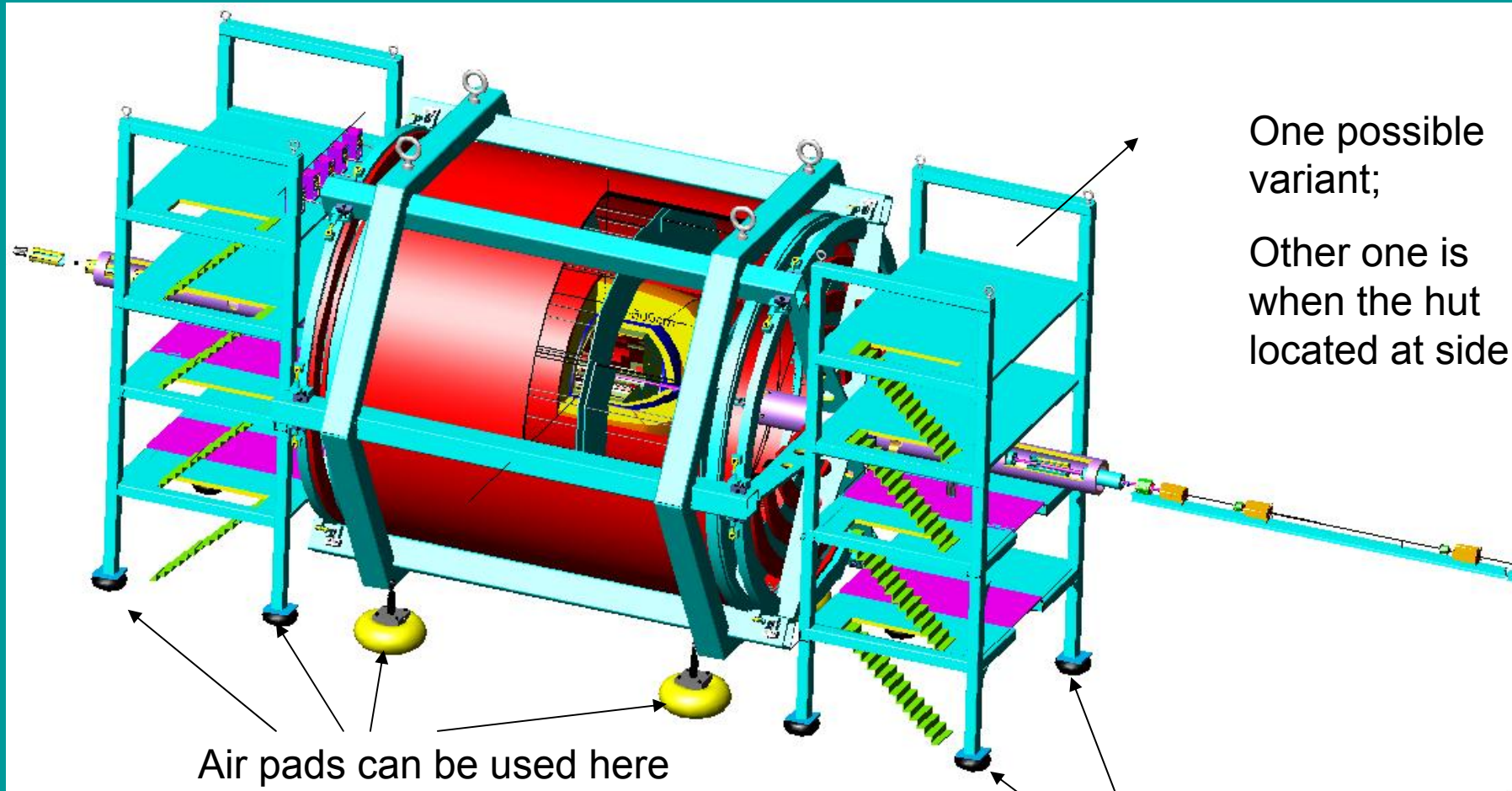

During movement some restraints can be applied

Console (hut) has anti-vibration footers.

BASIC COMPONENTS OF DETECTOR

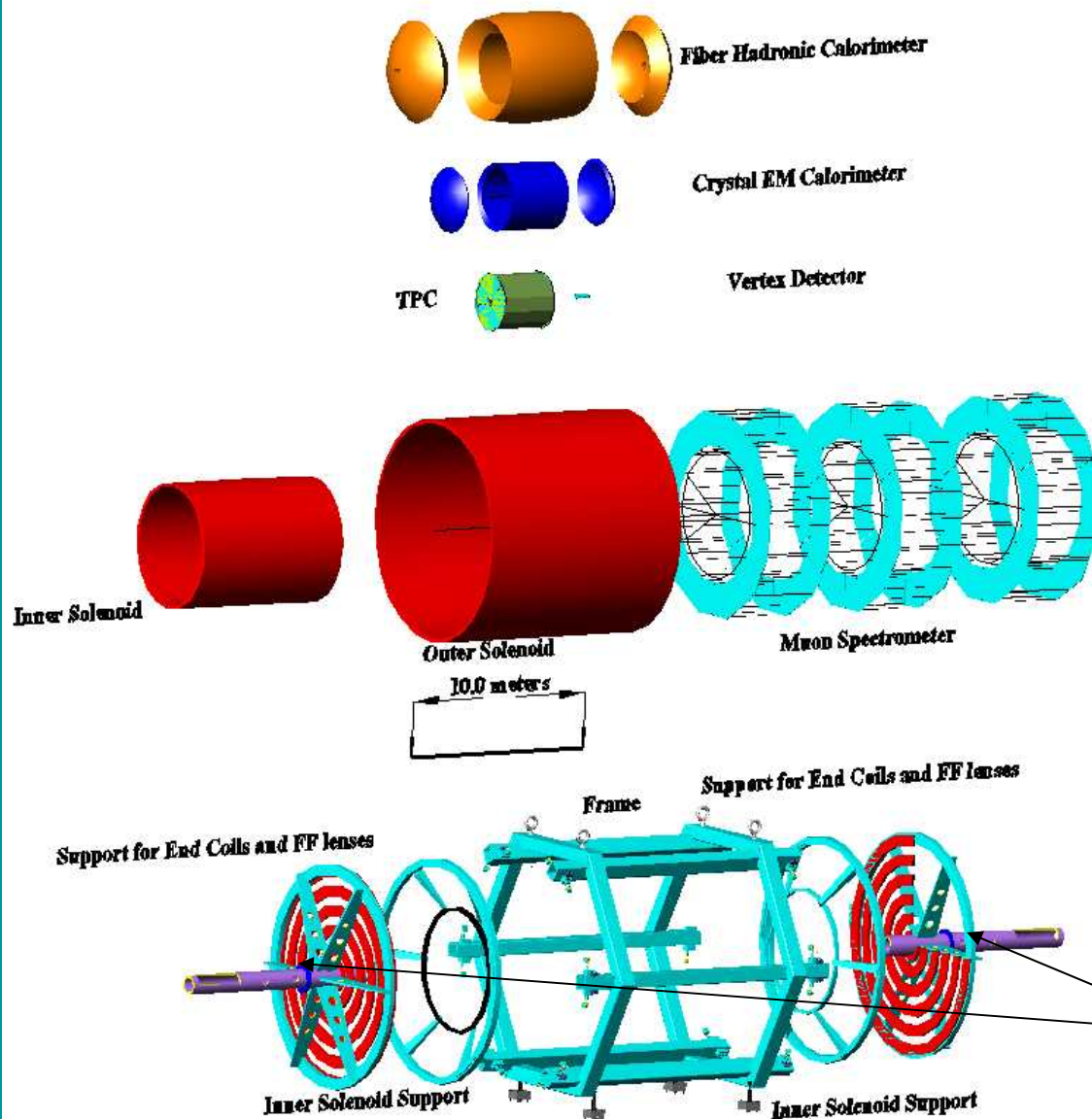

Detector is well structured-modular

If collisions with different energies of e^+e^- beams can give any advantage, detector can be modified to asymmetric one

Here *background* reactions can be shifted in z from IP;

Useful Higgs created at IP

(Vice versa with Asymmetric B-factory)

Additional flanges

Installation in push-pull scenario

Places for disconnection

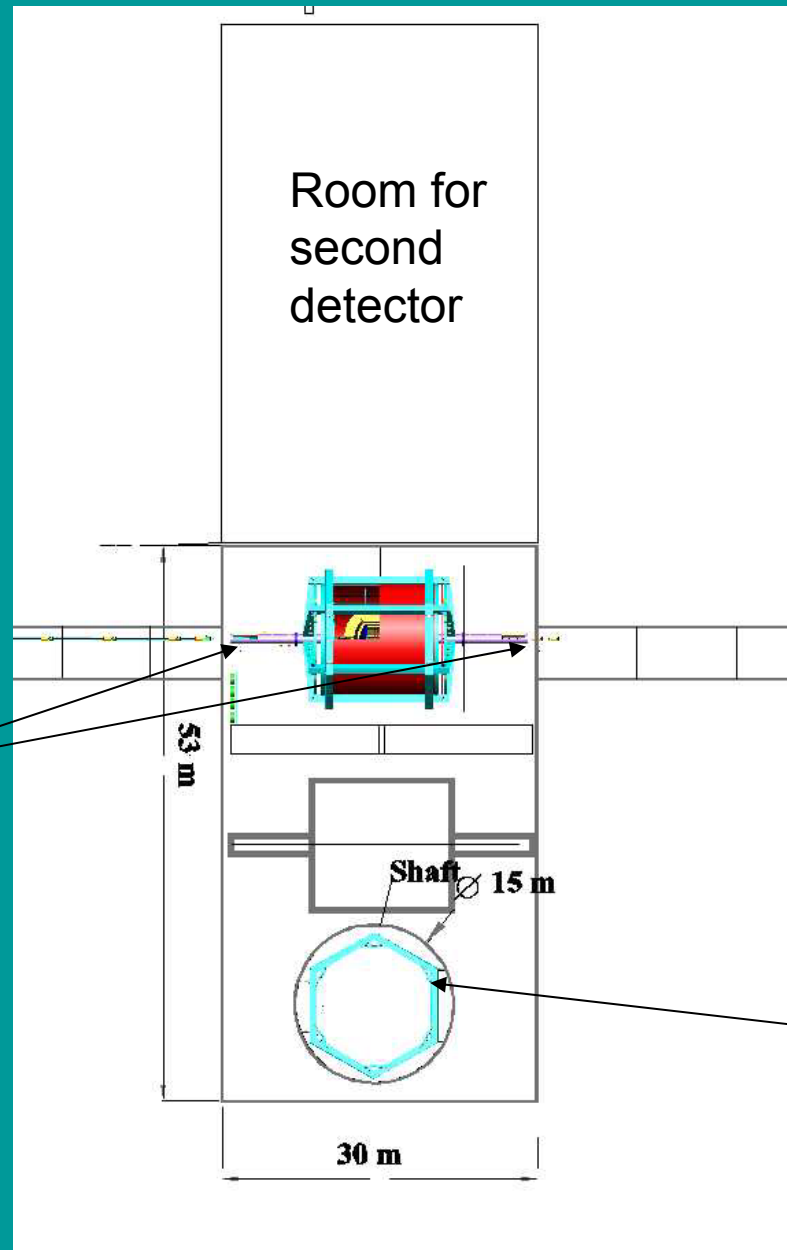

Coils installed in frame in Upper building

Concept of detector cave

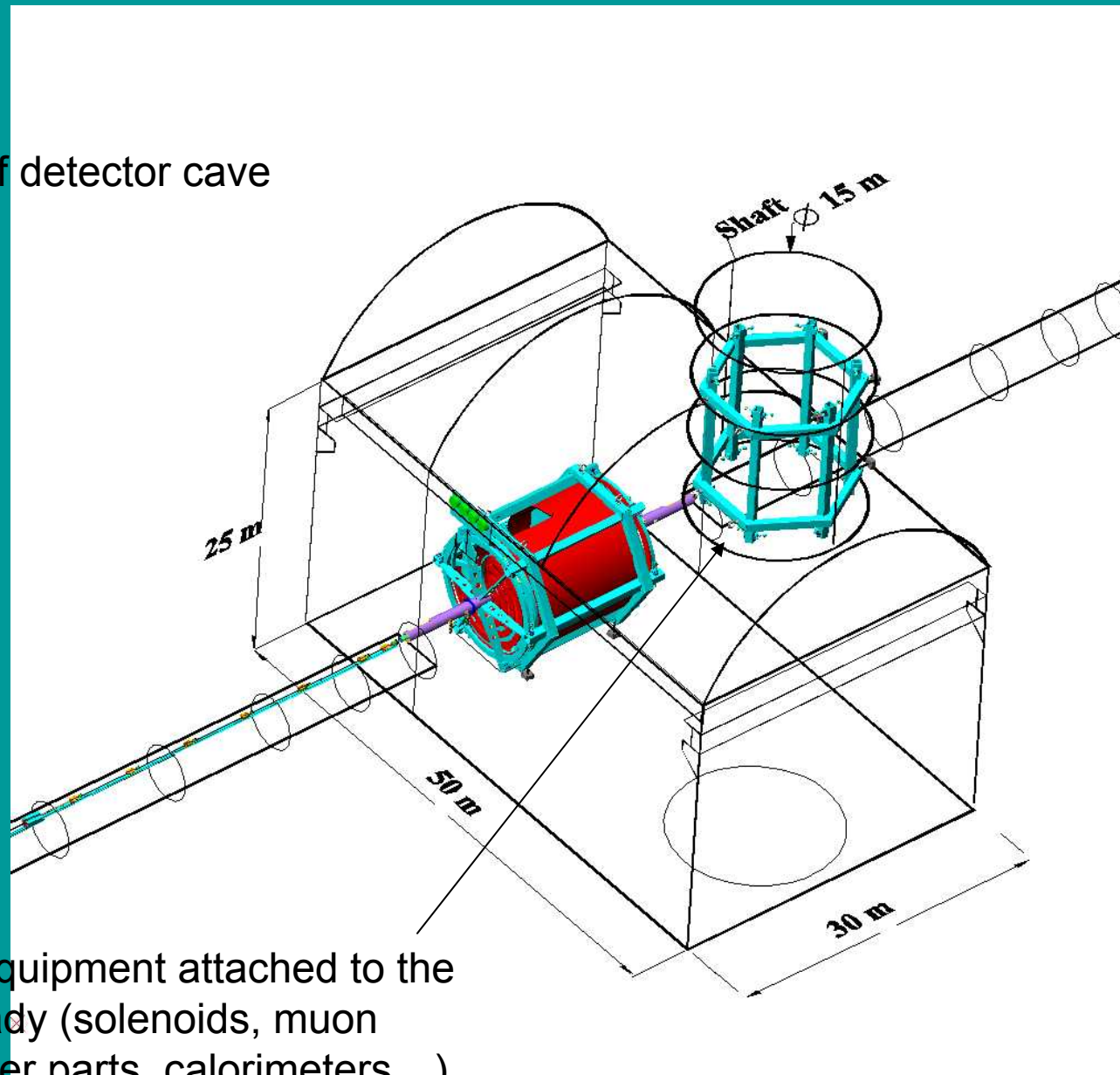

Mostly of equipment attached to the frame already (solenoids, muon spectrometer parts, calorimeters...)

Pretty modest

Directional Kicker scheme for head-on collisions

Detector accommodates 14 mrad optics.

We also working for head on collision scheme

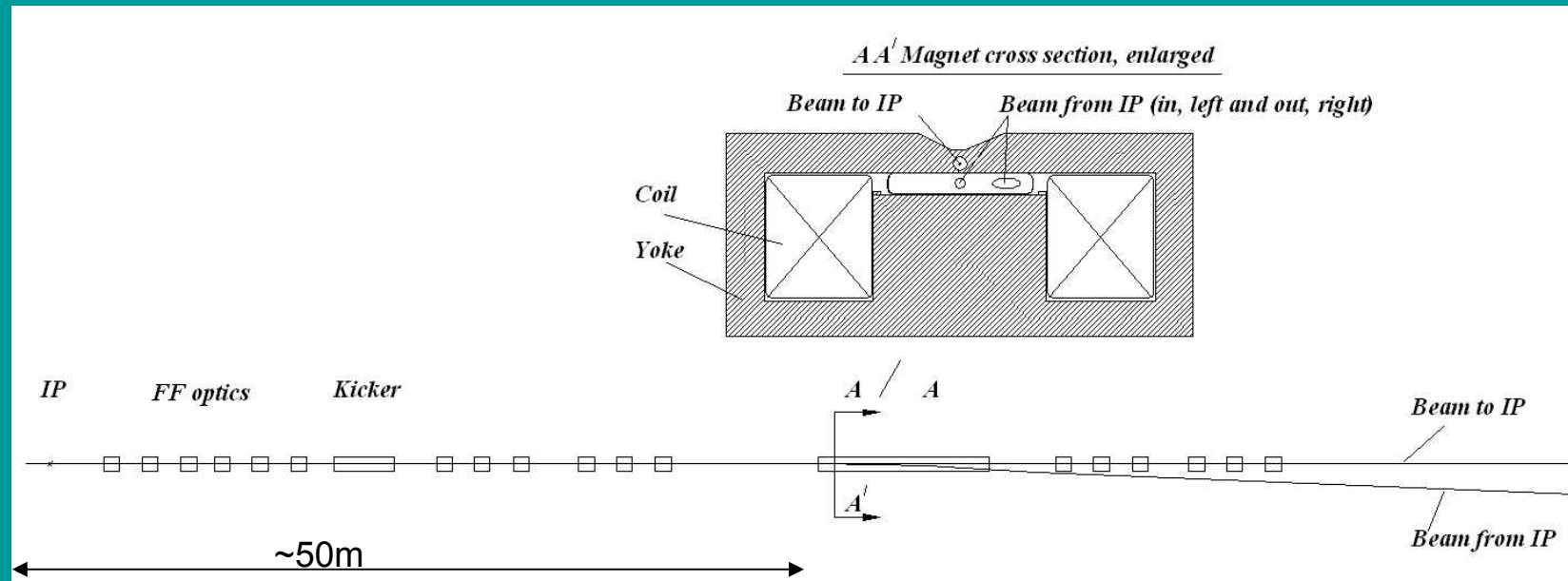

Zero crossing angle scheme, top view. Kicker operates in vertical direction (out from the view to the plane of Figure). Distance between kicker and the Lambertson/Picconi magnet ~40m. Scaled cross section of this magnet is represented in upper part of Figure.

**Kicker is TEM type, so it interacts with counter-propagating beam ;
So the beam kicked by electrical **and** magnetic field**

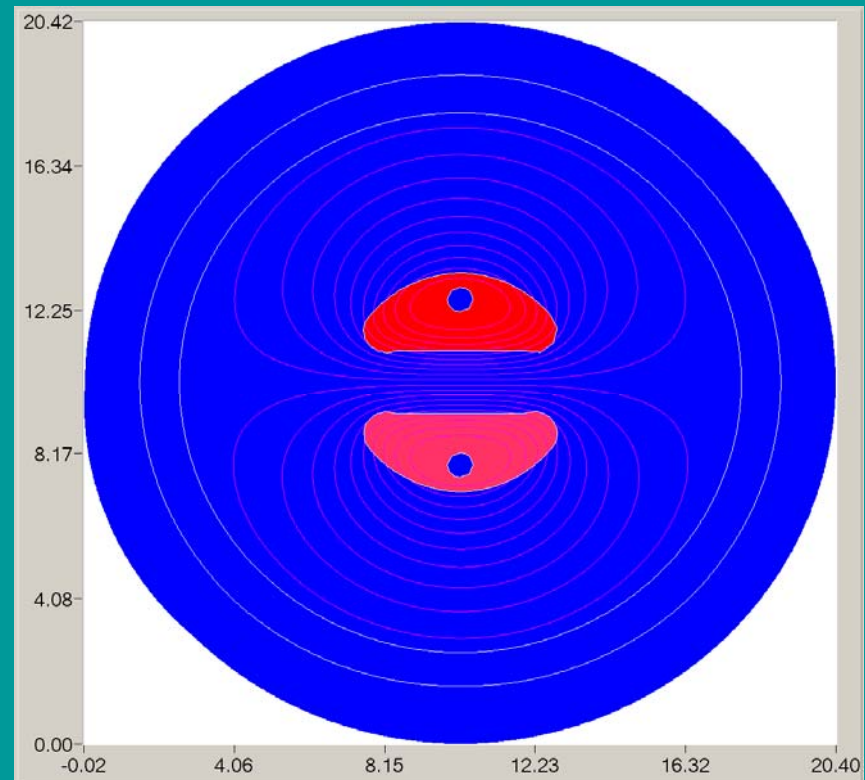
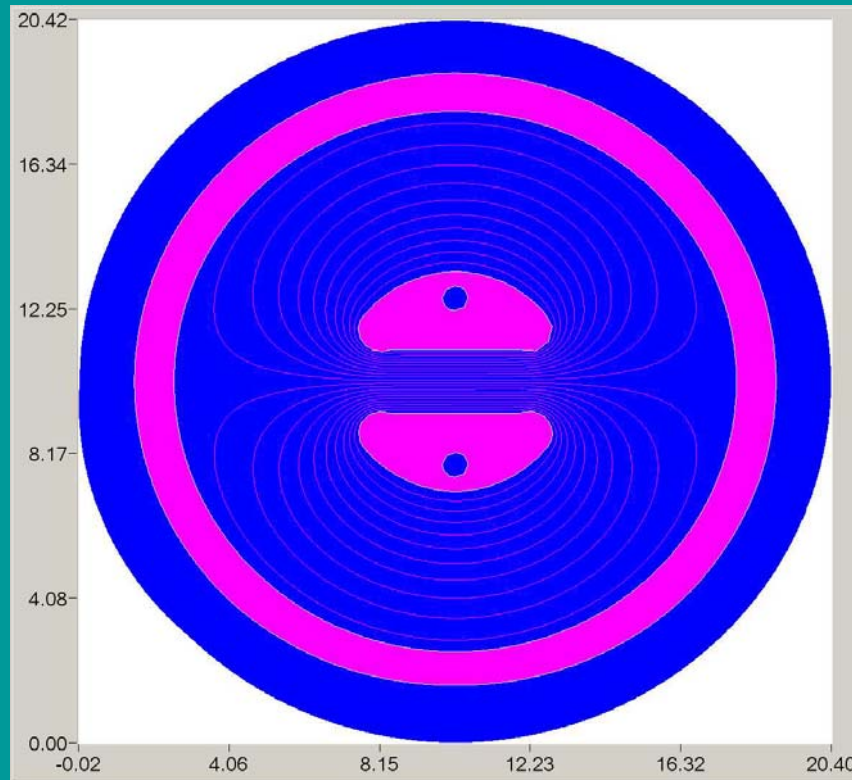

Magnetic field between current sheets does not depend on distance between them if they are wide enough. This opens a possibility for relatively long pulse, ~1msec scale

Pulse duty is, slightly longer than the beam train, ~1.2 msec

For 20 sigma
$$\vartheta \cong \frac{20\sigma_{used}}{L} \cong \frac{2\int Hdl}{(HR)}$$

Perturbation of emittance $\Delta\gamma\mathcal{E} \propto a \cdot r_0 N$ HR=3 10^6 kG cm (1 TeV)

$$\sigma_{used} \cong \sqrt{\frac{\Delta\gamma\mathcal{E} \cdot \beta}{\gamma}} \cong \sqrt{\frac{3 \cdot 10^{-5} \cdot 100}{2 \cdot 10^6}} \cong 4 \cdot 10^{-5} m \cong 40 \mu m$$

For $L \approx 40$ m, $20\sigma_{used} \cong 8 \cdot 10^{-2} cm$, (i.e. 0.8mm),

$$\int Hdl \cong (HR)\vartheta \cong 150 kG \cdot cm \quad H \odot 0.5 kG \text{ for } 300 \text{ cm long kicker.}$$

For impedance ~50Ω, E~3MV/m; For 1 cm size it comes to 30kV, current ⊙ 0.6kA

(Power in a beam)= $2 \times 10^{10} \times 2820 \times 5 \times 250 \times 10^9 \times 1.6 \times 10^{-19} = 11.28$ MW;

10% SR comes to ~1MW of radiation from IP
$$\left(\frac{\Delta E}{E}\right)_{max} \cong \frac{8\sqrt{\pi}}{3} \cdot \frac{r_0^3 \gamma N^2}{\sigma_x^2 \sigma_s}$$

(Spot at septum location)= $50m \cdot 1/\gamma = 50000mm \cdot 2 \cdot 10^{-6} \odot 0.1$ mm

4-th CD fits into any scenario of FF arrangements

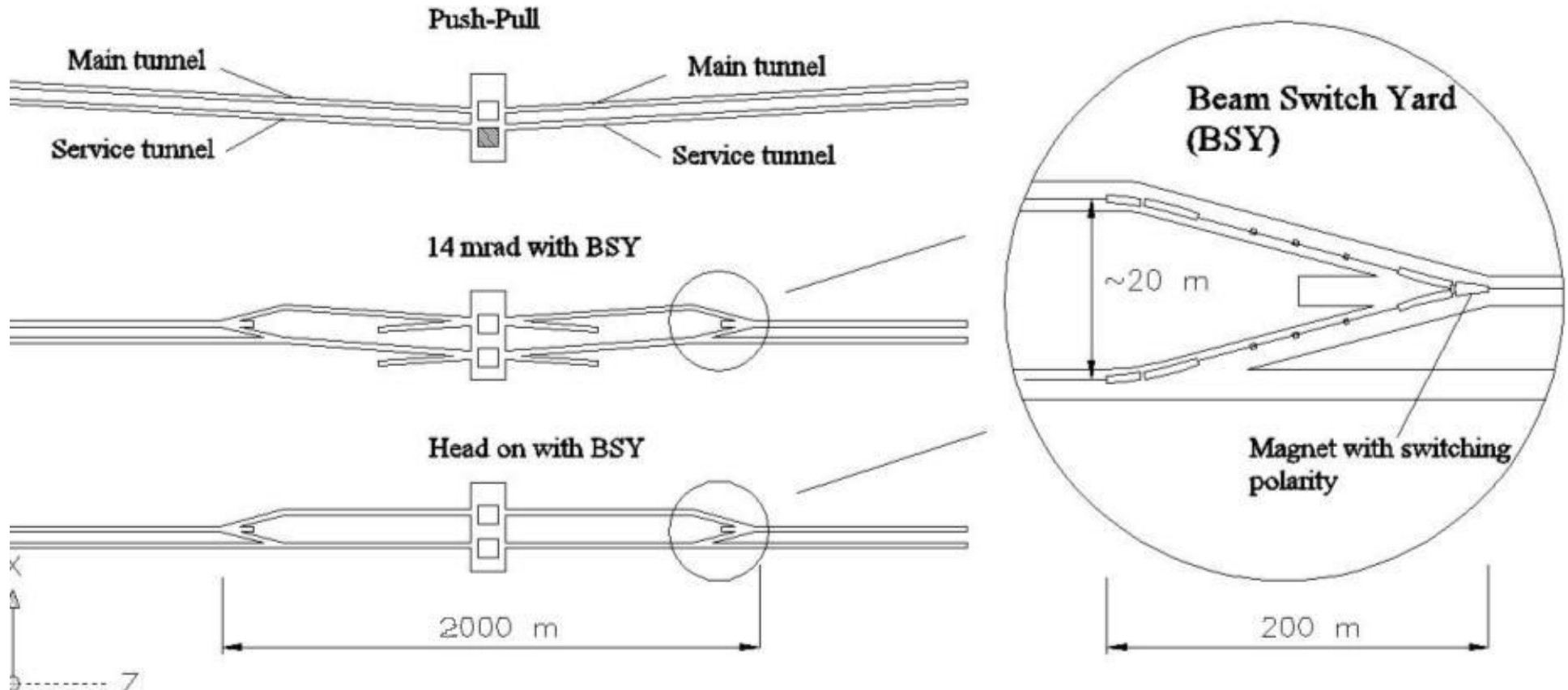

Scenario with Beam Switch Yard allows independent operation of detectors
Cost of additional optics is comparable with all push-pull complications
FF lenses are mostly expensive and every detector has these lenses already
4th CD can be easily fit into this scenario

CONCLUSIONS

4th-concept allows easy installation into cave as **it has no heavy iron**

Elements of FF optics mounted on detector frame allow easy protection against ground motion

4-th concept easily accommodates 14 mrad optics (and any others).

Measures against vibrations force to locate front end electronics in a separate hut installed on vibration-isolative footers.

Modular concept of 4-th detector allows easy exchange of different equipment, such as TPC, vertex detector, sections of calorimeter electronics, etc.

Detector could be manufactured at lowest cost

Head on collision scheme allows undoubted benefits for HEP and for the beam optics. Directional kicker with TEM wave is a key element of this scheme.

Beam Switch Yard solves many problems **if two detectors will be build at all**