

Permanent Magnets

Y. Iwashita
Kyoto University

PMQ with saturated iron pole

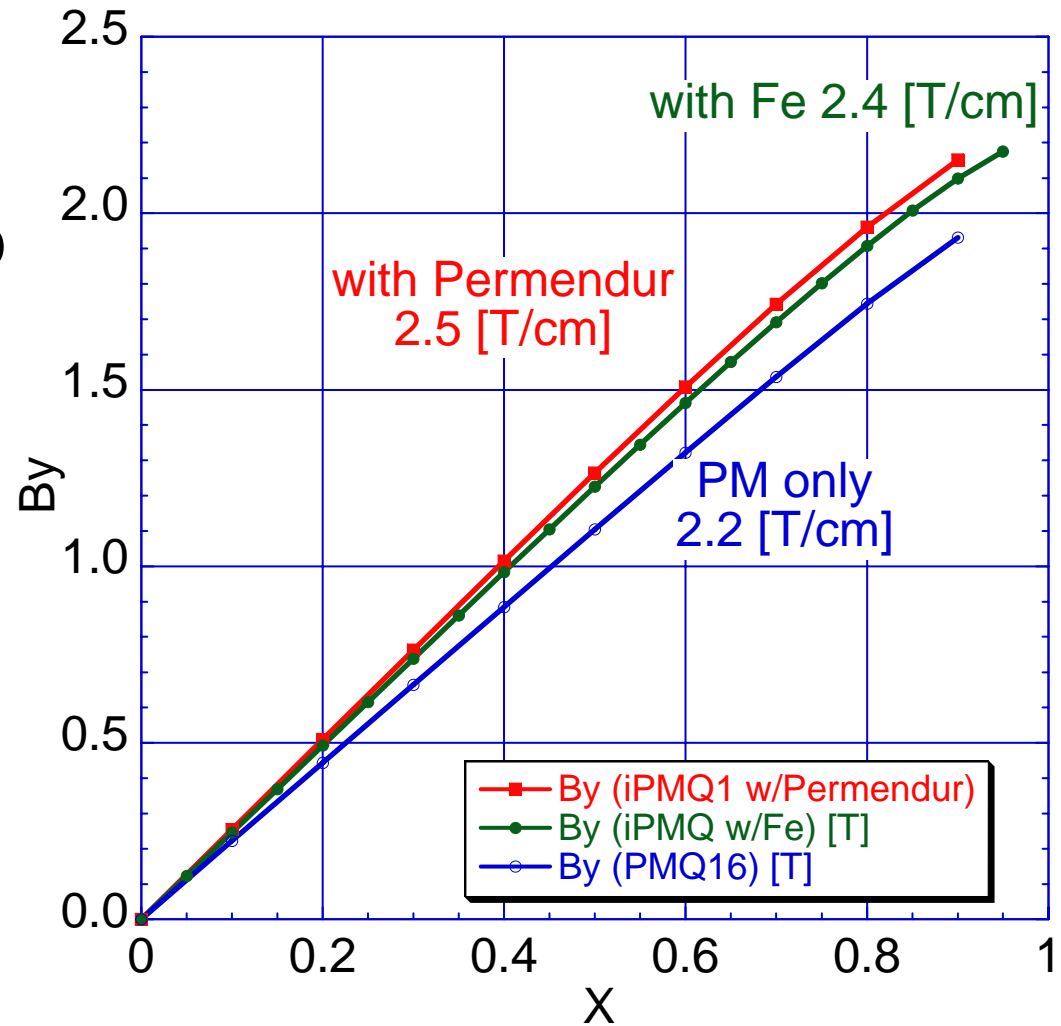
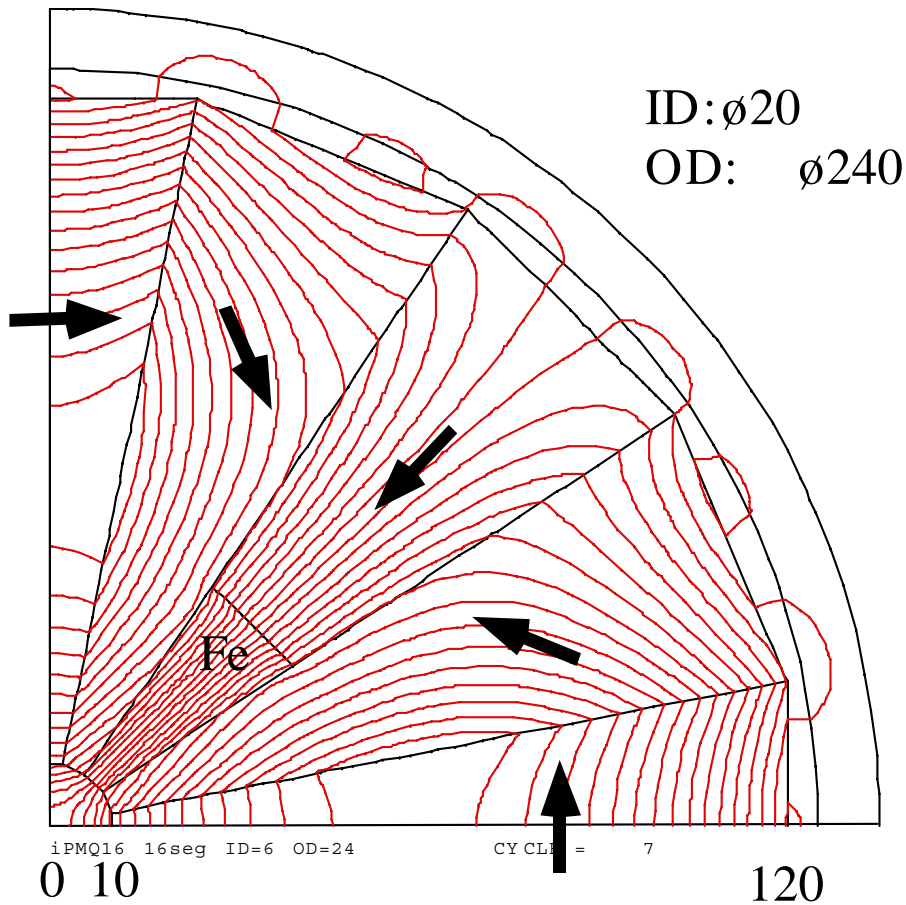

$$B = 2B_r (1 - r_1/r_2) \cos^2(\pi/M) \sin(2\pi/M) / (2\pi/M)$$

First prototype (fixed field)

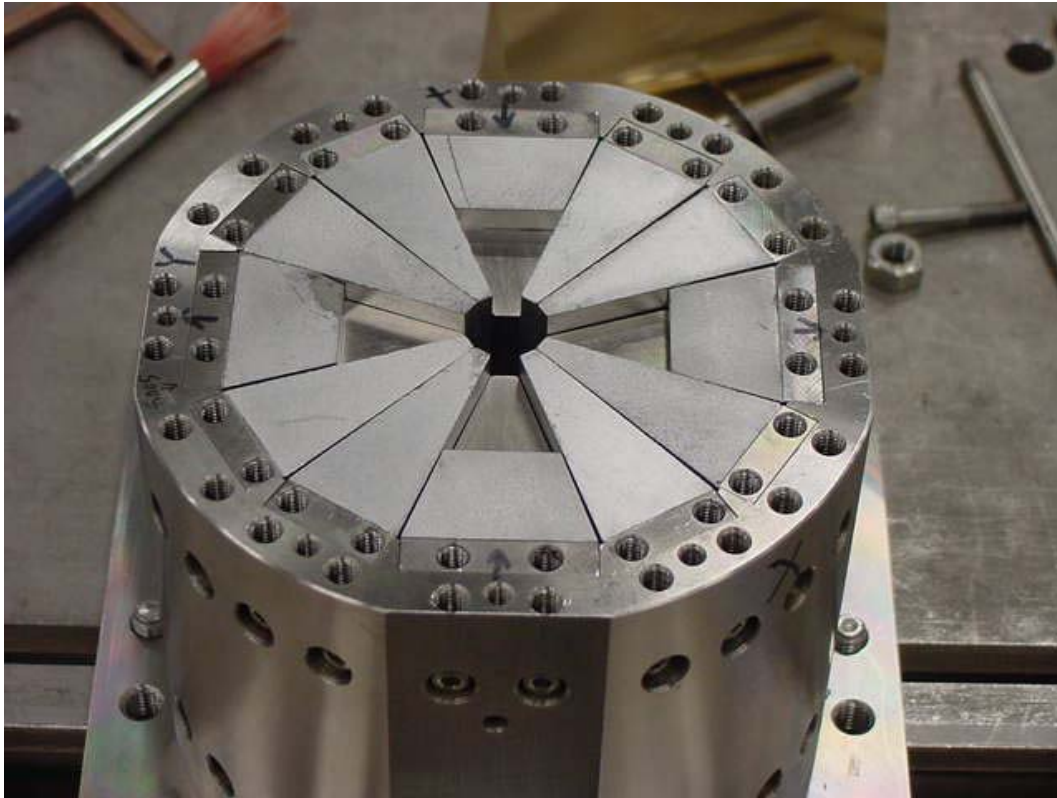

Prototype PMQ

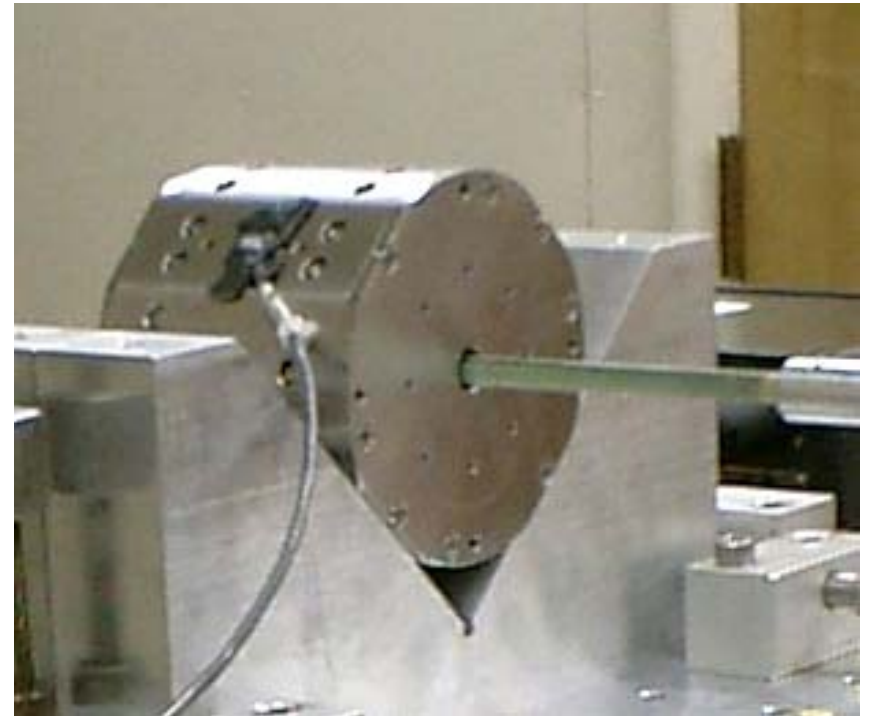

Measurement at SLAC

Double Ring Structure

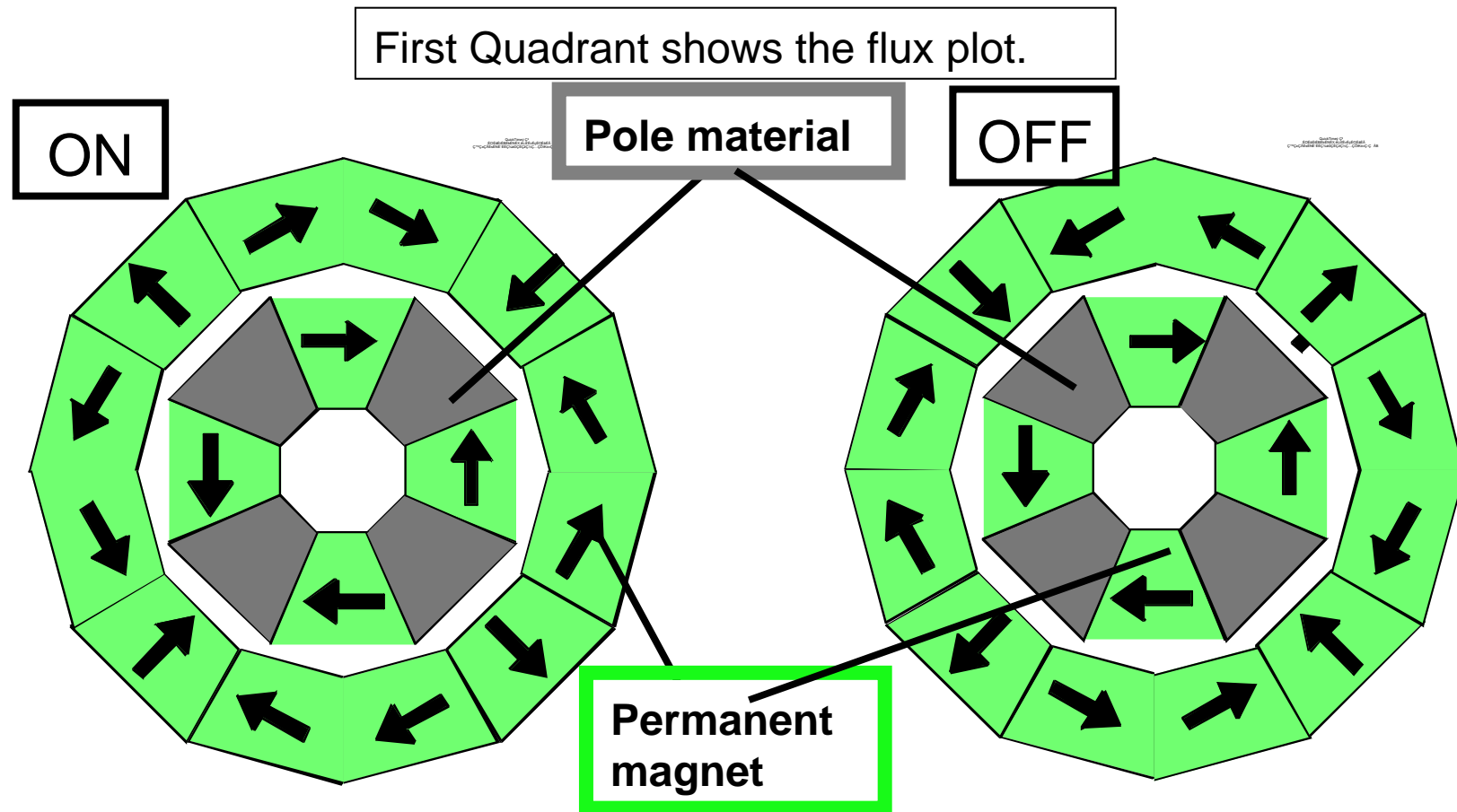

The double ring structure

PMQ is split into inner ring and outer ring. Only the outer ring is rotated 90° around the beam axis to vary the focal strength.

Adjustable Permanent Magnet Quadrupole

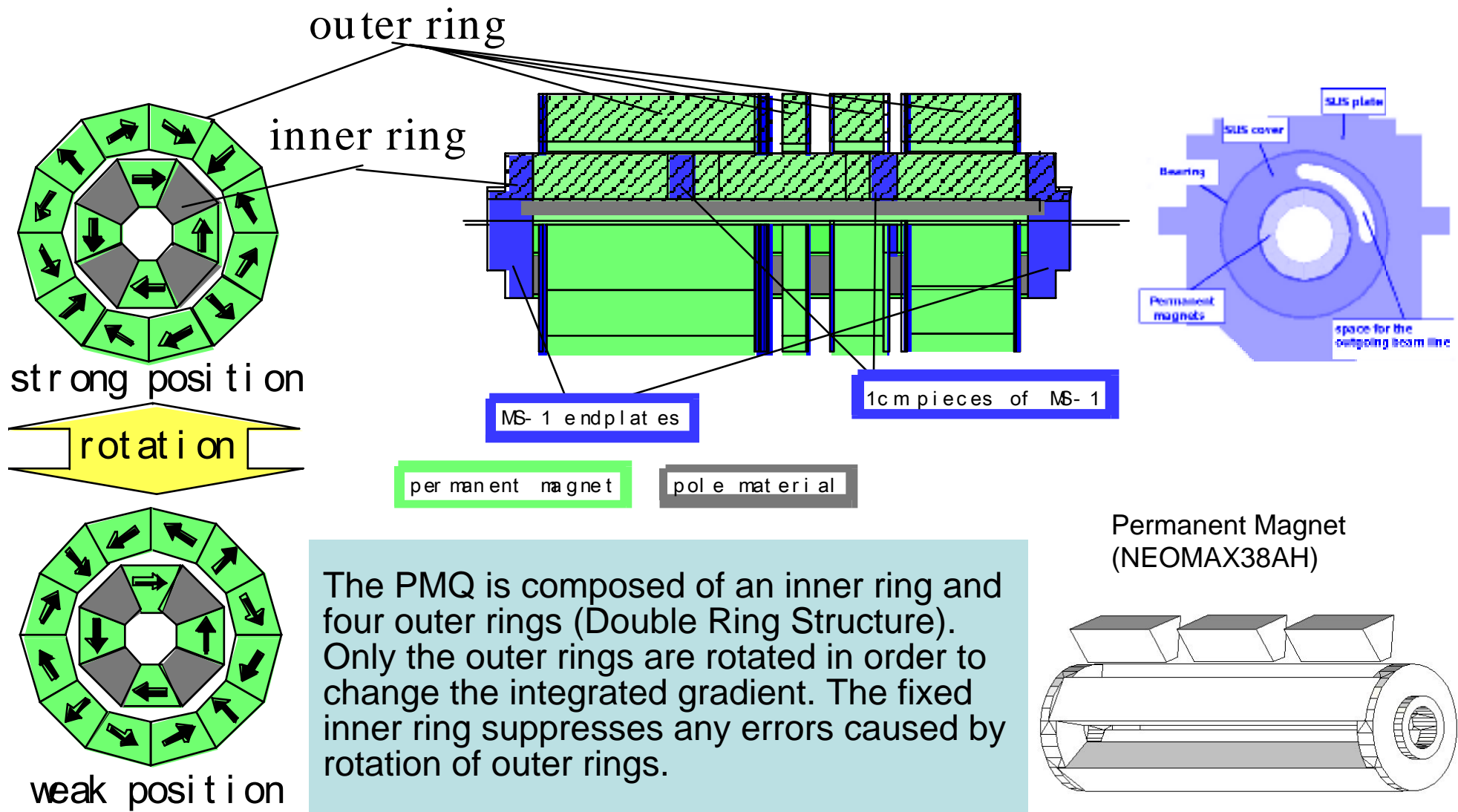

Drawing

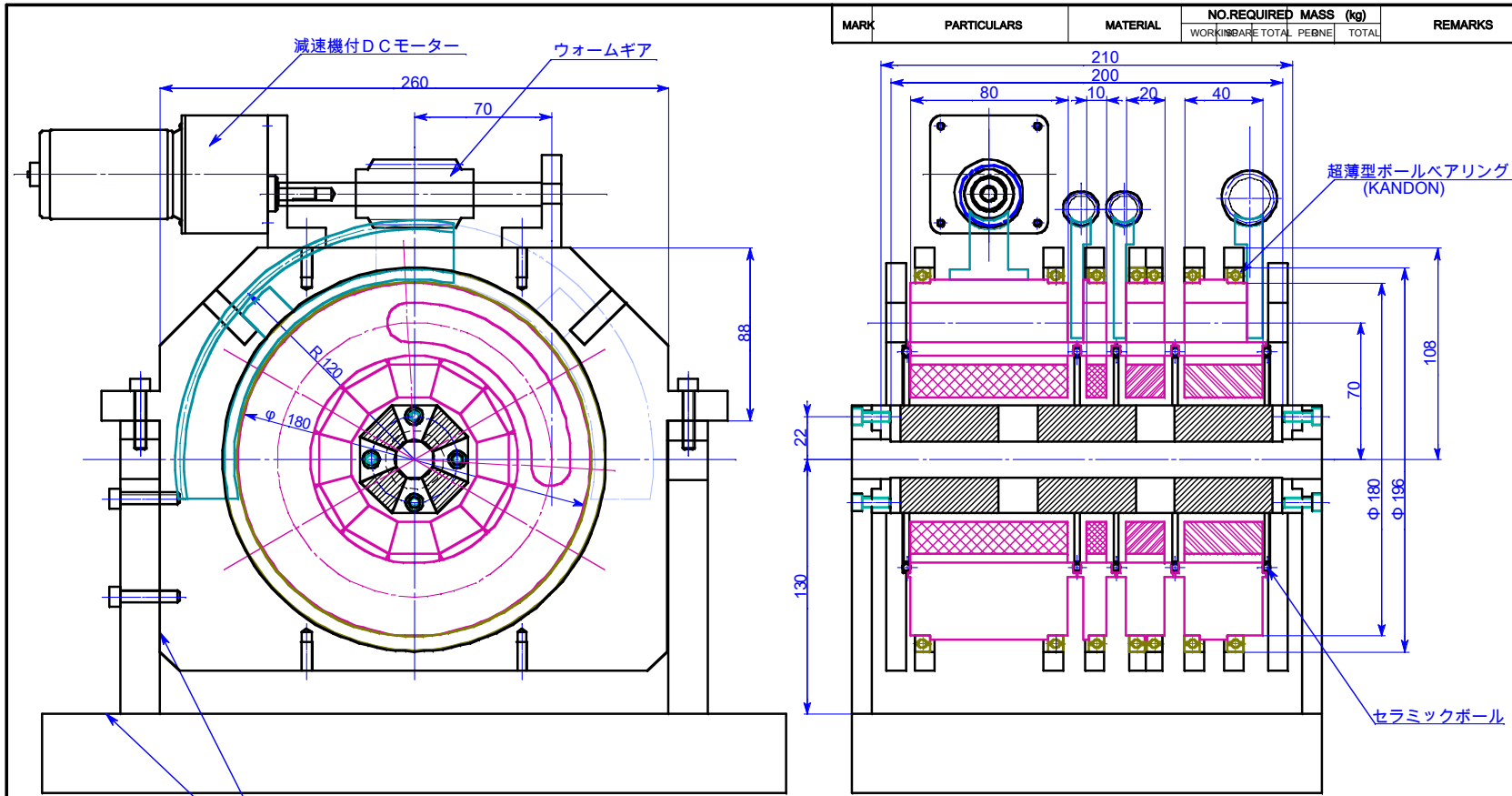

MARK	PARTICULARS	MATERIAL	NO. REQUIRED MASS (kg)		REMARKS
			WORK	INVENTORY	
			TOTAL	TOTAL	

2003/12/08	DATE	DESCRIPTION	MECHATRON	DESIGN	CHECK	APPROV
			Hisano			

SCALE	1:2	京都大学化学研究所殿向 2重Q-Magnet位置決め装置	DRAWN	DESIG.	CHECK	APPROV	配布先
PROJECTION	1ST ANGLE		分番	葉数			
PROJECTION	3RD ANGLE						
IHI 原子力事業部 高エネルギーシステム部		JOB NO.	MK03D		REV	1/2	控 1
		DRAWING NO.	G03				合計

Ishikawajima-Harima Heavy Industries Co., Ltd.

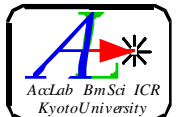

Prototype Magnet

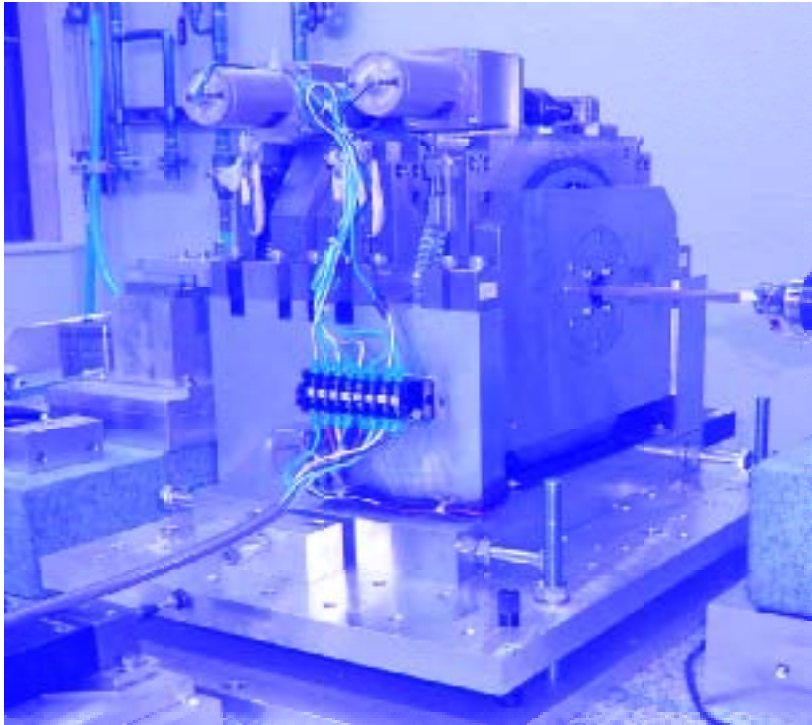

Bore radius	1cm
Inner ring radii	In 1cm out 3cm
Outer ring radii	In 3.3cm out 5cm
Outer ring section length	1cm, 2cm, 4cm, 8cm
Physical length	23cm
Pole material	Permendur
Magnet material (inner ring)	NEOMAX38AH
Magnet material (outer ring)	NEOMAX44H
Integrated gradient(strongest)	24.2T
Integrated gradient (weakest)	3.47T
Int. gradient step size	1.4T

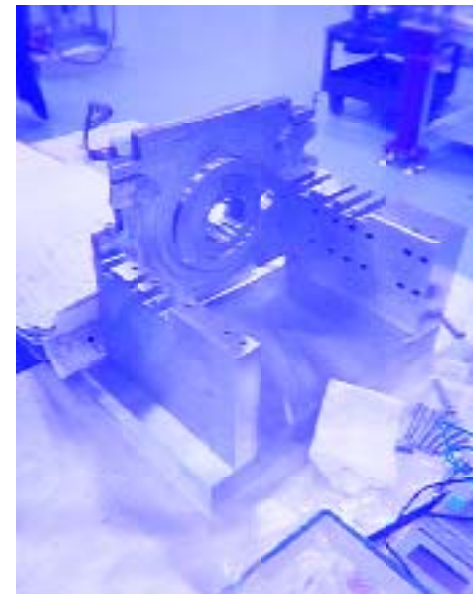

Making of the PMQ

Photos

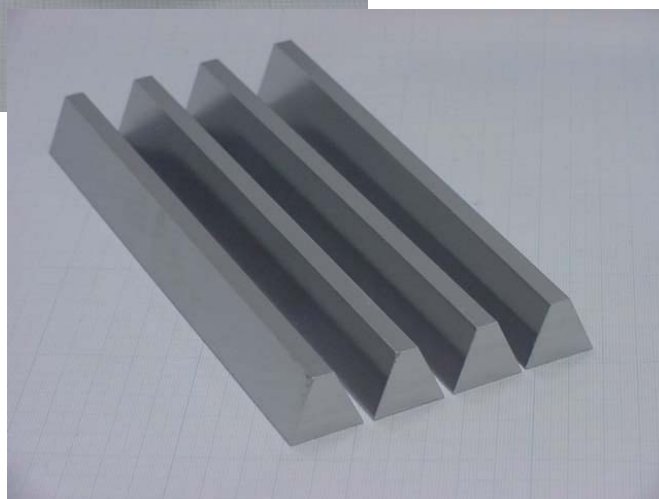

Magnetic Center Movement

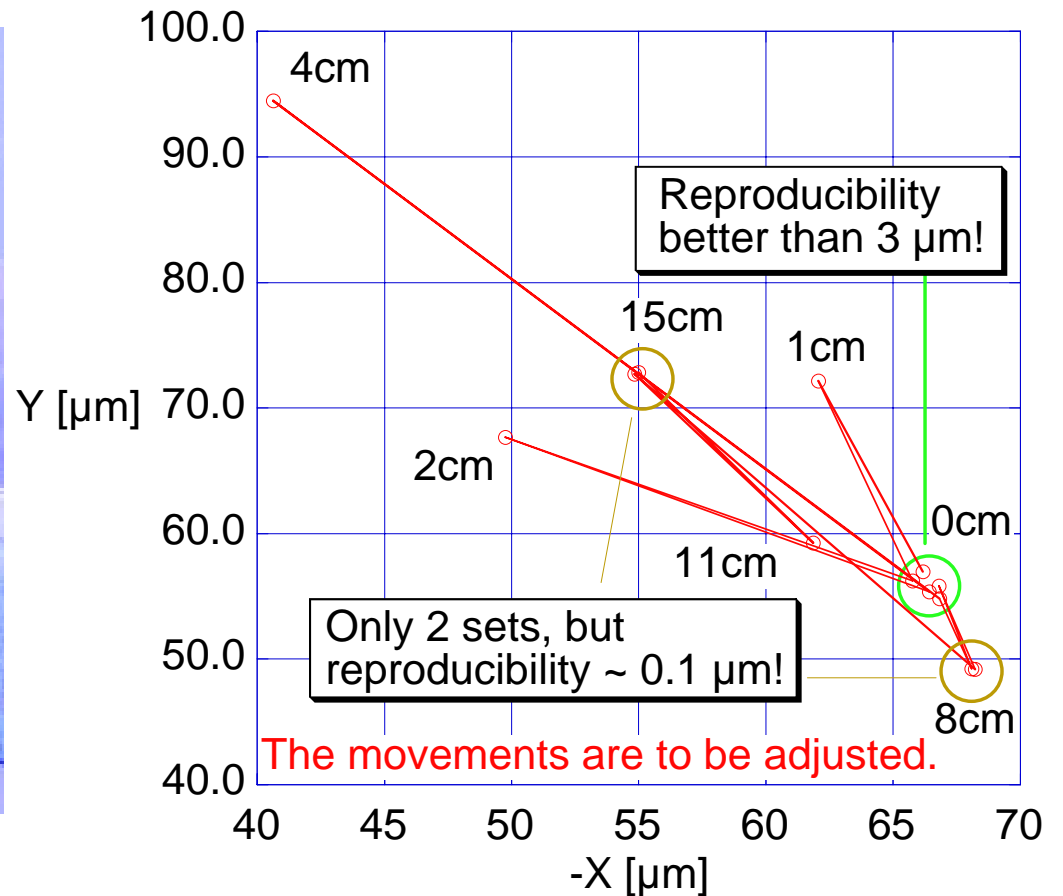
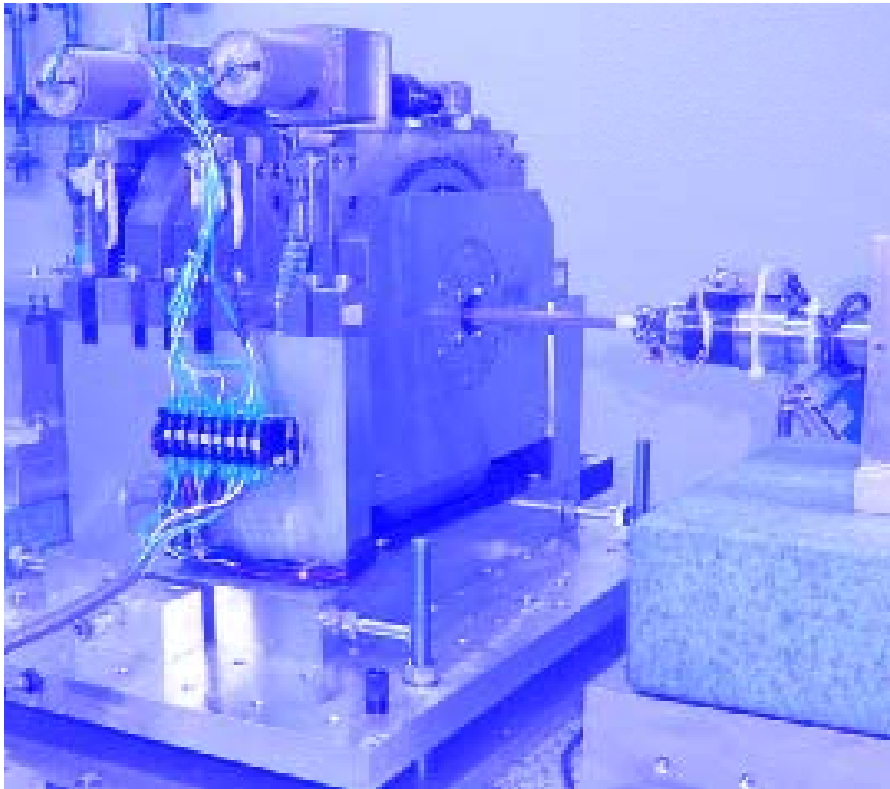

Magnetic Center moves by tens of micron when the strength was changed.

Configurations for Various Crossing Angles

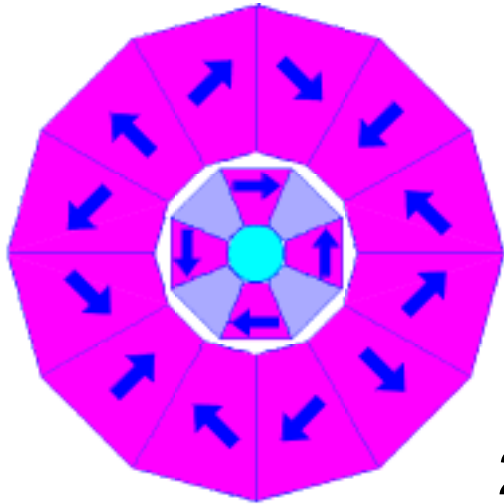

0 mrad.
(Head-On)

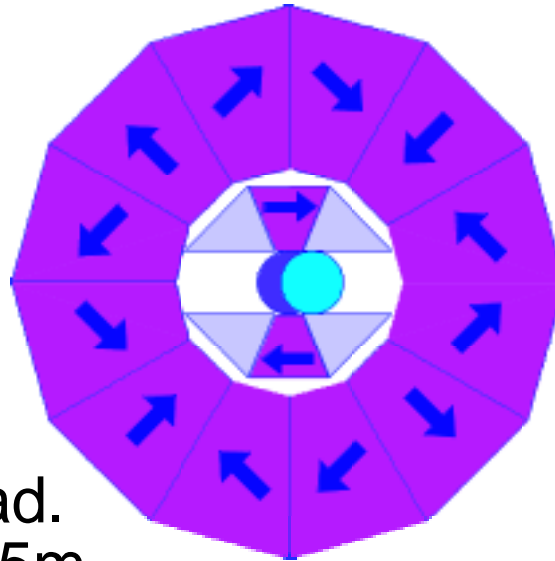

2 mrad.
 $L^*=3.5\text{m}$

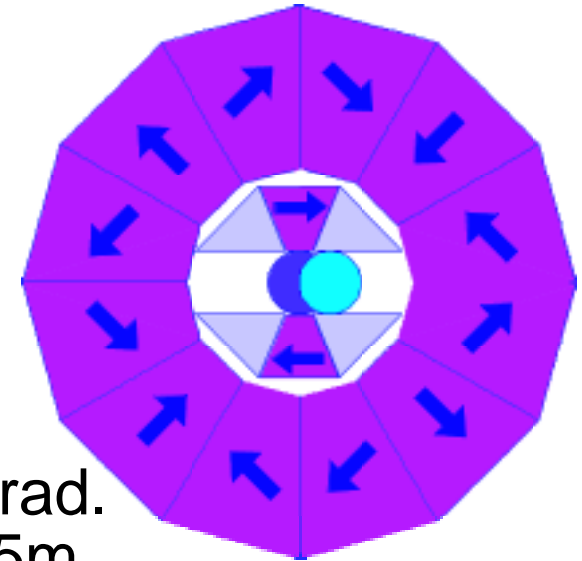

2 mrad.
 $L^*=5\text{m}$

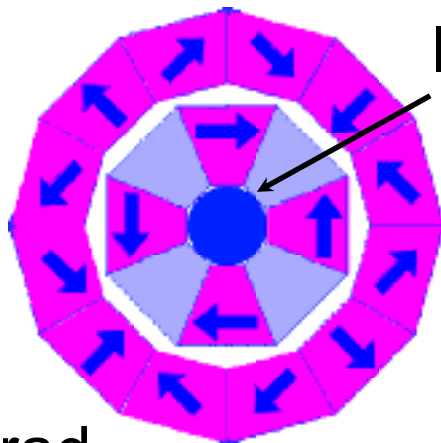

20 mrad.
 $L^*=3.5\text{m}$

Incoming Beam



Outgoing Beam

Table II PMQ parameters for various crossing angles.

Crossing angle [mrad]	0	2	20
Outer Diam. [mm]	180	180	100
Max. Gradient [T/m]	180	130	120
Min. Gradient [T/m]	-20	-60	8

Demagnetization by Radiation

Energy deposit

	GLD	SiD	SiD(by Takashi)	<u>neutron</u>
BeamCAL	17mW	13mW	29mW	
QD0	94mW	97mW	147mW	10^5 [n/cm ² s]]
SD0	11mW	11mW	11mW	
QF1	16mW	18mW	15mW	
SF1	0.4mW	0.3mW	1mW	

very preliminary results by T.Abe (university of Tokyo), in private communication

Demagnetization by 14MeV neutron

Magnet	Demag. ratio [/ 1×10^{13} n/cm ²]	iHc [Oe]
47H	10.2%	
44H	1.8%	16
39SH	0.7%	21
32EH	0.3%	30

T. Kawakubo, et al., The 14th Symposium on Accelerator Science and Technology, Tsukuba, Japan, November 2003, pp. 208-210, in Japanese, [http:// conference.kek.jp / sast03it / WebPDF / 1P027.pdf](http://conference.kek.jp/sast03it/WebPDF/1P027.pdf)

Continuous 1 mo. operation may cause about 0.01[%] of (reversible?) demagnetization on NEOMAX 32EH.

Effect of Solenoid

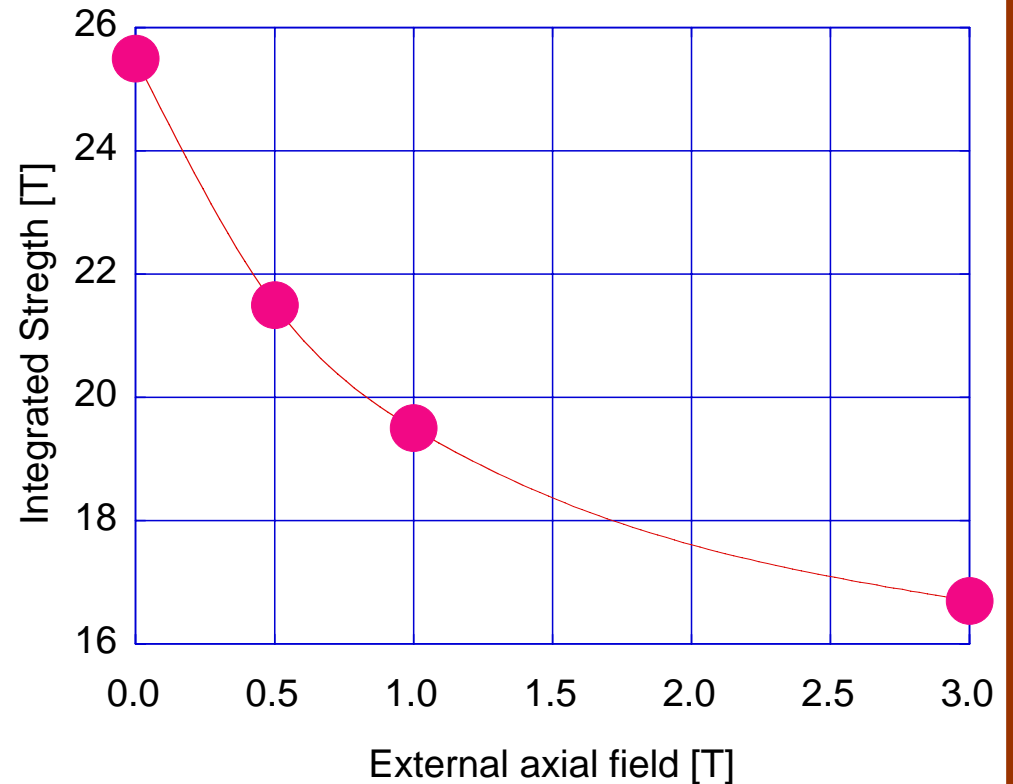
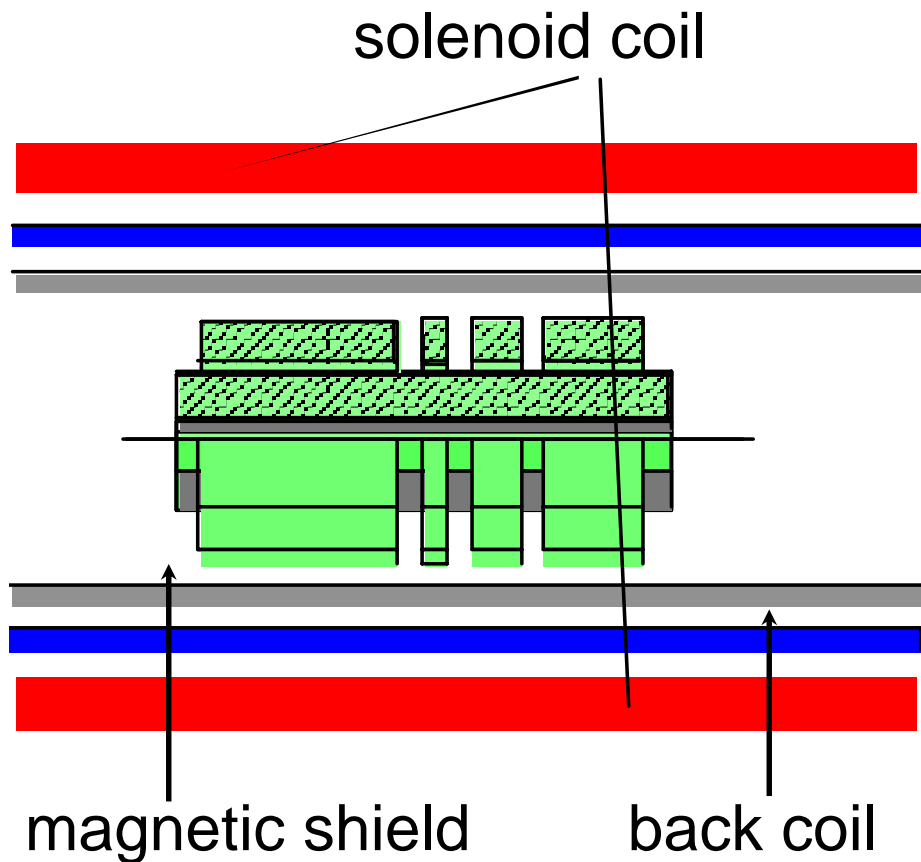

Integrated strength is reduced by Solenoid field because PMQ has pole (vanadium permendur). Back coil and/or some shield is needed.

Recent Modification

Demonstrate a higher field gradient by reducing the bore size from $\phi 20\text{mm}$ down to $\phi 15\text{mm}$.

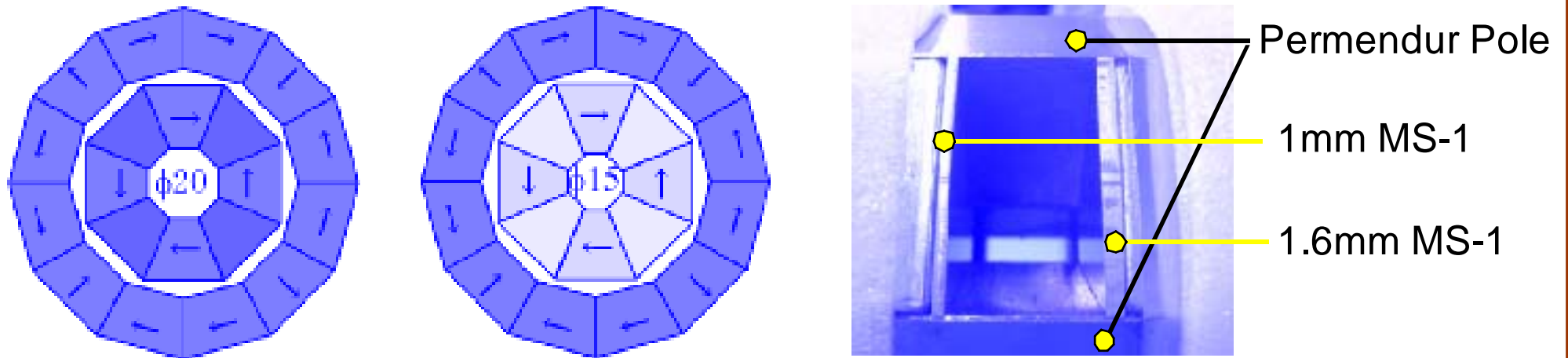

Temperature compensation of the inner ring; 1 mm (left) and 1.6 mm (right) MS-1 trapezoidal plates are seen in a 2cm space between magnets.

Longitudinal Distribution

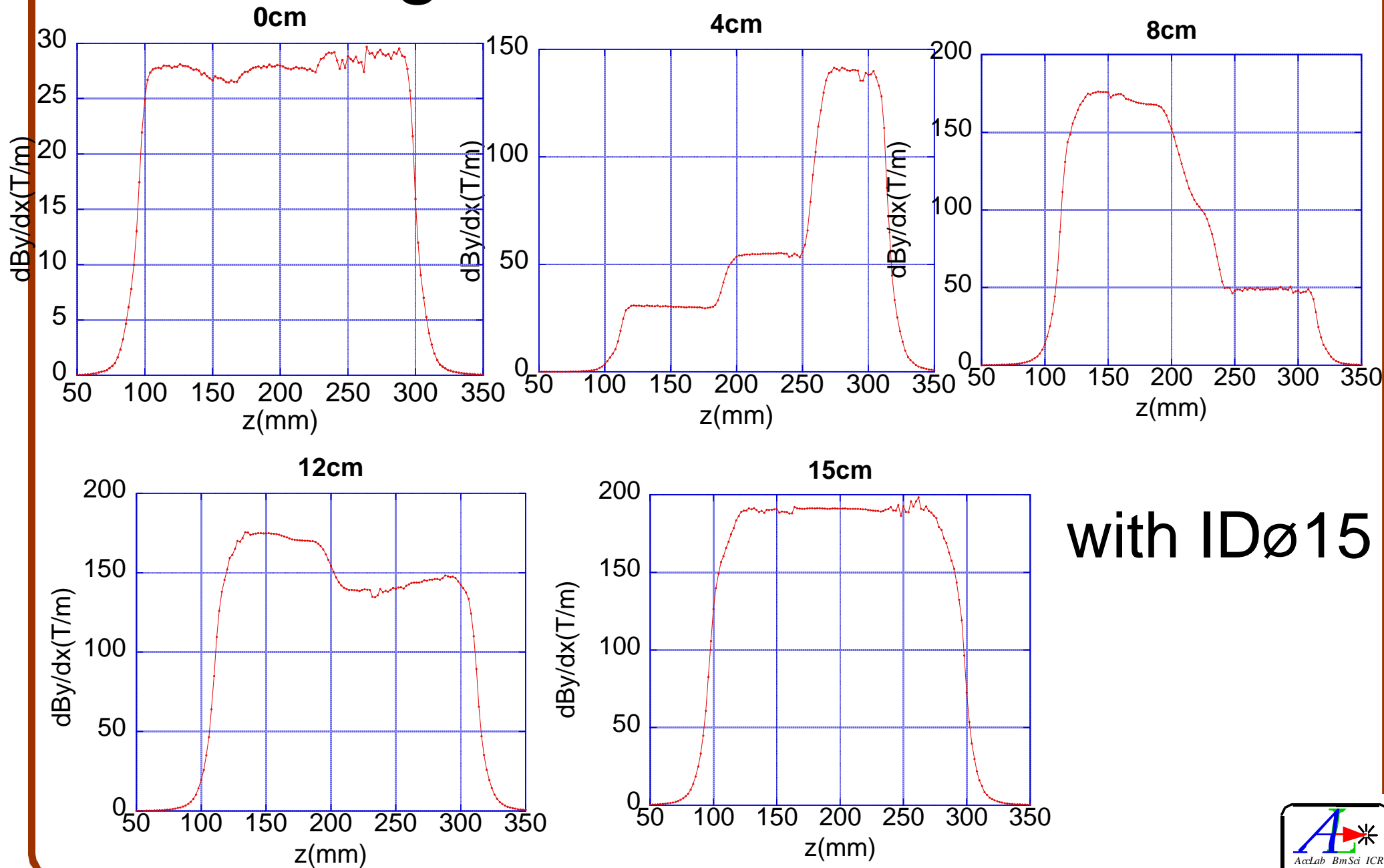

with ID \varnothing 15

Rotating Coil Stand

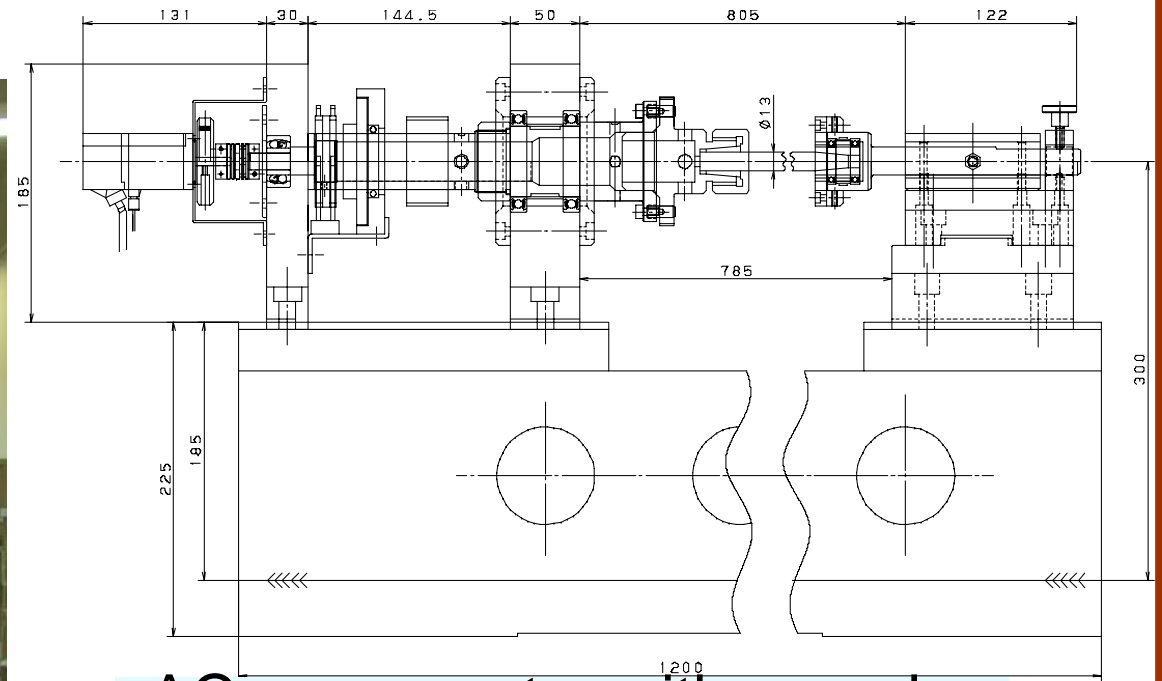

AC servo-motor with encoder
(up to 600 RPM)

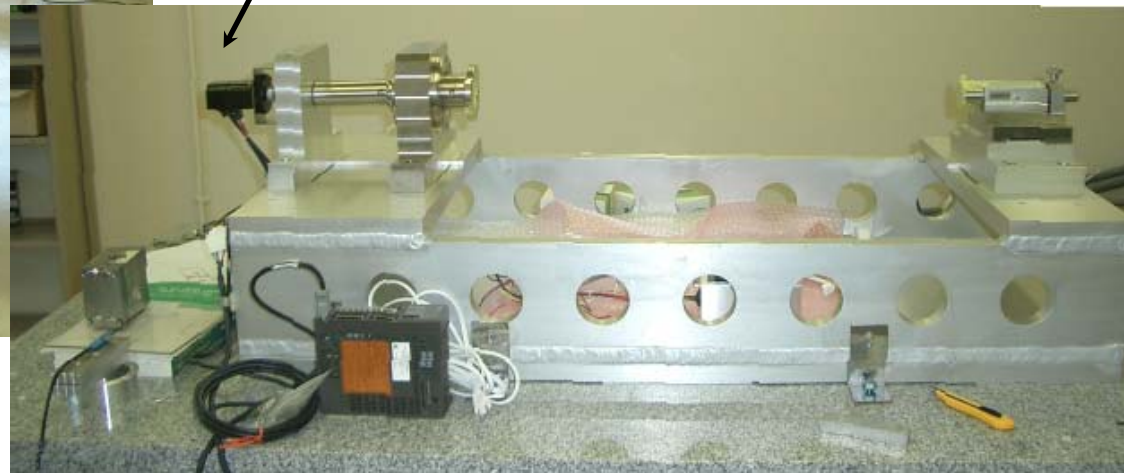

What's next?

- Finish magnetic field measurement system
- Fabricate third model
- Sextupole?
- Octpole?
- more?

Rotating PMSx for cold neutrons

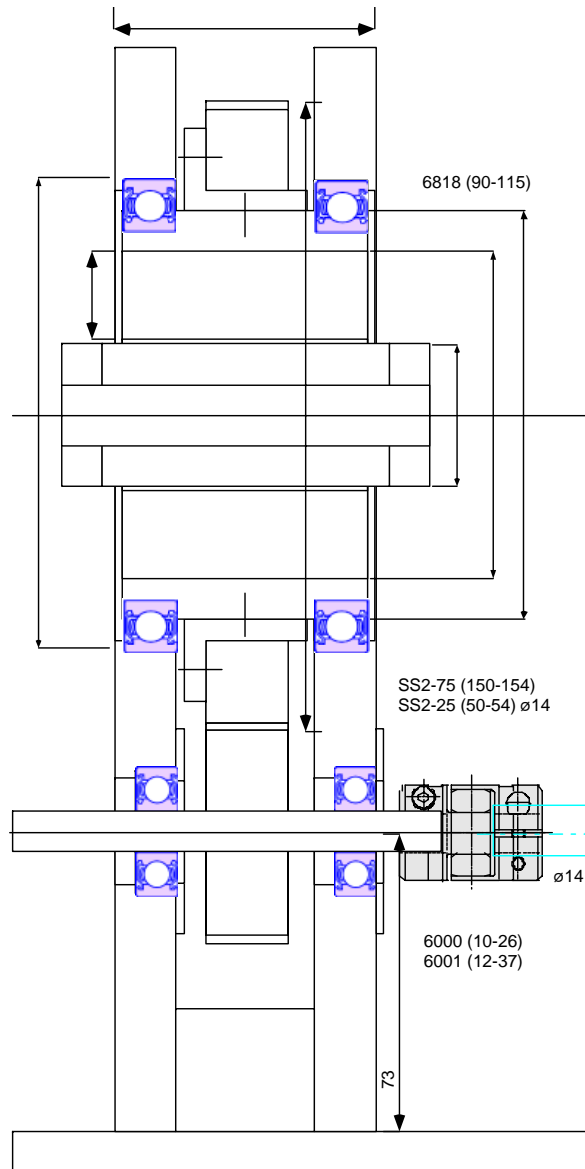

QuickTimeý Ç²
Sorenson Video êLíÊÉvÊçÉOÉâÉÄ
Ç™Ç±ÇÄÉsÉNÉ`ÉÉÇ¾â©ÇÉÇžÇ½Ç...ÇÖiKóvÇ-Ç ÅB

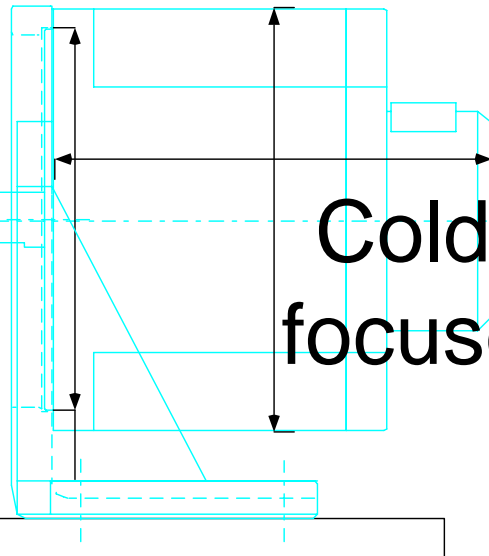

Cold neutron beam can be focused by strong sextupole. 25Hz for ToF.