



Dumps and Collimators Technical System Status

Tom Markiewicz/SLAC
Vancouver GDE/ALCPG Meeting
19 July 2006
representing S. Ban and C. Densham
with invaluable input from D. Walz & L. Keller

A horizontal line of small yellow dots is located at the bottom of the slide, mirroring the one at the top.



Status: Engineering

Parts list: ~Complete

- **Dumps (39)**
- **Fixed aperture collimation devices (95)**
- **Variable aperture collimation devices (115)**
- **MPS and PPS stoppers (28)**

Requirements: More work needed

- **Dumps**
 - Peak power for nominal parameters
 - Duty Factors for short (seconds) and long (year) periods guesstimated
- **Collimators**
 - Power load estimated by area leaders or WGs
 - High Lum parameters at 1 TeV used to determine technology choice

Basic Device Technology assigned based on incident power, beam energy and particle type

- **18MW-600kW: Pressurized water dump**
- **600kW-40kW: Metal balls in water bath**
- **40kW-25W Peripheral cooled solid metal**
- **25W – 0W Un-cooled metal**



Design & Interface Issues

Design parameters studied for 18MW dumps & guesstimated elsewhere

- **SLAC 2MW dump and two industrial studies done for TDR**
- **Examples of all other devices available at SLAC**

Local and remote shielding requirements guesstimated based on beam power and long period duty factor

CF&S

- **space specified for main dump enclosures**
- **space specified for underground rad-water pump/processing facilities for relevant device types**
- **LCW flow requirements based on rule of thumb (P, ΔT)**
- **No layout drawings made to understand constraints**

Other TS

- **incomplete list of devices requiring I&C**
- **incomplete list of supporting instrumentation (Ion chambers)**
- **no serious conversation/plan (yet) for installation/replacement**



Design Work Which Should be Done When Effort is Available

- Formal part breakdown structure for each device type
 - **i.e. better definition of devices (real design)**
- Regularize specifications when they exist
 - **18MW Dump specs from 3-5 May 2006 D&C Meeting @ SLAC**
 - **“Engineering” specs called out by area leaders**
 - Who assigns the performance and engineering overheads?
- Make sure handshake with areas and other TS/GS exists and is accurate
- Layout drawings made to understand relationship of beamlines, devices and tunnels
- Separate out site dependent aspects of design
- Calculations (EGS/FLUKA/SHIELD11/ANSYS) to validate and refine current design assumptions
- Rudimentary CAD or better cartoons



Missing Information

- Basic design concepts for photon devices
 - **Beamstrahlung dump for 2 mrad**
 - **Undulator photon dump**
 - **Undulator collimator**
- Better understanding of variation of device requirements with beam parameter variation and management decision of engineering design point
 - **currently assume “high lum” parameters and resultant beam loss**
- Beam spot size at each device (other than final dump)
- Names of group responsible for “Supports and Movers”
 - **ubiquitous throughout ILC; needed for adjustable collimators**



Cost Methodology

First Unit Costs:

- **2003 industrial est. for 18MW water dump plumbing**
- **1991 SLAC “bill” for sector 30 collimators**
- **Engineering estimates of D. Walz based on 40 years of actual construction/operation of similar devices**

Economy of scale factor for each device type

- **Learning curve not applied**
- **Minimum=60% for 72 H2O-cooled protection collimators**

ED&I baseline set to 25% and adjusted upward for difficult one-off devices

- **NOT estimated bottom’s up**

Best-Engineering estimates of Walz in 2006 \$

Cost-Dominant 18MW dump taken from 2003 German study & escalated

Average Unit costs distributed to areas on a per-item basis

Little effort made to verify that CF&S, I&C, Inst., Installation etc. costs for Dumps & Collimators have been captured



88% Total D&C Cost in 5 of 26 Device Types

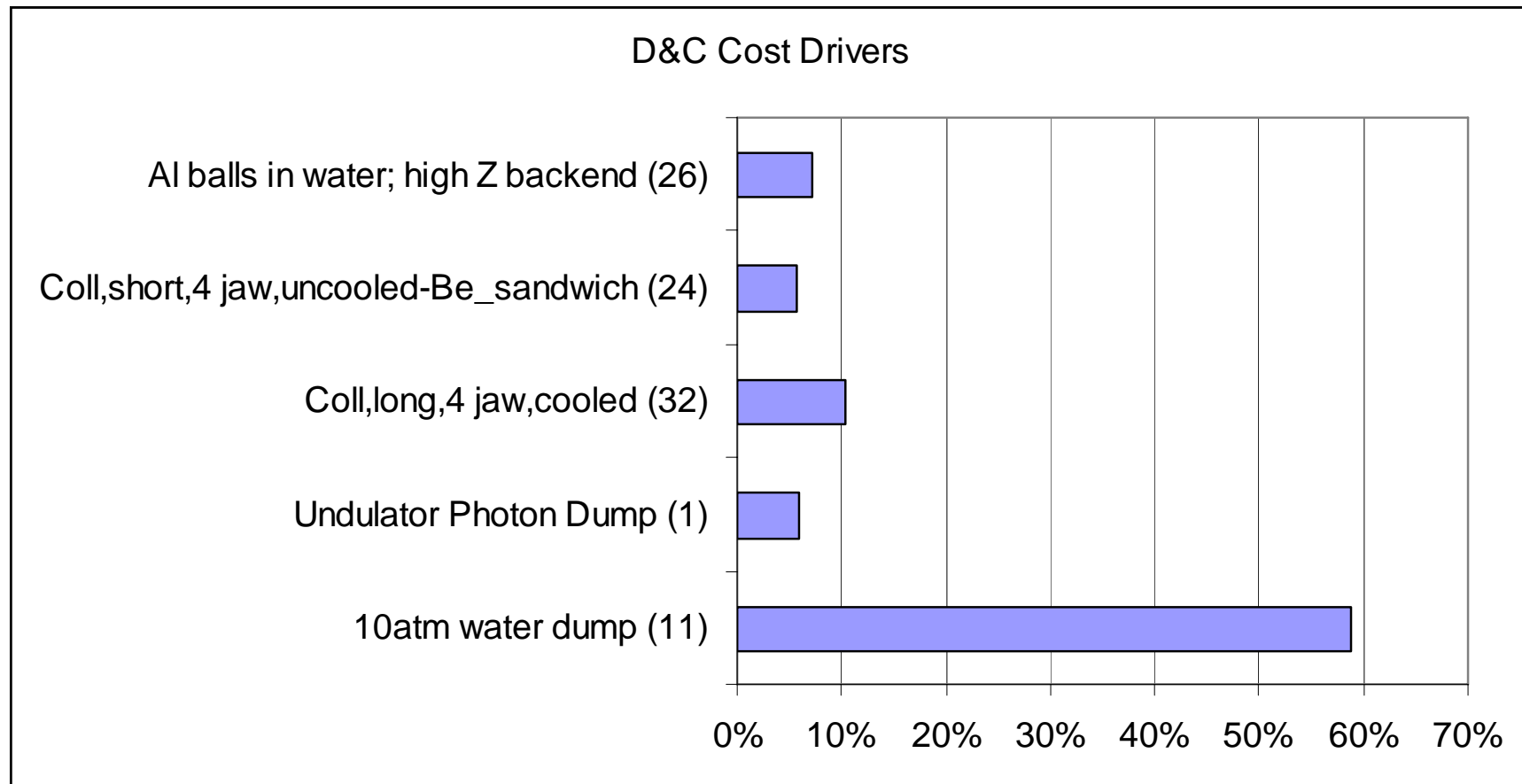



Cost Uncertainty

Two largest cost drivers have a basis of estimate

Walz vs. Industrial 18MW estimate differ by 50%

Most concerned that CF&S related costs will dominate total D&C related costs

- **will be given attention asap**

Largest cost risks:

- **items falling through cracks**
 - installation/replacement model
- **implications from technical risk of difficult devices we have not begun to consider**
 - e.g. photon dumps

No real effort yet to estimate accurately ED&I, economies of scale or required site resources



Possibilities for Cost Reductions

Component-level cost reduction

- **Studies of shielding requirements may reduce guessed-at values**
- **Studies of maximum and average power on collimators may result in reclassification and savings**
- **RTML 660kW dumps borderline and assigned as 10atm H₂O**
 - can move to lower class if study shows it is safe or rate/charge, etc. lower power

Design-level cost reduction

- **High Lum parameter set leads to many 250kW water-cooled-ball collimators**
- **2mrad has 250kW water-cooled-sphere adjustable collimators**
- **Full consideration of Himel list of reduced parameter operation**



Plans and Goals

Plans and goals for this workshop

- **Low expectations given the extreme parallelism of workshop and dearth of people working in the area**
- **Meeting with BDS planned during BDS parallel**
- **Meeting with I&C planned during D&C parallel**
- **Personally available to work/talk to anyone else during the Dumps & Collimator parallel session**

Plans for period between this and the Valencia workshop

- To-Do list outlined earlier will easily saturate all resources
- No devoted resources have been allocated to this task. It is being done on a best-efforts basis by people whose arms have been twisted.



TDR Report Phase

Experienced engineers to do bottoms-up design

- **Manpower requested from US manager in current US FY'07 budget discussion**

R&D on dump window and other technologies

- **Personnel for studies & R&D explicitly requested in recent UK LCABD budget request**



Bonus Slides Follow





Interfaces and Communications Recorded on Wiki

ILC International Linear Collider

rdr:rdr_ts:collimators_dumps ILC WIKI

Edit this page Old revisions Recent changes Search

Trace: > collimators_dumps

Collimators and Dumps

Charge [Edit](#)

Responsible for protection spoilers, beam dumps, PPS and MPS protection dumps, and beam collimators.
(from [Charges for RDR Leaders](#) (January 12, 2006))

Schedule [Edit](#)

2006
July 19-24 - Vancouver meeting; next round of estimates due
June 25 - Sunday - First Cost Estimates Due to DCB (for Vancouver Meeting)
June 19 - Monday 1300 GMT - Tech System Status (w/ Installation)
May 3-5 - Wed-Fri: Collimation and Beam Dump Meeting at SLAC

People [Edit](#)

Group leaders are [Shuichi Ban](#), [Chris Densham](#), and [Tom Markiewicz](#). You can email all of us by clicking [here](#). The official contact person has not yet been specified.

Group Members also include [Rob Appleby](#), [Roger Bennett](#), [Wilhelm Bialowons](#), [Eric Doyle](#), [Juan Fernandez](#), [Lew Keller](#), [Micheal Schmitz](#), [Dieter Walz](#) and [Nigel Watson](#). You can email all of us by clicking [here](#).

Area Group Contacts

Electron Source [Axel Brachmann](#)
Positron Source [John Sheppard](#)
Damping Rings [Mike Zisman](#)
RTML [Peter Tenenbaum \(PT\)](#)

Table of Contents

- Collimators and Dumps
- Charge
- Schedule
- People
- Links to Areas & Systems
- Content

Installation [Fred Asiri](#)

Technical System Contacts

Vacuum Systems [John Noonan](#)
Accelerator Physics [Daniel Schulte](#) and [Kyoshi Kubo](#)
Instrumentation [Marc Ross](#)
Magnet systems **contact not required**
Cryomodules & Cavities **contact not required**
RF Power **contact not required**

[Edit](#)

Links to Areas & Systems

Electron Source

- [Schematic showing Dump Locations](#)
- [Beam Power& Dump Requirements](#)

Positron Source

- [Positron Source RDR Web Page](#)
- [Beam Power& Dump Requirements](#)(rev2;2006-06-08)
- [Collimator & PPS Stoppers](#) (rev3;2006-06-07)

[RTML](#)

BDS

- [Tape Files and Excel Parts lists for the six beamlines of the BDS](#)
- [ILC 2006b BDS Beamline Layout](#)

OPERATIONS

Dumps and Shielding walls memo - T. Himel 17Mar06

[Edit](#)

Content

Himel List of Dumps Tuned for cost savings

From 17Mar06 note
07June06 Memo

Comprehensive List of Dumps and Collimators

2006-06-09 Version
2006-06-08 Version

[Edit](#)

http://www.linearcollider.org/wiki/doku.php?id=rdr:rdr_ts:collimators_dumps



Electron Source D&C

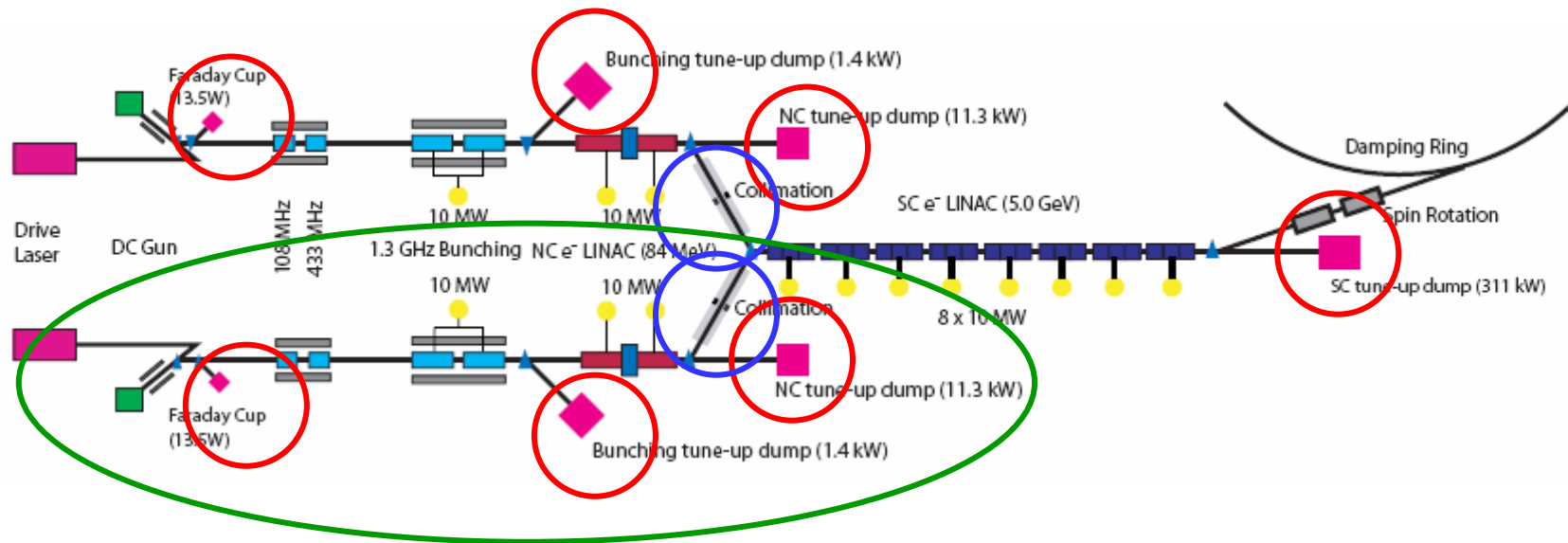



Positron Source D&C

ILC Positron System Beamlines

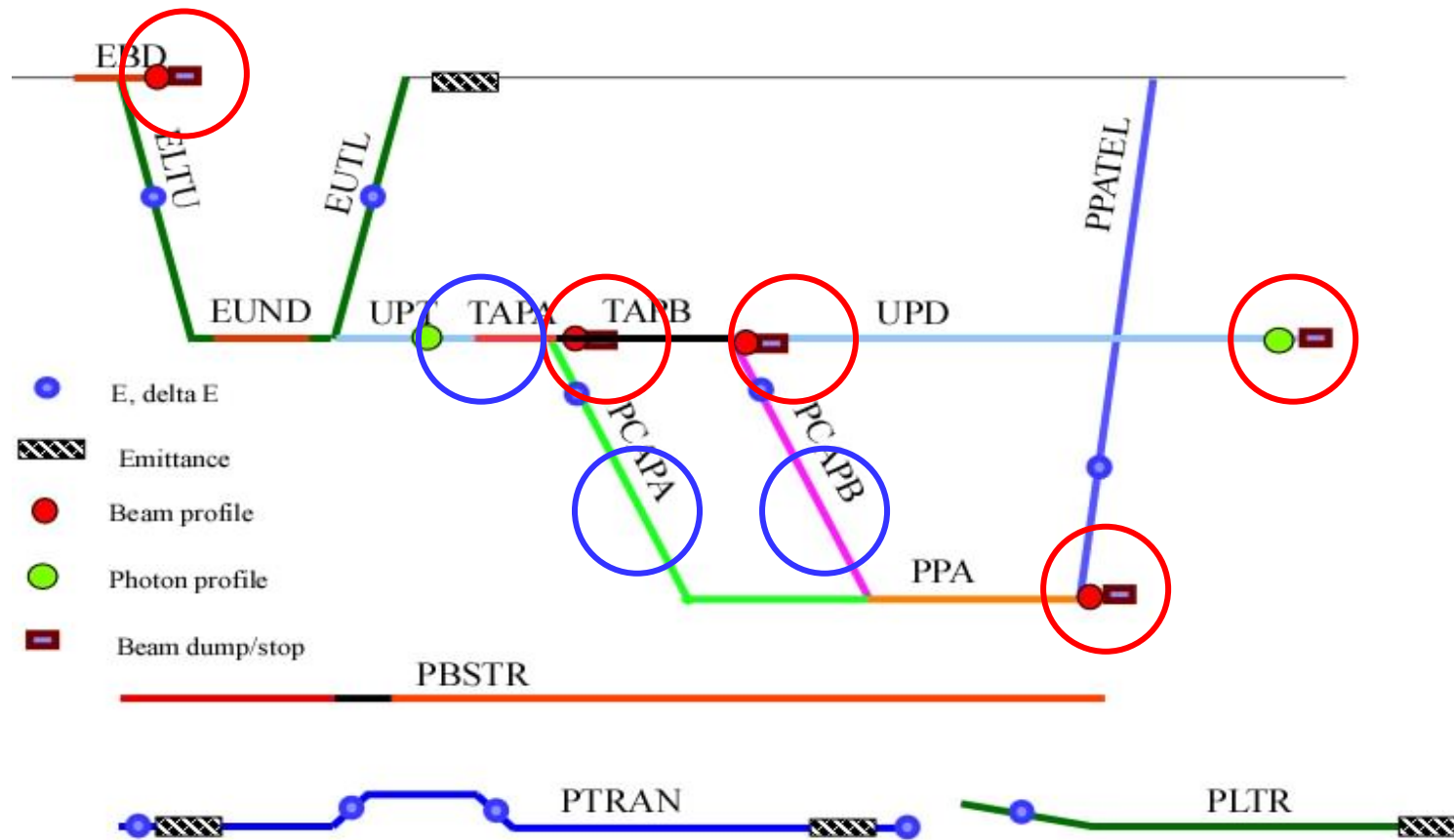



ILC Keep Alive Source, Rev 0.

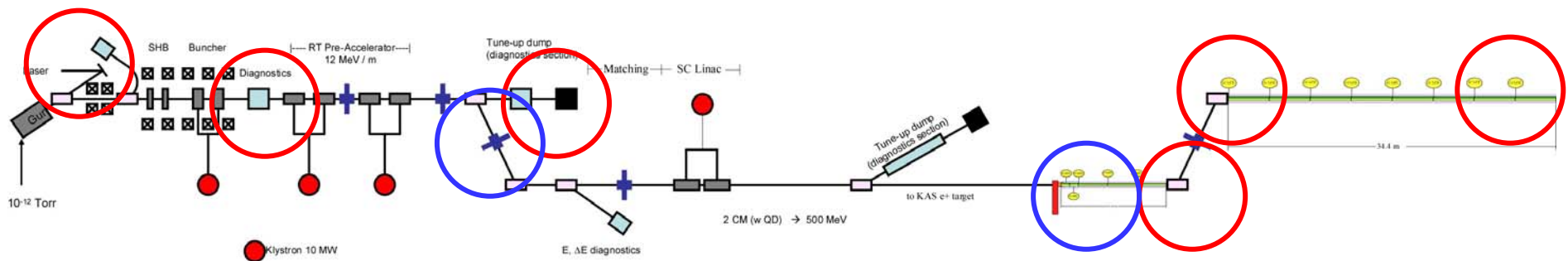



Assignment of Dump Type

Eng_Name	N	Locations	Technology	Enclosure (m ³)	RW/LCW (GPM for ΔT=30°C)
Dump:Normal:Charged:500GeV:18MW	4	End of Dump Lines	10atm water dump	21x11x18	2286
Dump:TuneUp:Charged:500GeV:18MW	2	End of Linacs	10atm water dump	??	2286
Dump:TuneUp:Charged:150GeV:6.8MW	1	Before electron bypass to positron production chicane	10atm water dump	??	857
Dump:Normal:Photon:500GeV:3.2MW	2	After 2 mrad IP	10atm water dump	??	405
Dump:TuneUp:Charged:15GeV:660kW	2	After BC2 in RTML	10atm water dump	??	86
Dump:Normal:Photon:40MeV:300kW	1	After positron production targets	Special dump with very special window: Low Z absorber with lots and lots of water; treat as water cooled aluminum ball dump from point of view of shielding and pumps	??	36
Dump:TuneUp:Charged:5GeV:225kW	2	Pre-DR tuneup dumps	Water cooled aluminum balls	??	29
Dump:TuneUP:Charged:400MeV:45kW	1	After NC positron acceleration to 400 MeV and before injection into positron transfer line and acceleration to 5 GeV	Solid aluminum block with peripheral cooling	??	6
Dump:TuneUp:Charged:5GeV:22kW	2	After BC1 in RTML	Solid copper block with peripheral cooling	??	3
Dump:Normal:Charged:114MeV:13kW	2	After the positron production targets	Solid aluminum block with peripheral cooling	??	2
Dump:TuneUP:Charged:400MeV:9kW	1	After NC positron acceleration to 400 MeV in low intensity KAS and before injection into positron transfer line and acceleration to 5 GeV	Solid aluminum block with peripheral cooling	??	1
Dump:TuneUp:Charged:100MeV:9kW	3	After NC L-Band structures for each of 3 electron gun line	Solid aluminum block with peripheral cooling	??	1
Insertable_TuneUP_Stopper:500GeV:8kW	4	In front of each IP	Insertable W-Cu-W sandwich peripherally cooled	??	1
Dump:Backup:Charged:114MeV:3kW	1	After the keep-alive-source positron production target	Solid aluminum block with peripheral cooling	??	0
Insertable_TuneUP_Stopper:5GeV:1kW	2	Between DR and RTML, in DRX; same as Himel called out (at higher power) for DR tuning running while downstream access/repair is permitted	Insertable Solid copper block with peripheral cooling	??	0
Dump:TuneUp:Charged:12MeV:1kW	3	After each electron sub-harmonic buncher	Solid copper block with peripheral cooling	??	0
Dump:TuneUp:Charged:120keV:10W	3	After each electron gun	Faraday cup	??	0
Dump:Abort:Charged:5GeV:45kJ	3	At each of the damping rings	Uncooled Al, Cu or Fe block	??	0
Dump:Abort:Charged:250GeV:2.3MJ	40	Uniformly spaced along each linac	Uncooled Al, Cu or Fe block	??	0



Rad Water & Shielding Requirements for each Type of Dump

Technology	Total	RW Pump House (m ³)	LS(Fe) (cm)	LS(B-con)) (cm)	RS(Con) (cm)
10atm water dump	11	15x12x4	50	150	200
Special dump with very special window: Low Z absorber with lots and lots of water; treat as water cooled aluminum ball dump from point of view of shielding and pumps	1	15x12x4	50	150	200
Water cooled aluminum balls	2	15x12x4	10	40	200
Solid aluminum block with peripheral cooling	8	No	10	40	200
Solid copper block with peripheral cooling	5	No	10	40	0
Insertable W-Cu-W sandwich peripherally cooled	4	No	10	40	0
Insertable Solid copper block with peripheral cooling	2	No	10	40	0
Faraday cup	3	No	0	0	0
Uncooled Al, Cu or Fe block	43	No	?	?	?
Grand Total	79				



10 bar H₂O Dump

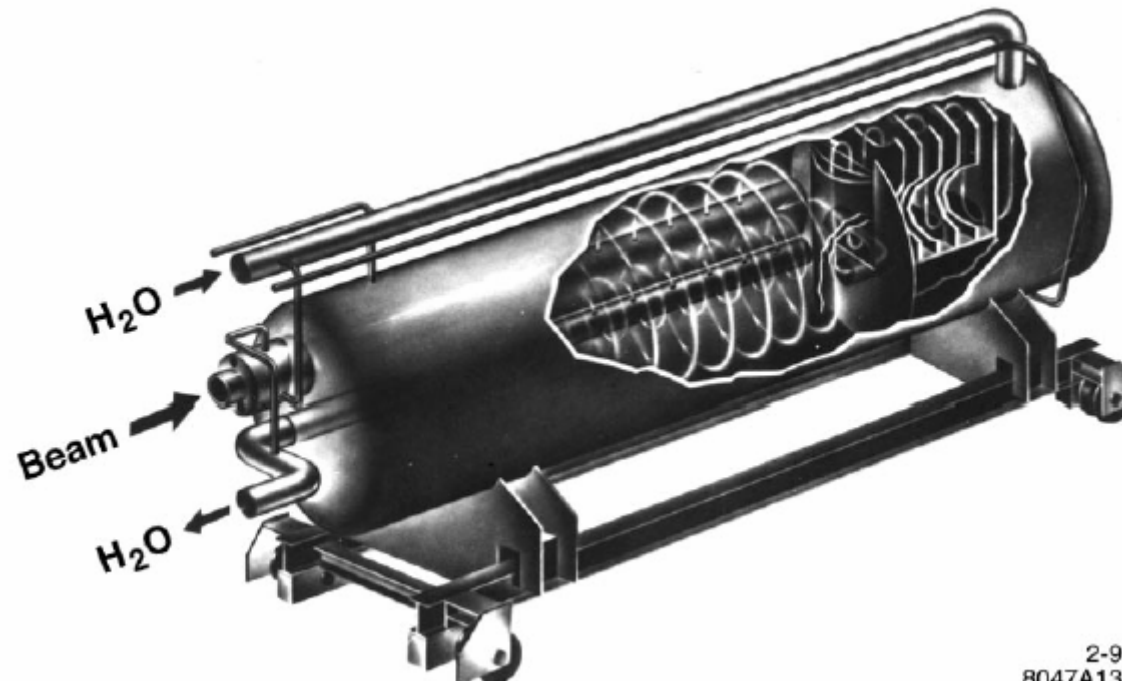

2-96
8047A132

- R=30cm where beam hits water flow
- Velocity(water) = 1-1.5 m/s
- Pressure water 10 atm so that T(boiling) ~ 180 °C
- Diameter vessel ~ 1.5m
- Length water ~ 6.5m (18 X₀)
- ~ 1m high Z to absorb remainder of shower after water section
- 30cm diameter 1mm thick Cu window



10 bar H₂O Dump Plumbing

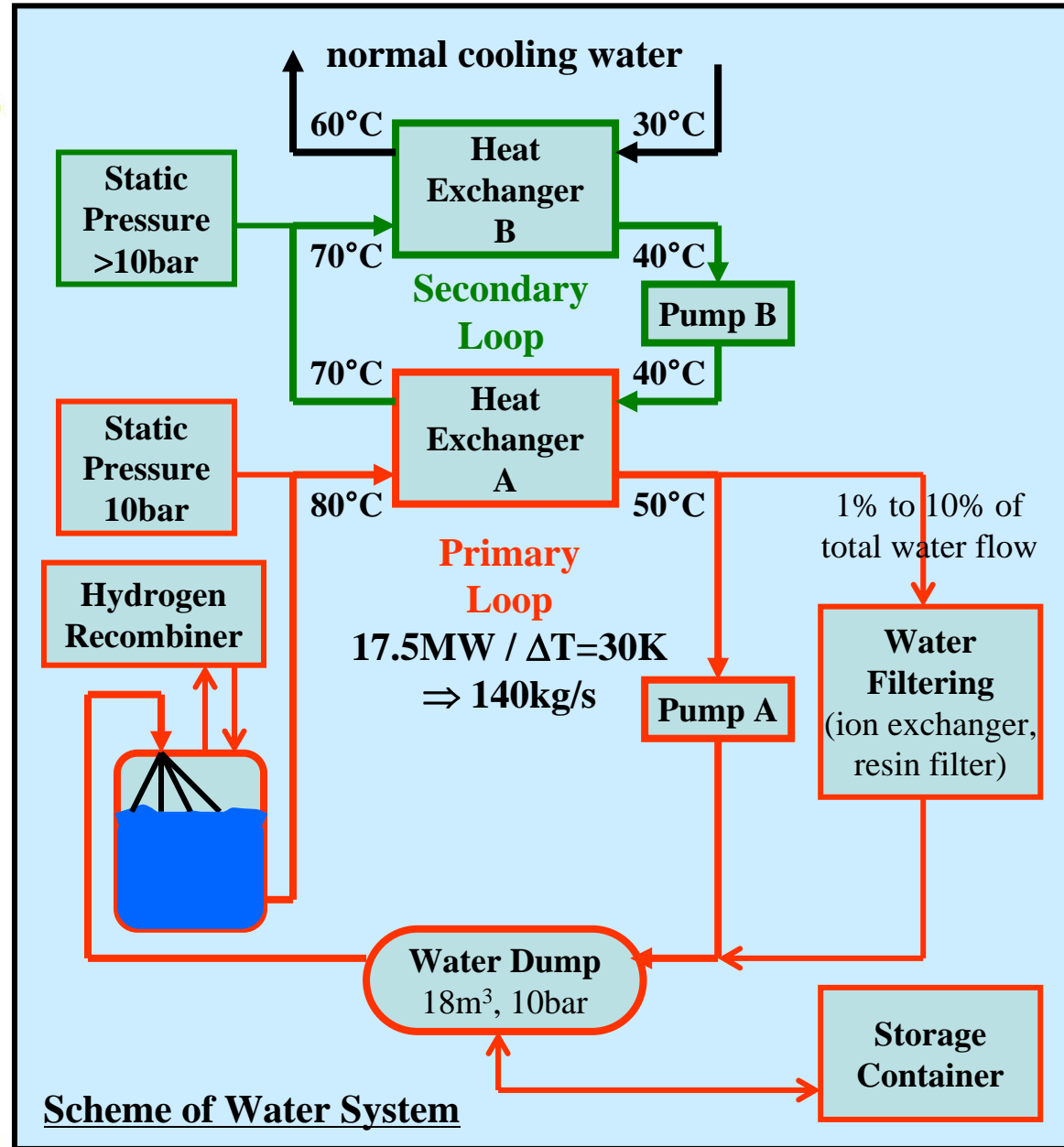

10 Bar H2O Dump Enclosure & Shielding 20 mrad

Elevation:
1.5m Dump Diameter
4m x 3m Enclosure

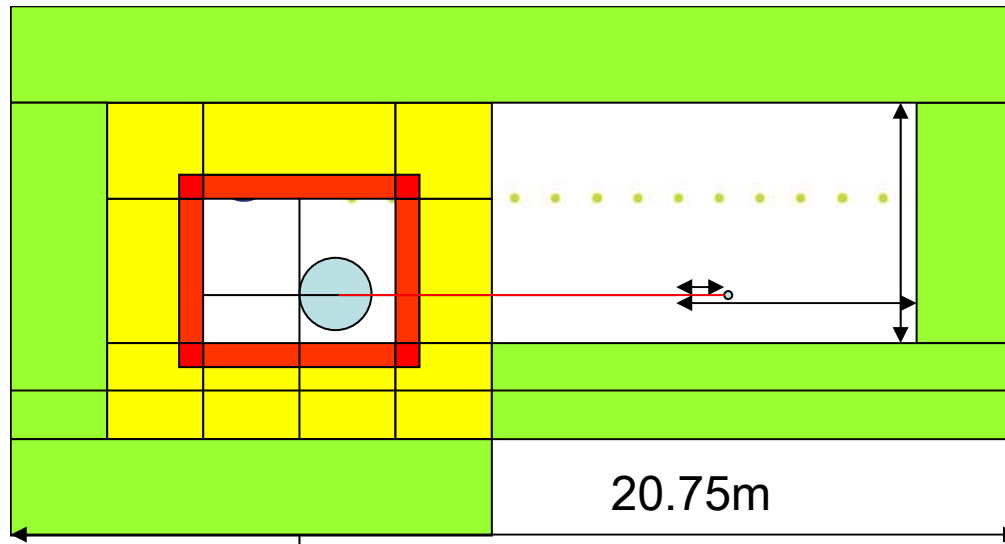

11m

20.75m

Shielding:
Red: 0.5m Fe
Yellow: 1.5m Boronated
Concrete
Green: 2m Concrete

Plan:
8m Long Dump
10m Long Enclosure

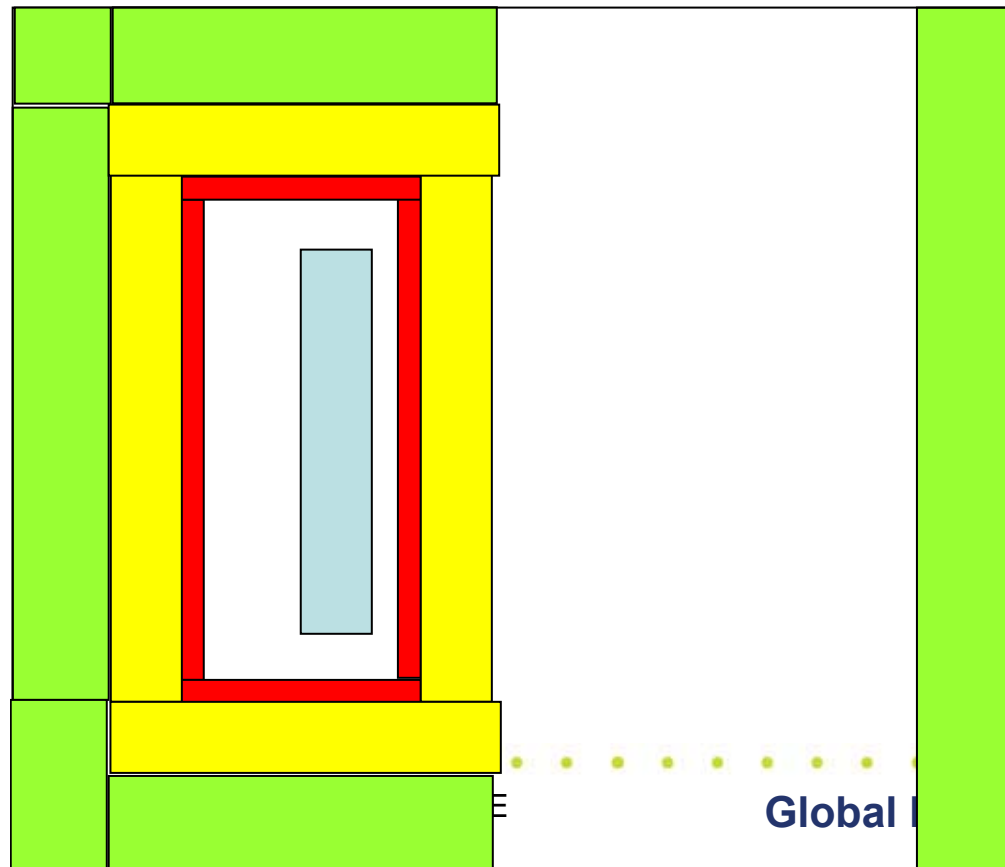

18m



Plumbing near 10bar H₂O dumps

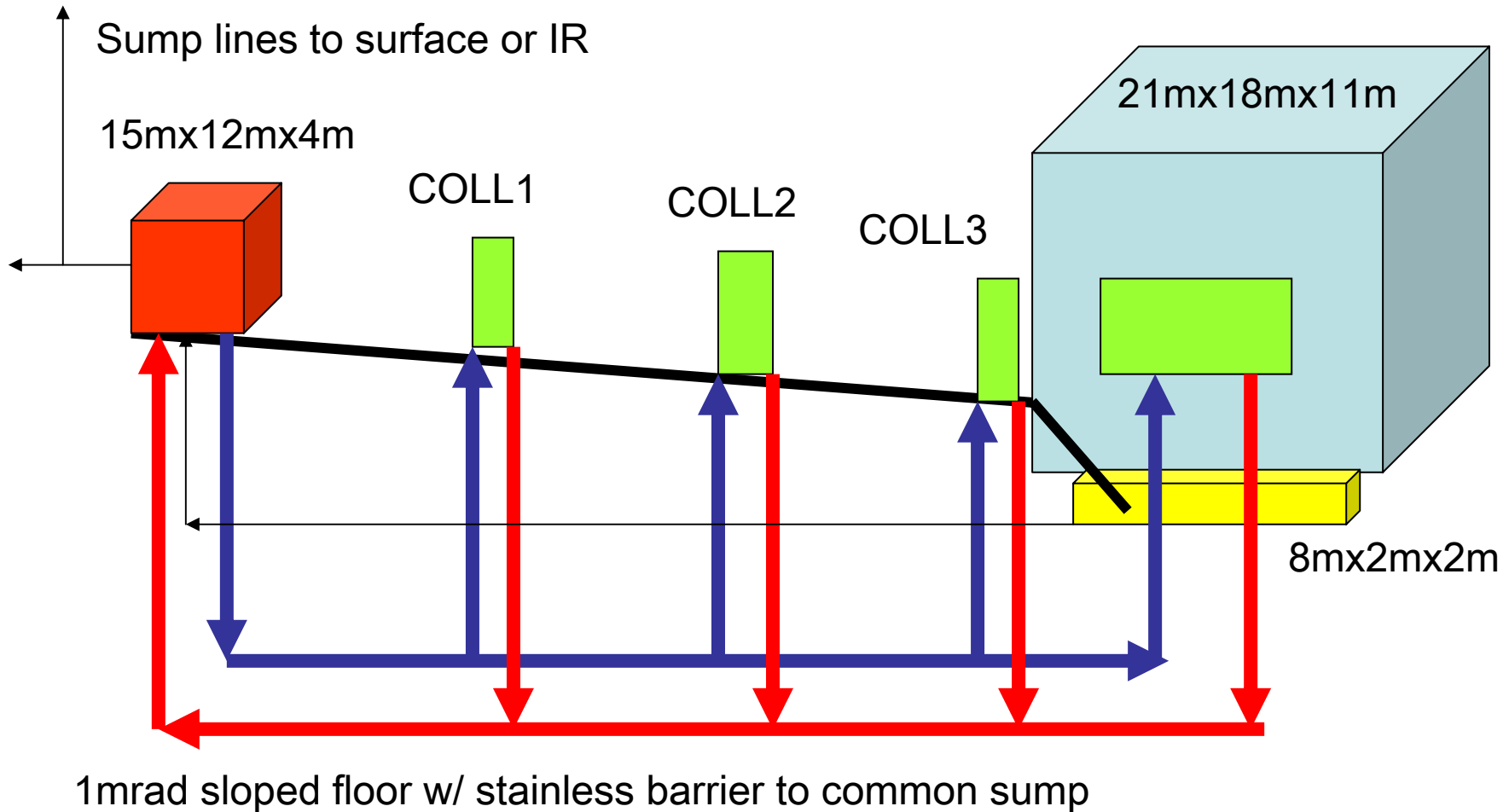

6" Supply/Return with ~2200gpm



2 mrad Extraction Layout

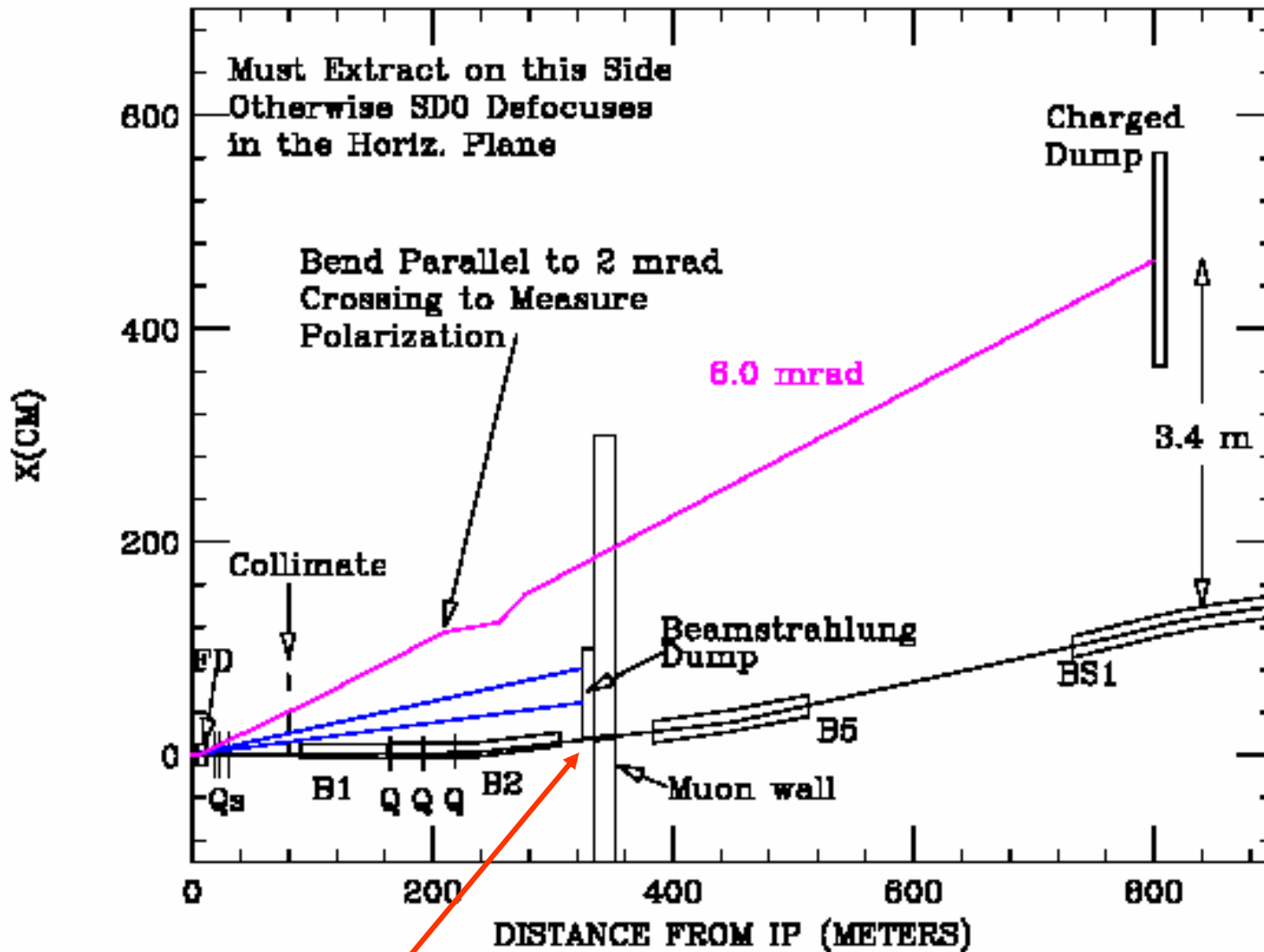

Note proximity of beamstrahlung dump to the incoming beam – may need to put the incoming beam line pipe through the water tank.



Parts List & Interfaces to CF & I&C Groups for 10 atm Water Dump

TS1	TS2	10 atm water vessel
D&C		Water Vessel
D&C		Water Vessel support
D&C		Vessel Window
D&C	I&C	Window Replacement Robot

TS1	TS2	Dump Housing
	CF	Dump Housing
	CF	Dump Housing Lights & AC Power
	CF	Fe Shielding
	CF	Near-Concrete sheilding
	CF	Far-Concrete sheilding

TS1	TS2	Pump Housing
	CF	Rad Water/LCW Pump Housing
	CF	Pump power

TS1	TS2	Sump System
	CF	Sump Housing w/ Stainless Steel Lining
D&C	I&C	Float & microswitches for sump pump
	CF	Stainless coated inclined ramp
D&C		Sump pump transfer line to holding tank in pump room
D&C		Sucking pump from sump to holding tank
D&C		Pushing (centrifugal pump) from sump holding tank in pump
D&C		1 surface container for rad water

TS1	TS2	Rad Water Loop
D&C		Rad Water Feed/Return
D&C		Pump
D&C		HX
D&C		Surge Tank
D&C		Polishing Loop
D&C		H2 recombiner
D&C	I&C	Remotely operated valves
D&C	I&C	Flow meter
D&C	I&C	Temp gauge
D&C	I&C	Pressure gauge
D&C	I&C	Pump controller

TS1	TS2	LCW Loop
D&C		Pump
D&C		HX
D&C	I&C	Remotely operated valves
D&C	I&C	Flow meter
D&C	I&C	Temp gauge
D&C	I&C	Pressure gauge
D&C	I&C	Pump controller
D&C	I&C	Radiation Sensor



More Dump Cartoons

50cm Diameter x 2m long
Aluminum Ball Dump with Local
Shielding

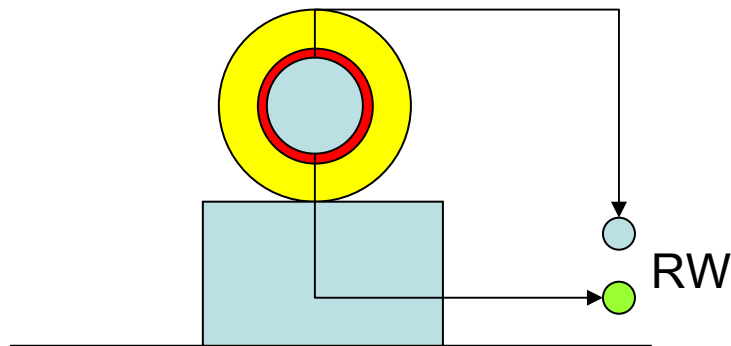

50cm Diameter x 50cm long
Peripherally-cooled Solid Cu or
Aluminium Dump (before local
shielding added)

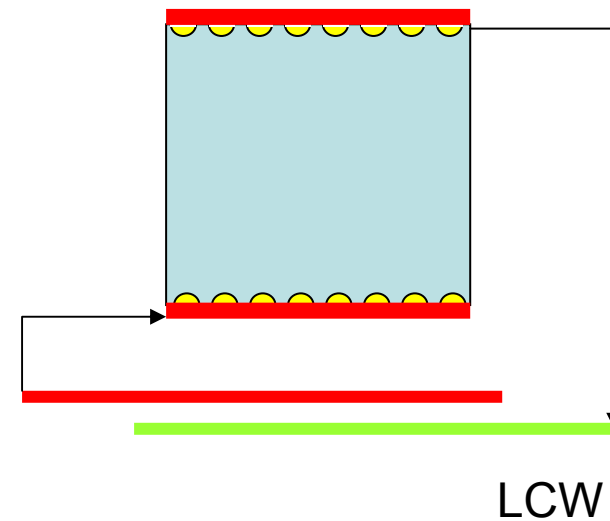



Collimator Cartoons

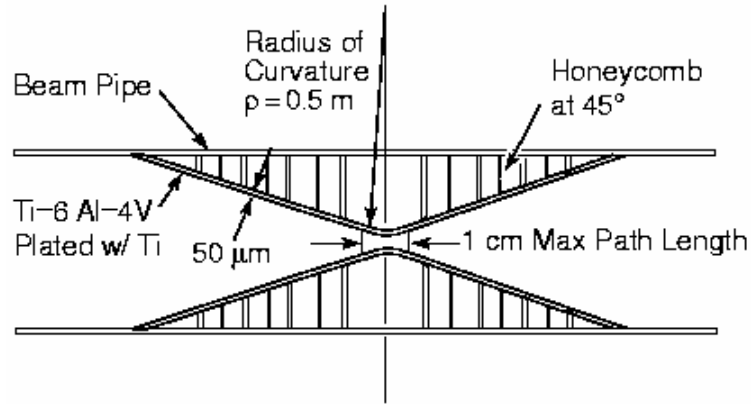

Tapered NLC Spoilers & Absorbers

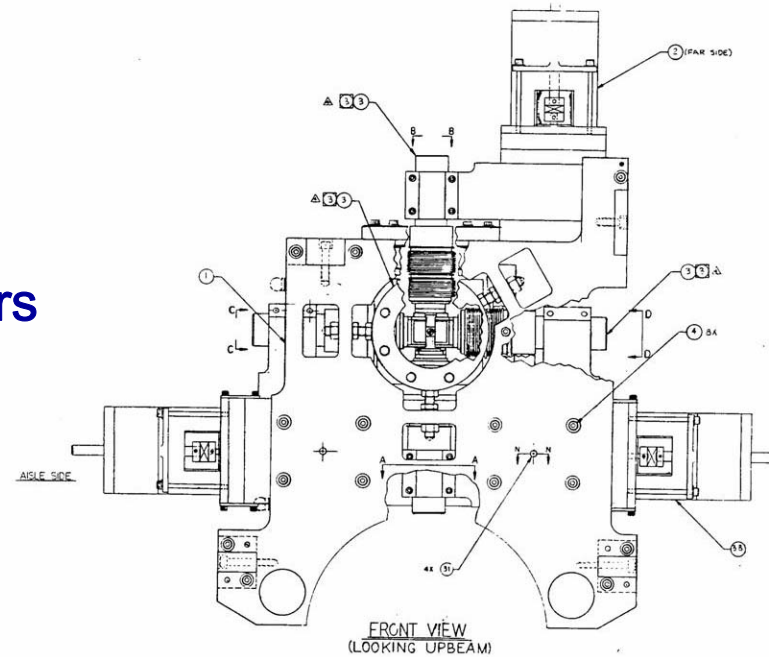
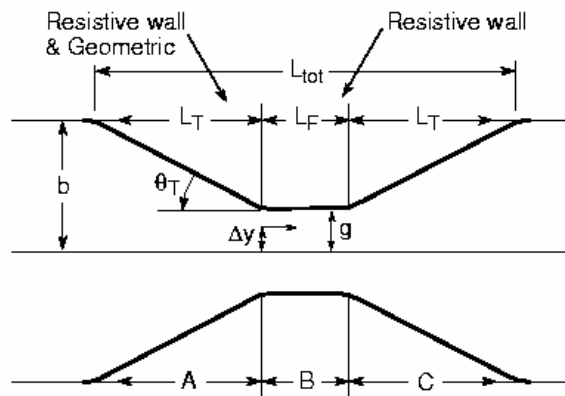

SLC Sector 30 4-Jaw collimator



Stopper Cartoons

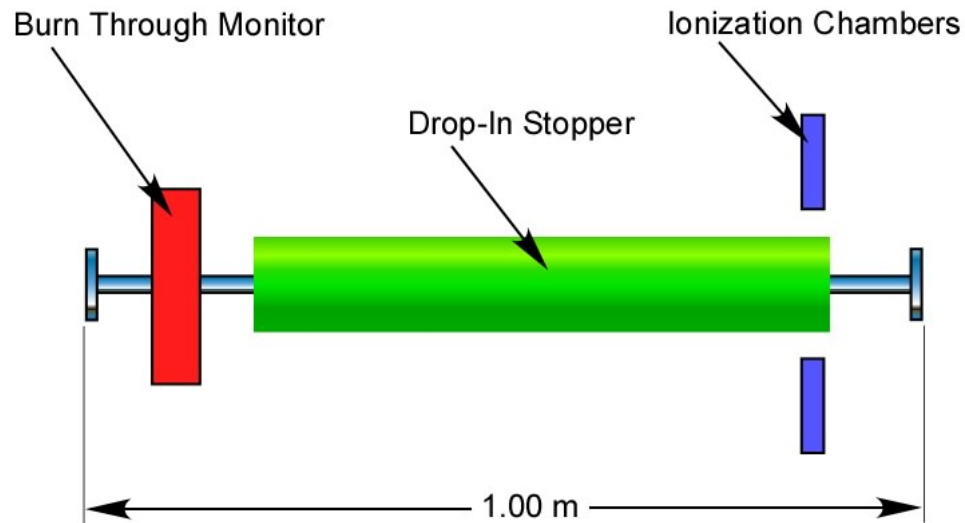

JC Sheppard Stopper

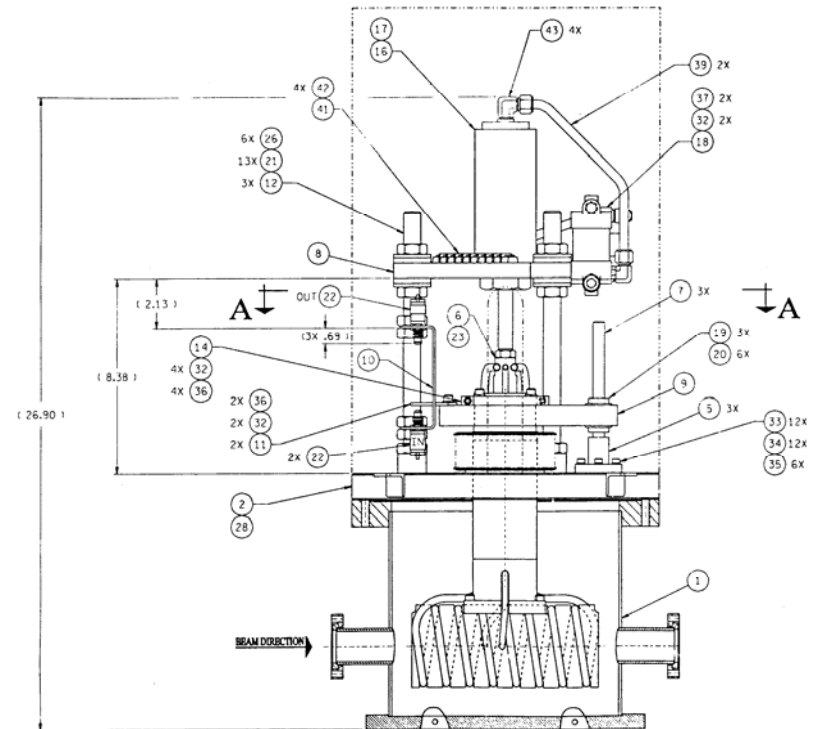

PEP-II Stopper