

# Front-End Electronics of ATLAS Tile Calorimeter and its Commissioning

Ilya Korolkov (IFAE), on behalf of Tile collaboration

## Outline

- **Tile Hadron Calorimeter (TileCal) in ATLAS**
  - ATLAS Imposed Requirements and Tile Calorimeter Concept
  - Status in the Experimental Cavern
- **Tile Hadron Calorimeter FE read-out**
  - Overview
  - Major FE Read-out Components
- **Integration of the FE read-out components**
  - Super-Drawer
  - Low Voltage Power Supplies
  - Quality Controls
- **Commissioning of the Tile FE read-out**
  - Status in the Experimental Cavern
  - Plans for the next year
- **Summary**

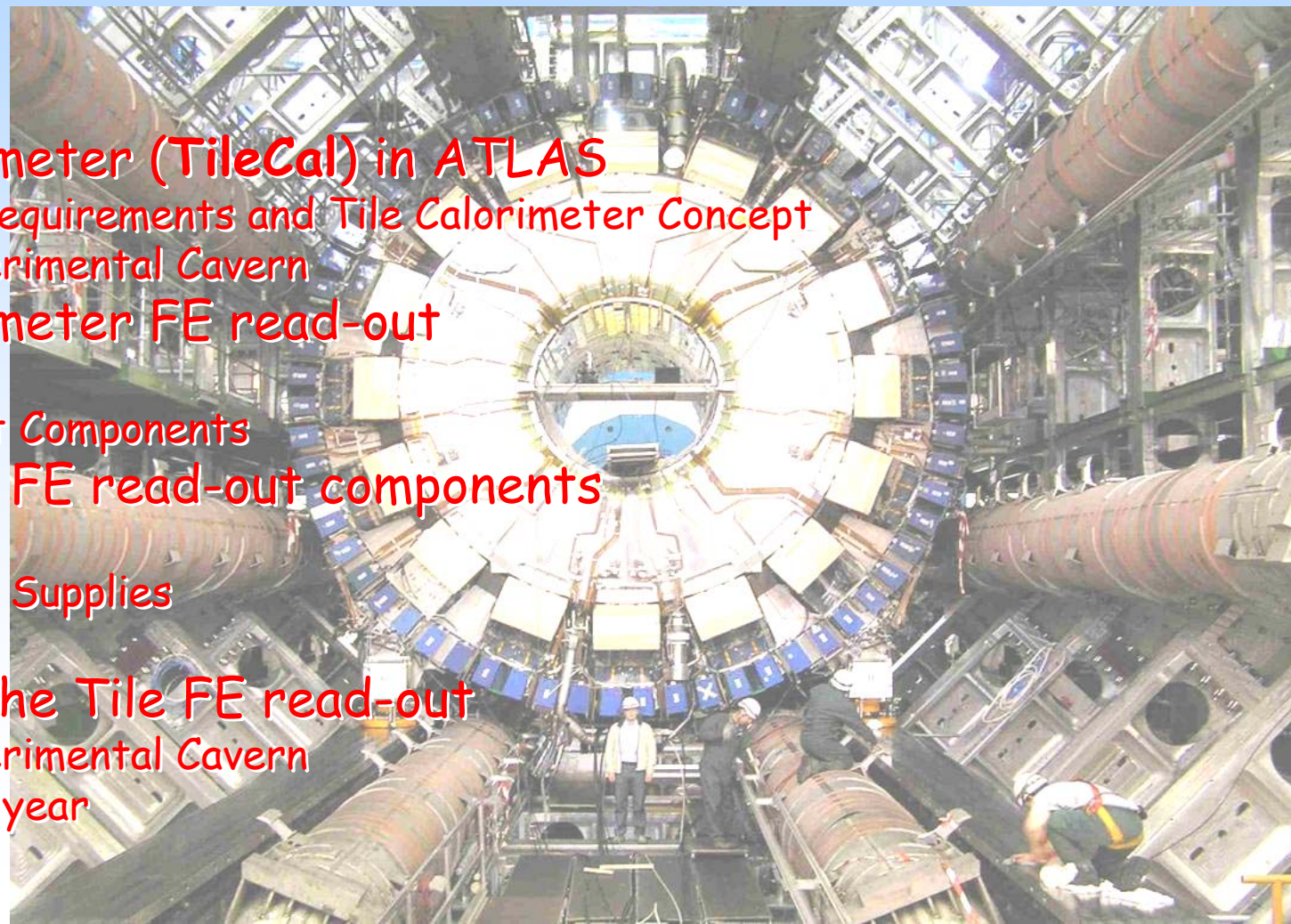

# Tile Calorimeter in ATLAS Detector at LHC

While the major goal of the LHC experiments is to find a definite answer on the mechanism of the EW symmetry breaking, the justified hope of the HEP community is also to see a hint of the physics beyond the SM. Based on this prospective the ATLAS detector was designed as a general purpose detector sensitive to a broad range of final states resulting from different models of "new physics".

**ATLAS Tile Hadronic Calorimeter plays a key role in the ATLAS physics program, specially for triggering and measuring jets and missing Et.**

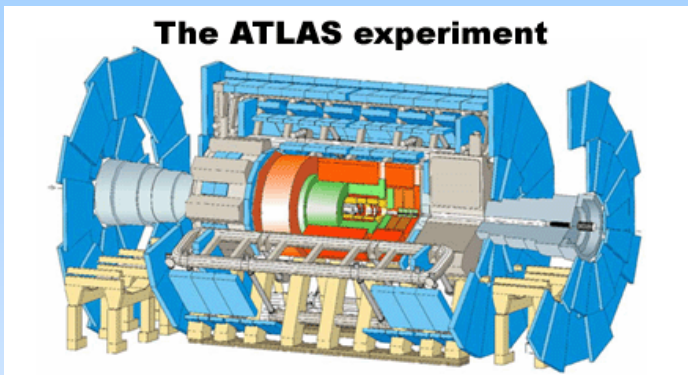

tF production at LHC

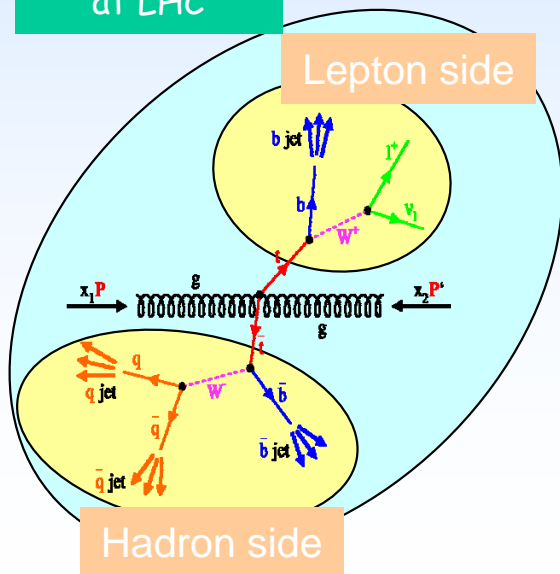

SUSY at LHC: squark/gluino production

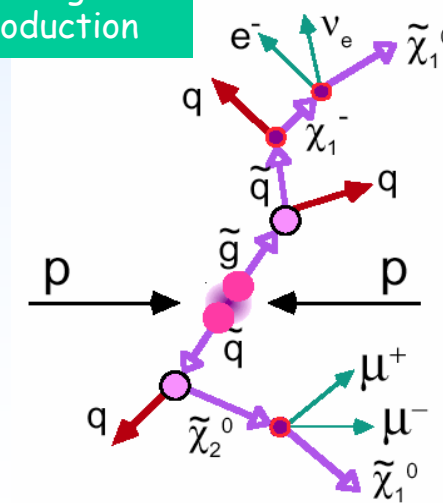

## ATLAS physics with the hadron calorimeter:

- Top physics: precise jet energy scale
- W physics: accurate ETmiss, rejection of EM-fakes
- Higgs: Jet reconstruction, rejection of muon fakes and EM-fakes, Etmis
- SUSY: reliable ETmiss measurement, jet reconstruction
- Exotics: precise jet energy scale at large energies

# Requirements Imposed on Tile Calorimeter.

- large center-of-mass energy of 14 TeV:
  - good jet reconstruction over a large energy range for the whole  $\eta$  range covered :  
 $sE/E = 50\%/\sqrt{E} + 3\%$
- large luminosity:  $10^{-34}/\text{cm}^2/\text{s}$ 
  - 23 MinBias interactions/BC
    - fine granularity
  - large radiation impact
    - radiation hardness of readout
- non-compensating calorimeter
  - reasonable longitudinal segmentation in order to recover linearity of energy response
- large jet cross section → efficient hadron leakage cut for EM-ID
  - fine granularity
- avoid ETmiss faked by detector effects
  - uniformity in  $\eta, \phi$
  - good hermeticity
  - containment of jets

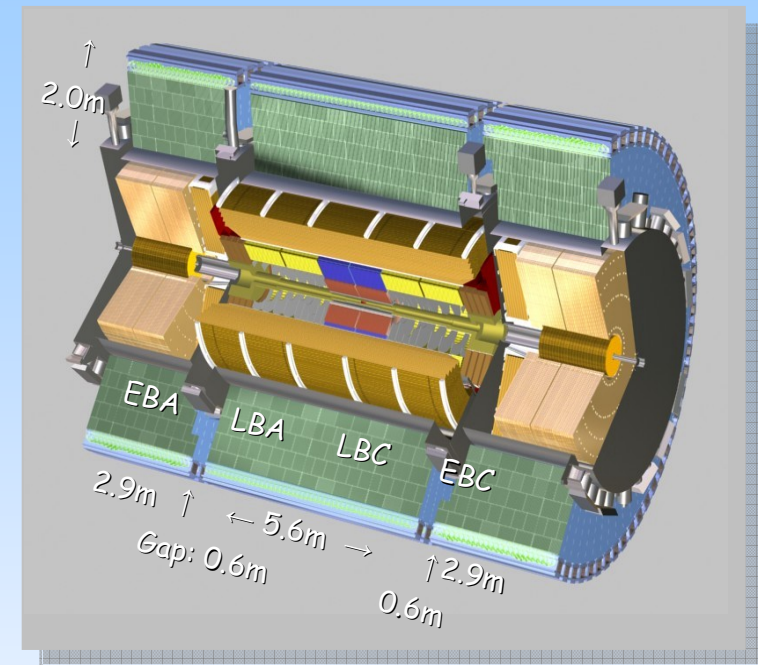

## Summary of requirements:

- Precise jet energy scale
- Good jet energy resolution
- Containment
- Hermeticity
- Uniformity
- High granularity
- Radiation hardness

# Detector Geometry.

## Hermeticity

$\eta$  coverage  $\pm 1.7$

cracks at transition region

$\gamma$  Intermediate Tile Calorimeter + Gap Scintillators

The TileCal, the barrel part of the hadron calorimeter in ATLAS, is a sampling device made of steel and scintillating tiles. Due to the LAR EM-calorimeter in front mainly the hadronic response is optimized. Some sensitivity to muons might be used in the level-1 trigger.

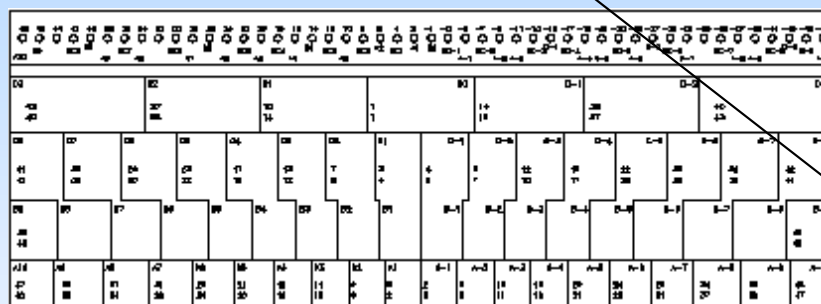
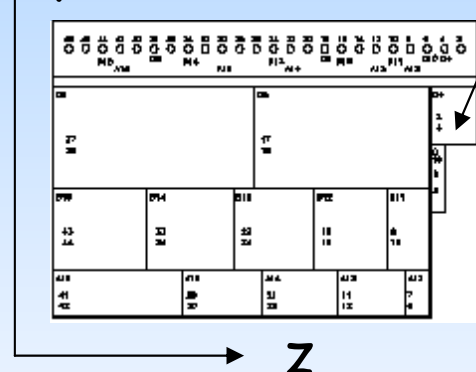
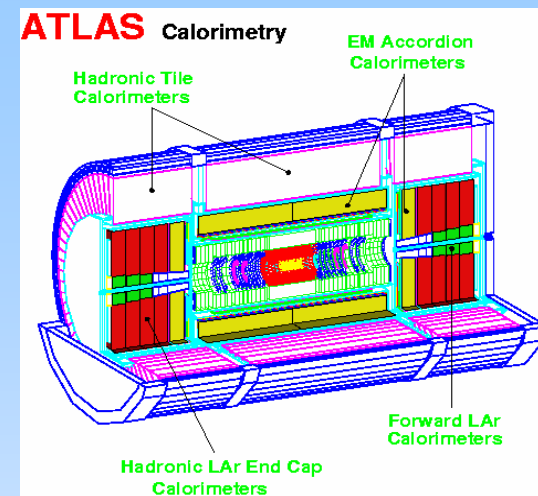

5.6 degree azimuthal slice

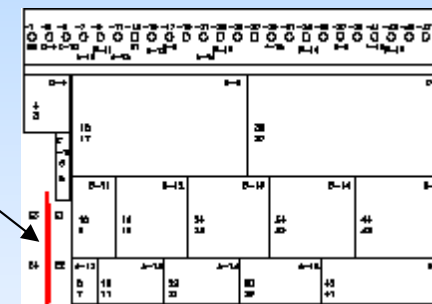

$\eta = 1.7$

## Segmentation

Each 0.1 azimuthal slice has 73 cells arranged into projective towers with  $\Delta\eta \approx 0.1$ . Each of 64X3 modules has three depth segmentations called samples A, B, and D.

## Sampling

18 mm period in z with radial tiles staggered in depth.

local variations in sampling fraction for  $|\eta| < 0.1$

## Material budget

to contain jets and to shield muon system.

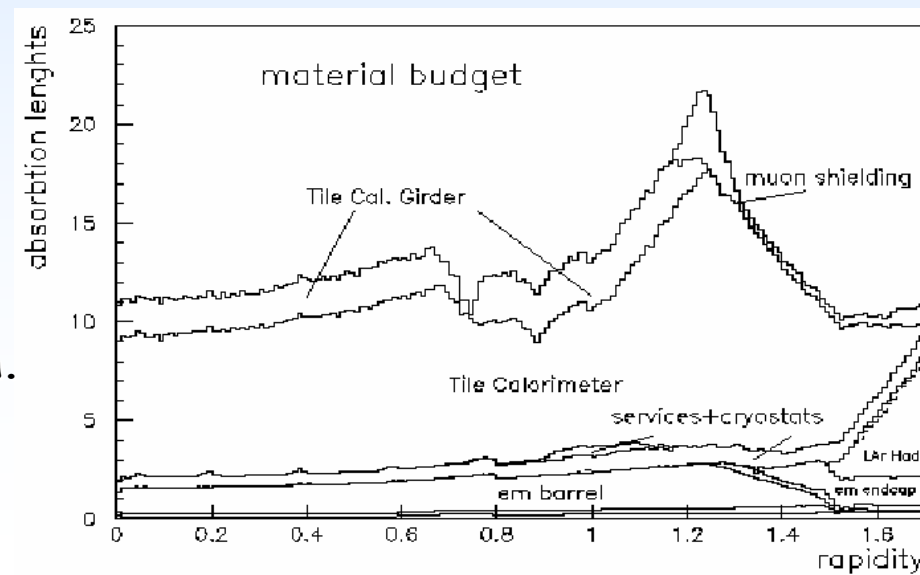

# Mechanical Status of Tile Calorimeter in the Cavern

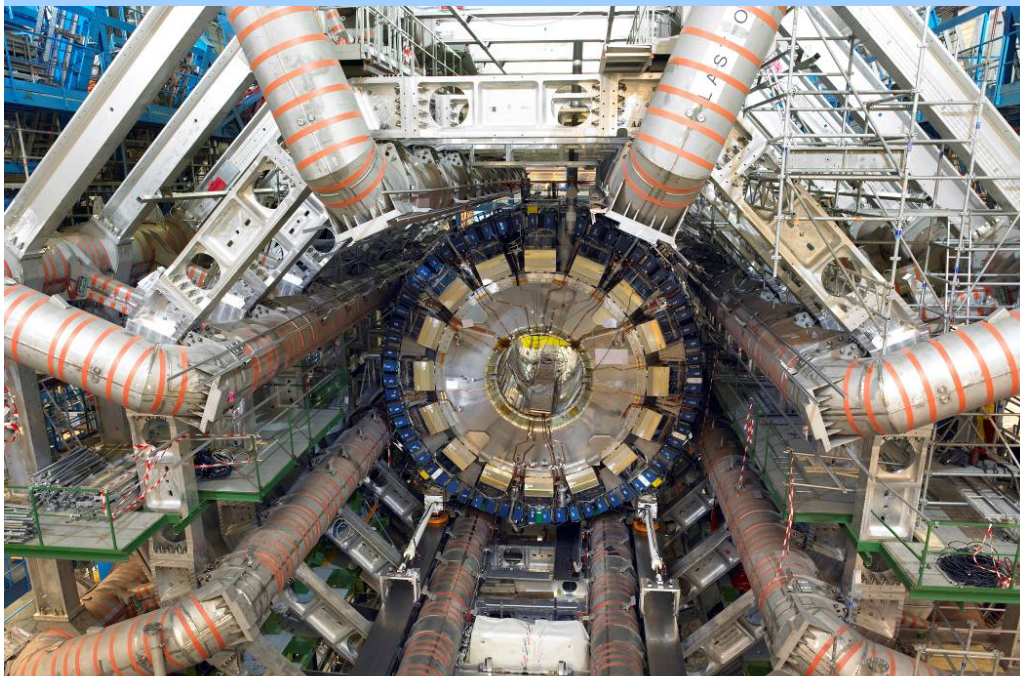

## The Barrel

is complete and placed in its final position, with services and cabling fully installed on 5/16 part of the calorimeter and greatly advanced on the rest of the cylinder. Cooling is done on the 10/16 part of the barrel.

## Two Extended Barrels

are complete and to be moved towards Barrel next month. Cabling preparation has started.

The installation of the **calibration system based on the movable Cs radioactive source** is mostly complete on all three cylinders.

**Gap and Cryostat scintillators** are installed on the *C* side and the calibration effort is taking place.

# Tile Read-Out Scheme

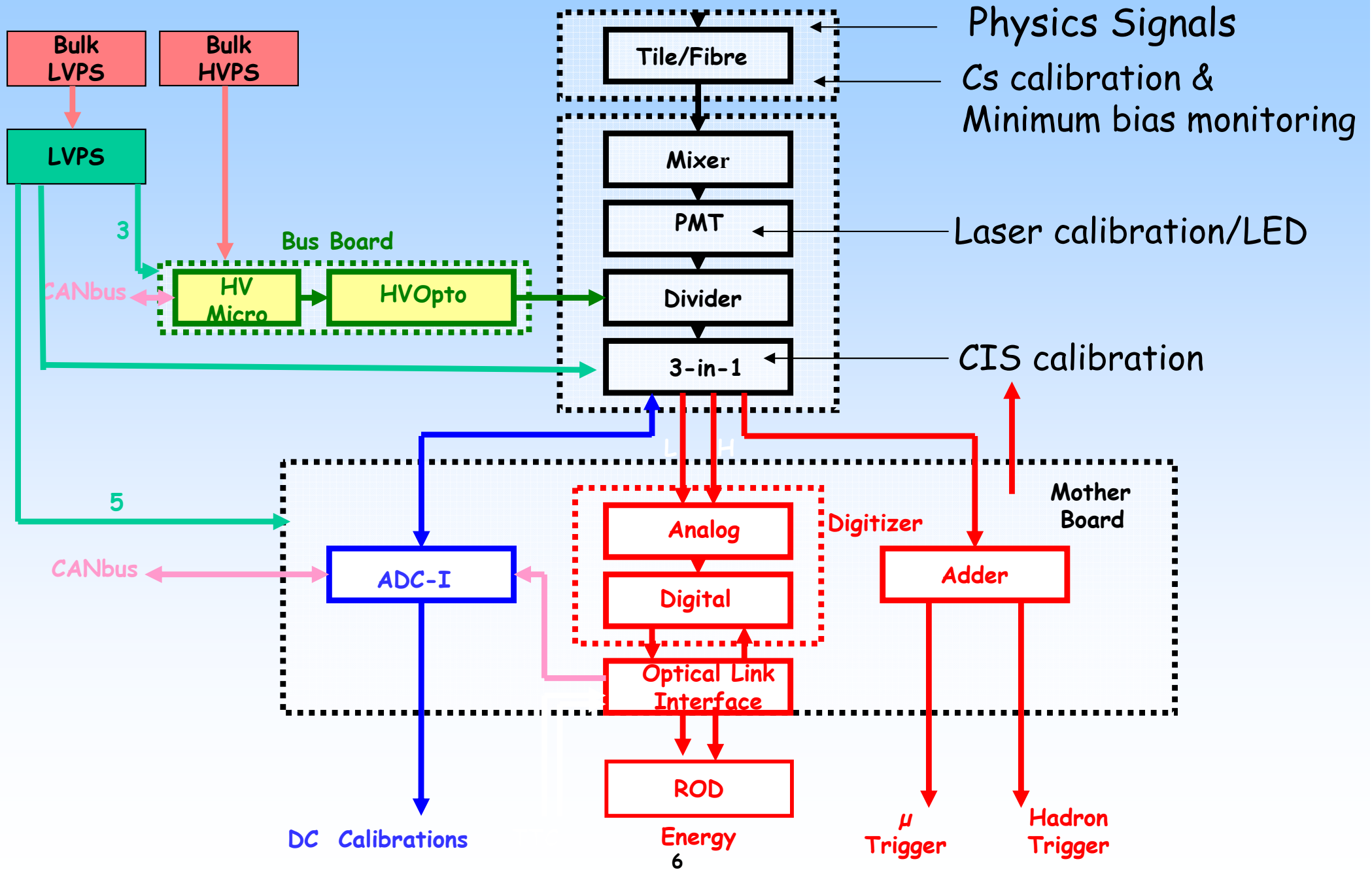

# 3in1 Card

3-in-1 card: plugged into anode of each PMT (1 channel = 1 PMT), named for its multiple functionality, ~10000 cards in TileCal

Shaping of PMT signal to digitizers

Typically 7-9 25ns samples digitized

Bi-Gain output (gain ratio 1:64 for dual 10-bit ADC's)

high gain (0-10 GeV)

low gain (10 - 1000 GeV)

Integrator for  $^{137}\text{Cs}$  source calibration and monitoring minimum bias current.

six gains selected remotely (12pA-1.7uA)

10msec integration time

Charge injection (CIS) for electronics calibration

Example digitized 3-in-1 pulse shape from one channel responding to CIS

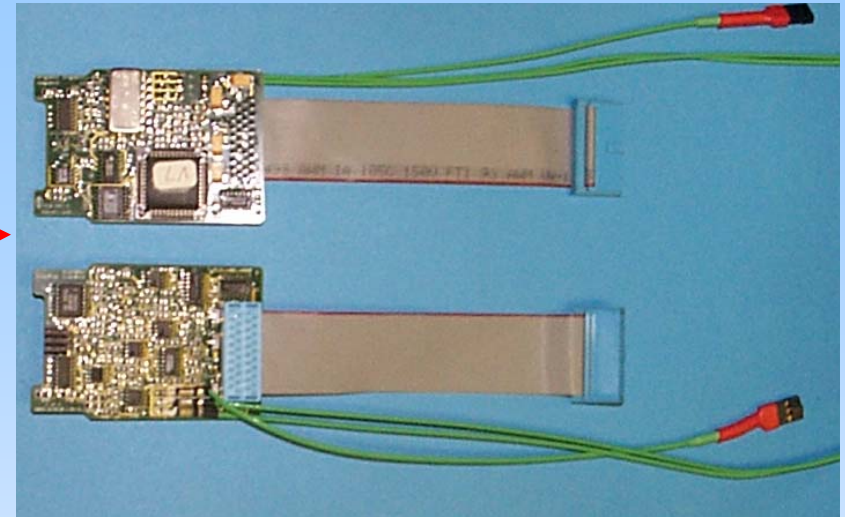

ADC Counts

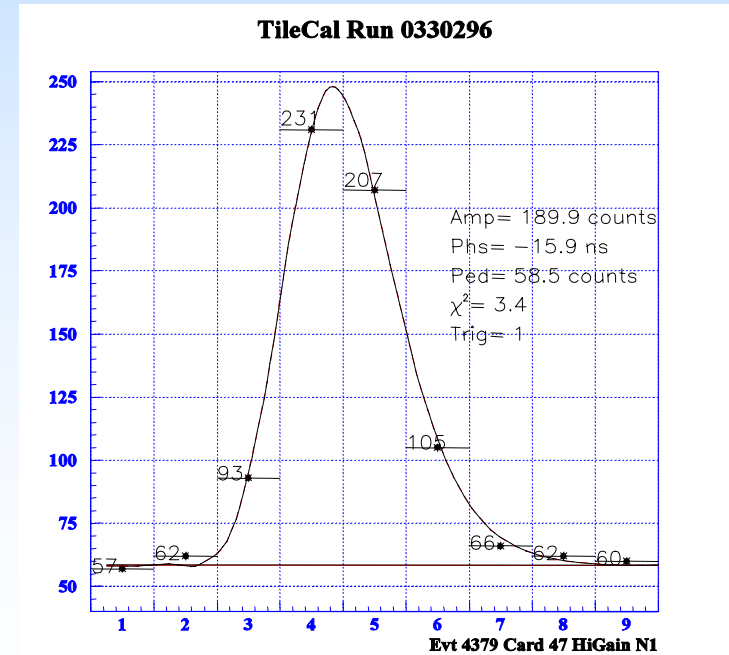

Digitized Samples (25 ns bins)

# Digitizer Card

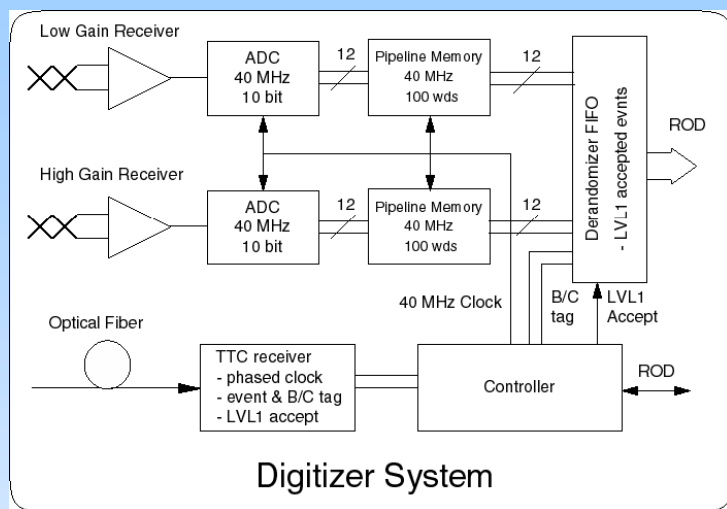

Six 3in1 channels per digitizer board  
~1600 cards in the TileCal

Two 10-bit 40 MSPS ADC's per channel  
Digitizes pulses from both gains of  
3-in-1 card every 25 ns

LVL1 trigger latency  $< 2.5 \mu\text{s}$

Digital pipeline

Readout 7 or 9 samples of 25ns

Control via custom chip (TileDMU) from Chip  
express, 20K gates, coded in VHDL

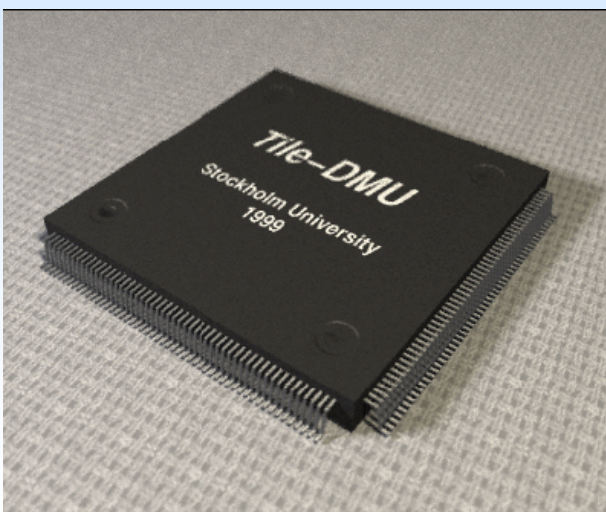



# Adder Card

Analog outputs to LVL1

Hadron

$\mu$

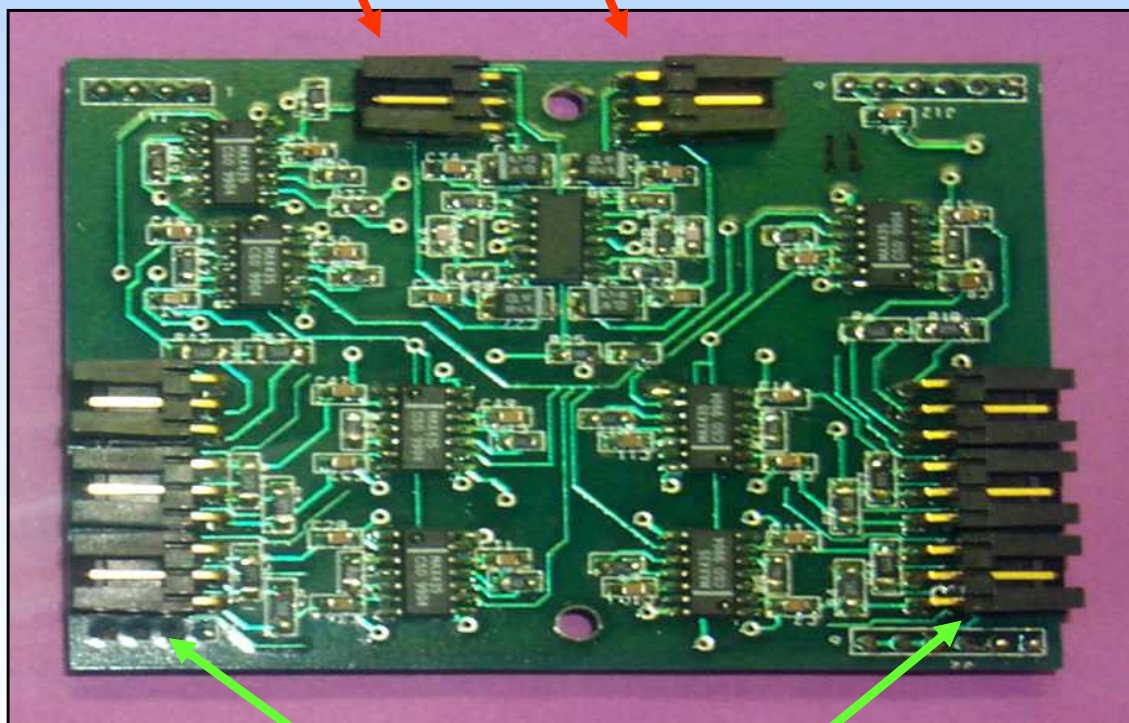

6 inputs from 3in1s

TileCal LVL-1 signal consists of

**adder tower sum** (calorimeter trigger) - analog sum of PMT signals in the given  $\eta, \phi$  direction

**muon output** - amplified analog signal from 1 PMT of D-sampling

adder tower sum:  $10 \text{ mV/pC} \pm 3\%$

noise:  $3.7 \pm 0.9 \text{ mVrms}$  (5 inputs)

adder muon output:  $280 \text{ mV/pC} \pm 5\%$

noise:  $45 \pm 5 \text{ mVrms}$  (1 input from D cell)

Timing for physics (alignment of the trigger tower inputs):  $< 2 \text{ ns}$

checked in the testbeams  
calibration is part of the  
commissioning program

# Interface Card

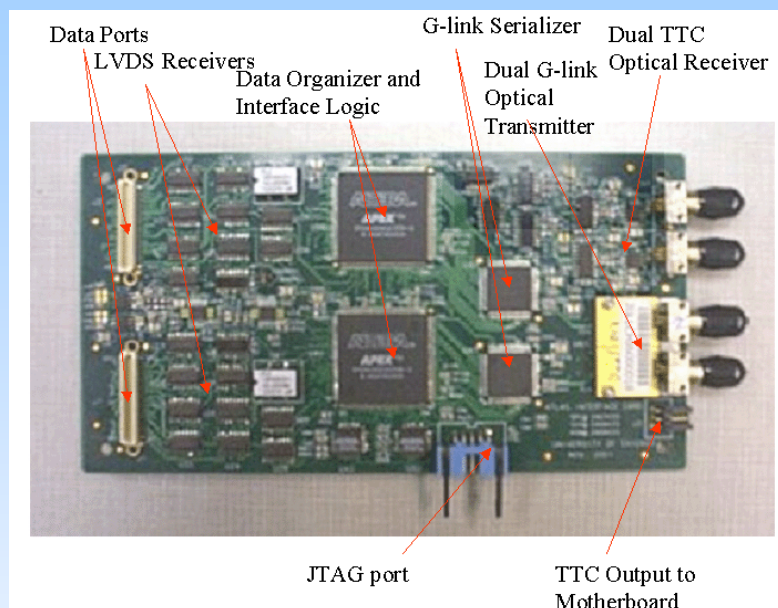

Interface card receives data from digitizers  
 2 PLD's format data  
 2 GLINKS transmit over optical fiber to ROD  
 Input TTC 40 MHz LHC clock  
 Repack 32-bit data words

From scrambled data transferred over  
 2-bit LVDS data lines (40Mbps)  
 Insensitive to timing differences  
 related to digitizer board geometry

Generates CRC-16 and Global CRC

Check transmission errors over input and  
 output segments

Redundant design

Dual optical inputs

Interface automatically selects  
 other TTC input if 1 fails

Dual optical GLINK output

In case a fiber breaks

Dual logic

Robust against transient SEE  
 events

Altera EPC2 programmable in-situ via JTAG port

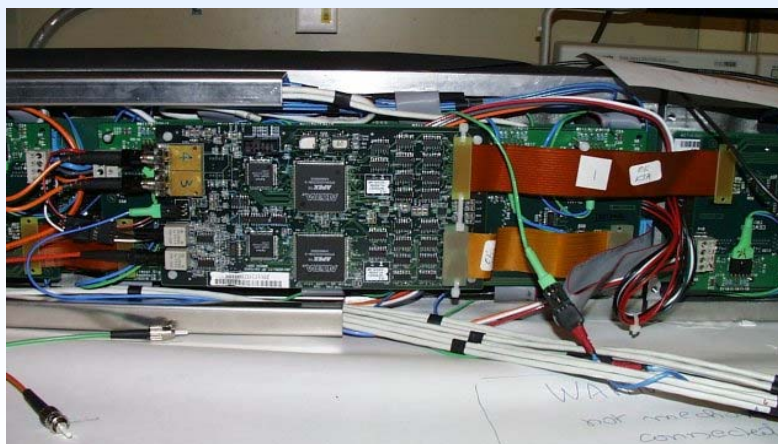

# Motherboards, Integration of the Tile FE Components in the Drawer

## Mother Boards

Set of four chained motherboards per drawer

Up to 12 channels per motherboard

~1000 Motherboards in TileCal

Services and control signals to 3-in-1

Digitizer Boards, set of 8 per drawer, 6 channels per digitizer

Interface Cards, One per drawer

Connections to drawer D.C. Power & CANbus

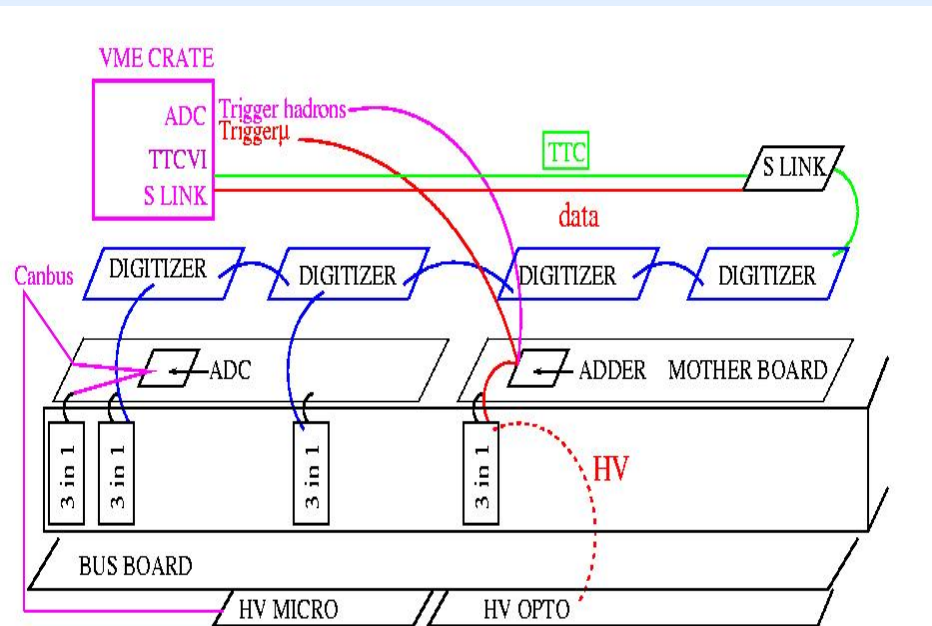

## Drawer

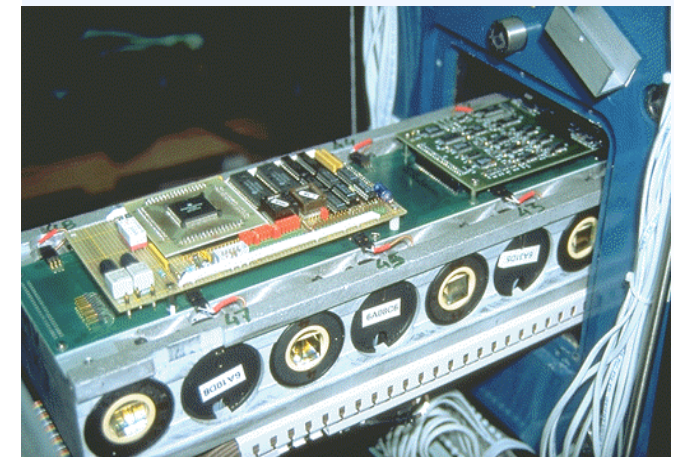

# LV PS system (power branch)

## Main Power supply (Bulk PS)

3x200 V DC, 1kW/channel (max. 1.7kW)

22/64 pieces are in the cavern

## 200 V & AUX Star boxes

all are produced, installed for the Barrel

## LV Box

Integrates **8 bricks** in the **metallic boxes** with  
**heat sinks** - all are produced

**fuse boards** - all are produced

**internal cable sets** ~70% done

all small items to Build LV Boxes are in hands

21 "final" LV boxes are in the cavern, to be  
40 by the end of June, to be used to  
commission services on entire Barrel

## Bricks

DC DC converters to 3,5,15V, 2048 pieces, 8pc  
per LV-BOX, home made transformer

Later comer,

working prototypes were given to users at the cavern in Aug'05.

Many improvements since then, based on the user experience.

Goal is to finalize the performance tuning and go into full speed assembly in few months. Big fraction of bricks (>90%) is in stock awaiting final tuning.

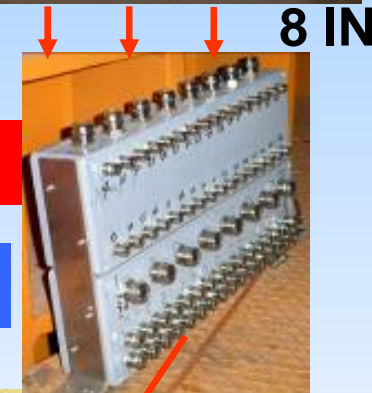

200 V star box

AUX star box

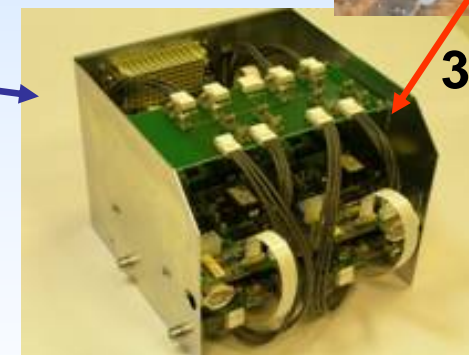

# Drawer Insertion, Cabling, LVPS Insertion

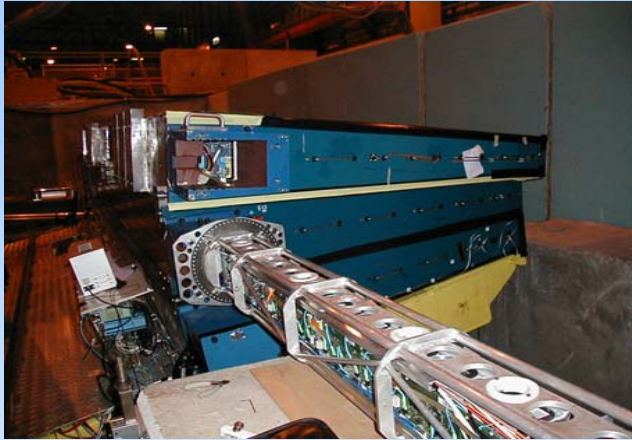

1)  
Drawer is inserted in the module  
All drawers are already inserted



4)  
LV PS to be connected to the drawer  
40 LVPS to be in the cavern by July

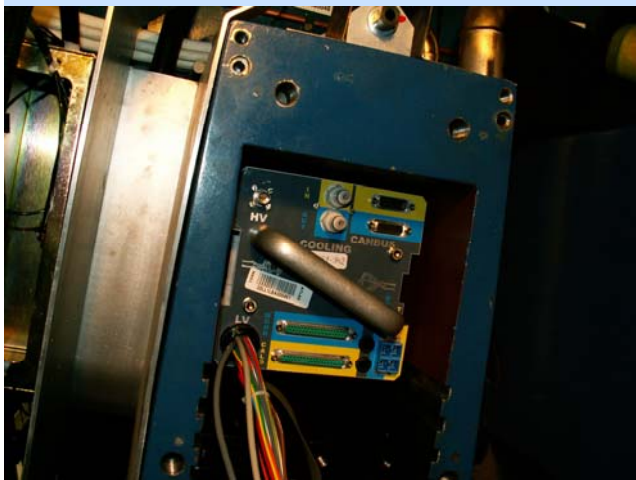

2)  
Drawer is ready for cabling



5)  
LV PS connected to the drawer  
21 Barrel modules are currently powered

3)  
Drawer Cabling started  
~3/16 of the TileCal is fully cabled

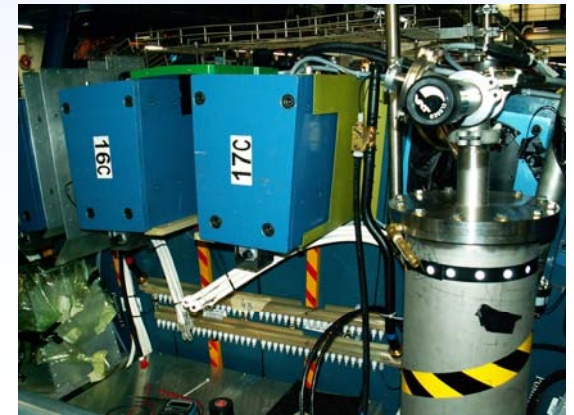

6)  
modules are closed and light sealed

# FE QC and Commissioning Scheme

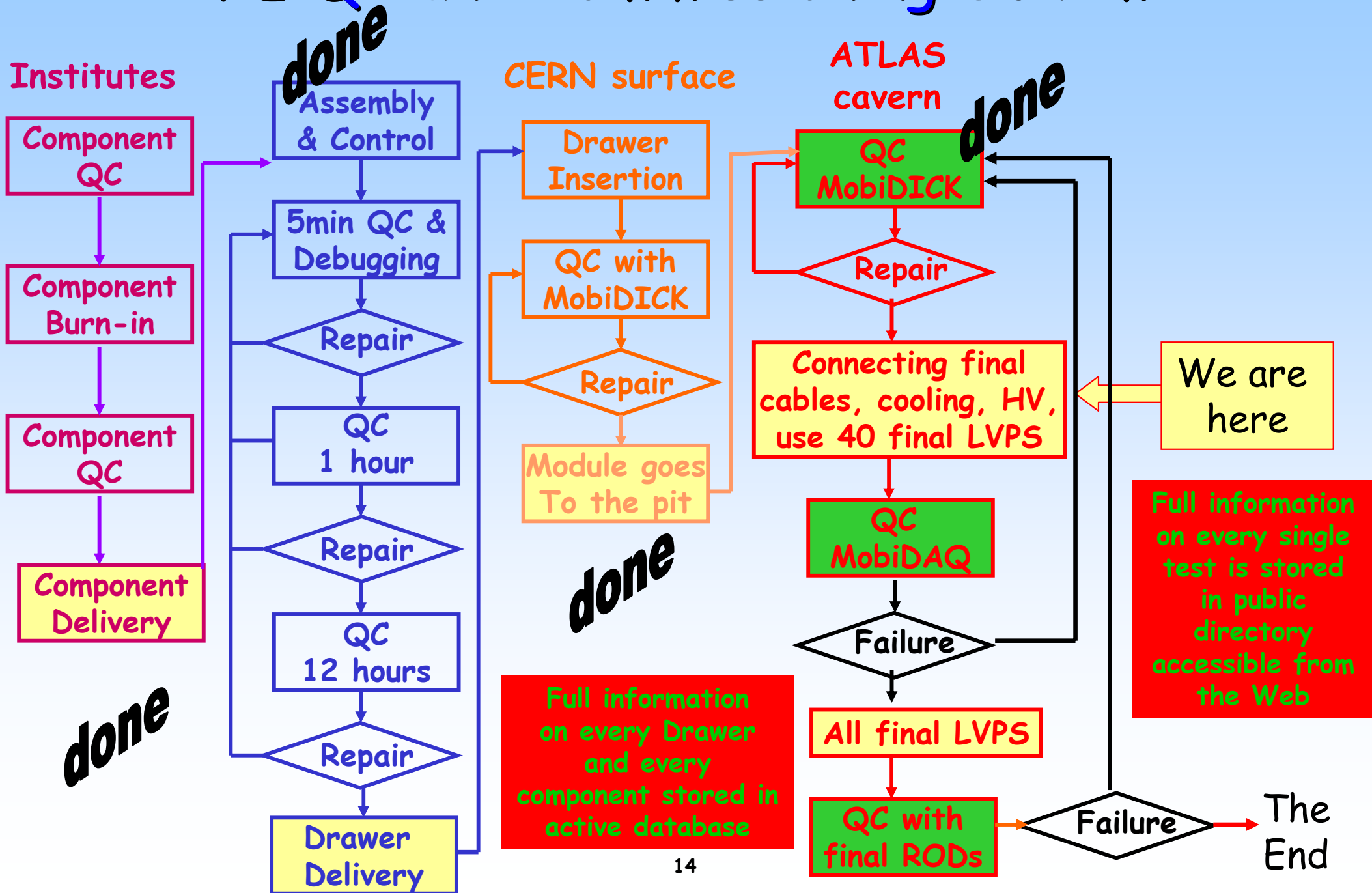

# QC Stations: MobiDick, MobiDAQ, RODs

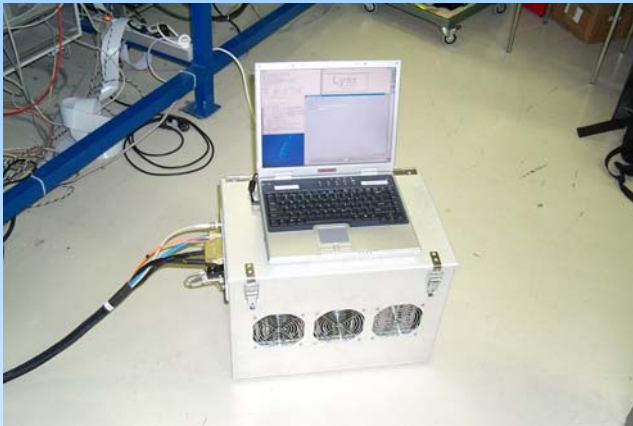

MobiDick

Detailed tests of all FE electronic components of a single drawer.

Used both before and after the installation in the pit

Used to verify any additional failure caused during commissioning and to certify the repairs

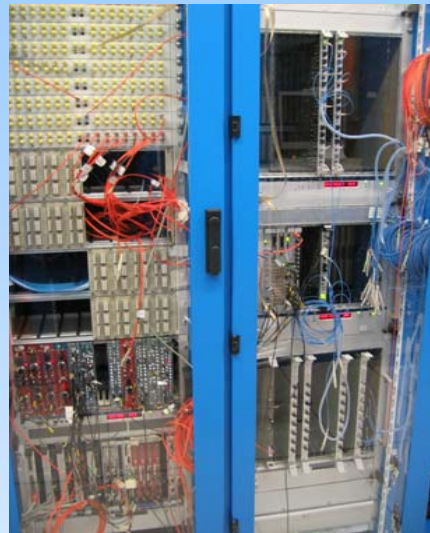

MobiDAQ

Mobile DAQ station that mimics all functions of the final read-out. It allows data taking with a set of 8 drawers at once.

Besides electronic checks, it was used to develop commissioning software tools.

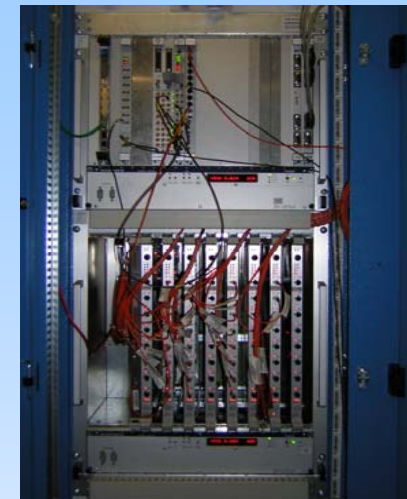



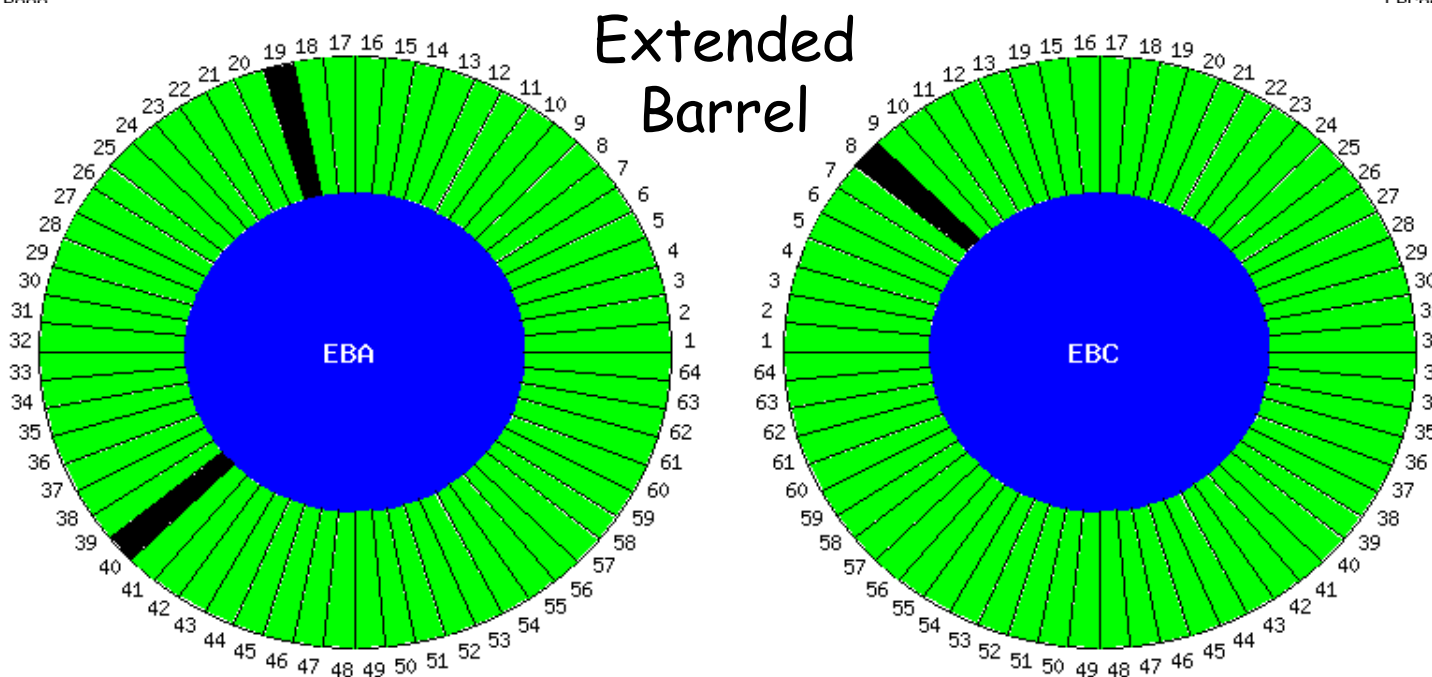
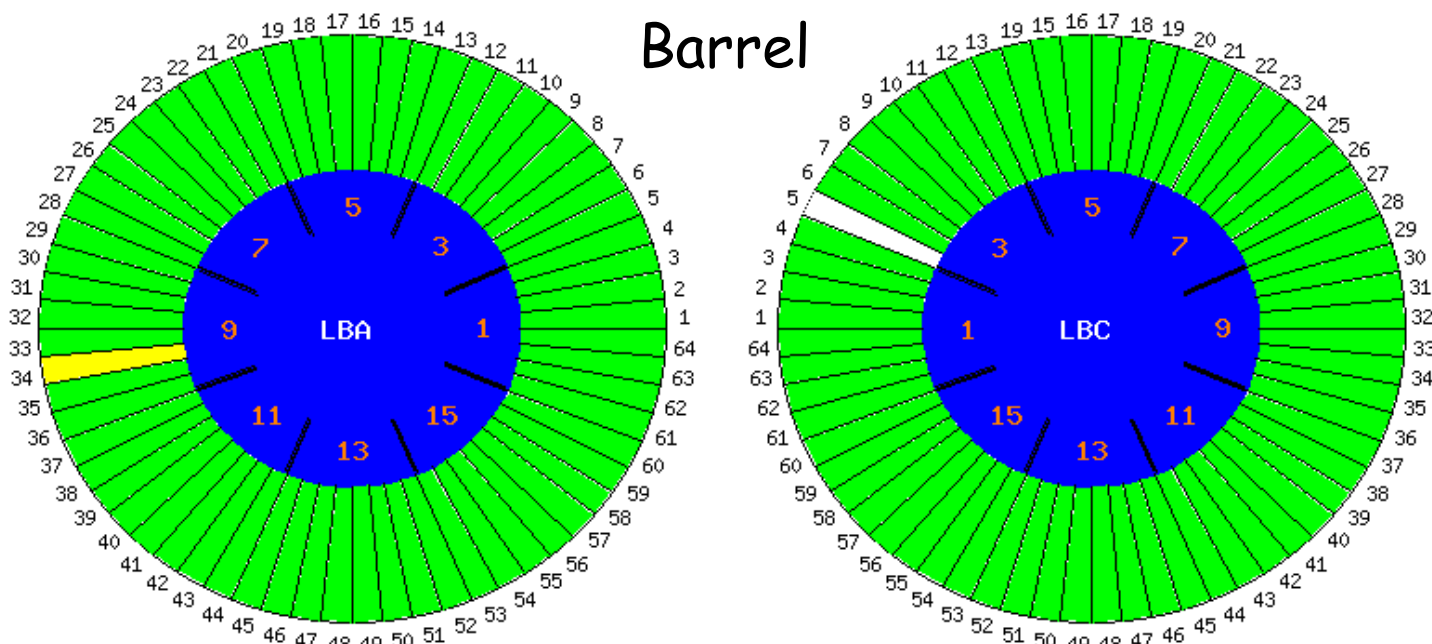

Final BE read-out, RODs

Capable of reading all Tile Calorimeter channels at once. All commissioning tools developed with moviDAQ were duplicated in RODs. Undergoes final debugging. Can take over the commissioning load or be used for dedicated studies in parallel.

# Status of the Tile Calorimeter FE Electronics. (as on June 07)



-  To be tested
-  OK
-  Almost OK
-  To be repaired
-  Extracted



# Summary.

The Tile Calorimeter was designed with powerful capabilities of triggering and measuring jets and missing Et. It is essential element of ATLAS physics program. The calorimeter geometry and principles were optimized for the best hadronic performance in a combined operation with other ATLAS calorimeters.

Barrel cylinder is assembled and placed in its final position. The routing of the cables and connection to FE patch panels is completed in 5 out of 16 barrel sectors. Big fraction of the Barrel cooling is available. Both extended barrel cylinders are fully assembled and soon will be moved towards the central part. Manufacturing and routing of the cables is starting. GAP and cryostat scintillators are installed on the C side.

Practically all the Tile Calorimeter modules are equipped with FE electronic components those functionality is systematically checked with several dedicated test stations. The FE electronics of the Tile Calorimeter is mostly commissioned in the stand-alone mode. Commissioning with final services and LV power supplies will follow.

# Back-up Slides:

# The TileCal detector

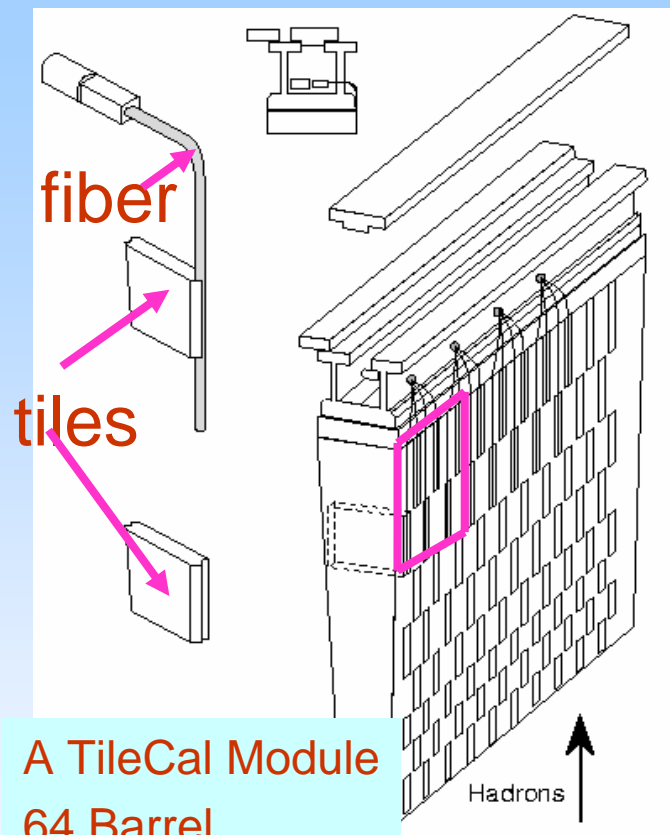

A TileCal Module  
64 Barrel  
2x64 Ext. Barrel

8.5 m outer diameter  
12.2 m long  
2900 tons  
10000 channels

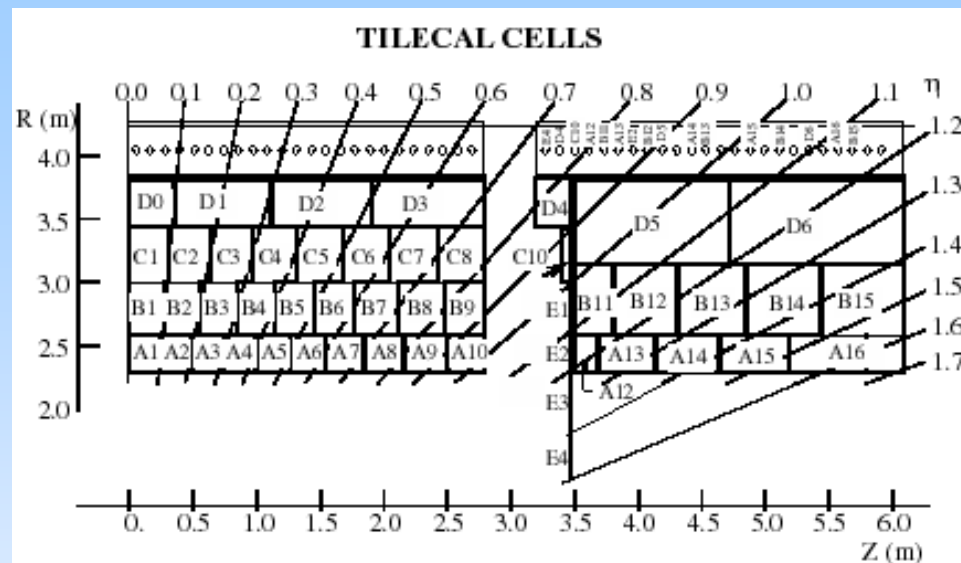

- Sampling calorimeter:
  - absorber: steel tiles
  - active material: scintillating tiles
  - laminated structure with tiles perpendicular to beam axis,
- The two outside faces are read out by wave length shifting (WLS) fibres into separate PMTs → increase light yield, provide redundancy
- Tiles grouped to cells of  $\Delta\eta=0.1(0.2)$ 
  - Cells arranged into projective towers
- PMTs and FE electronics on removable drawer in the back-beam

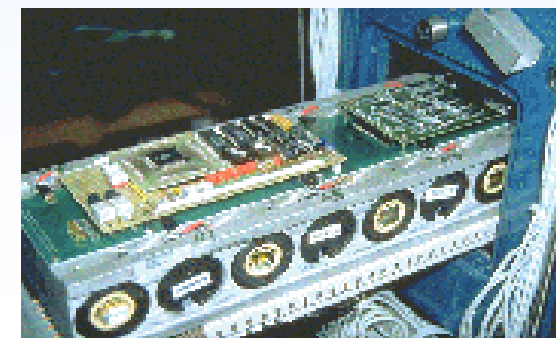

# Aug-2001 Laser Data

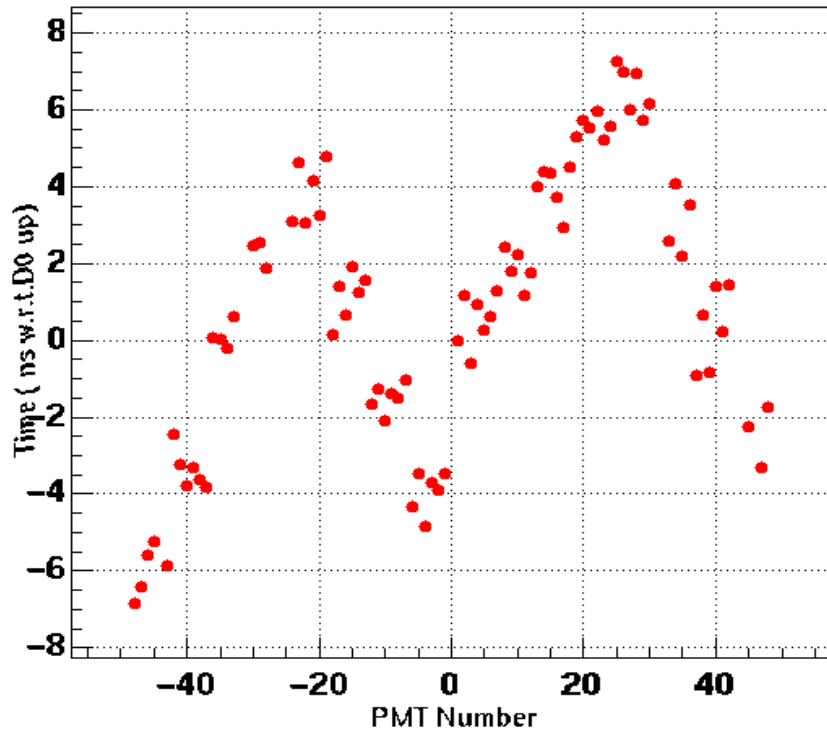

Using a simple and very fast timing algorithm, the distribution of the timing of PMTs has a spread of 0.7 ns once that the TTC clock modulation effect is removed.

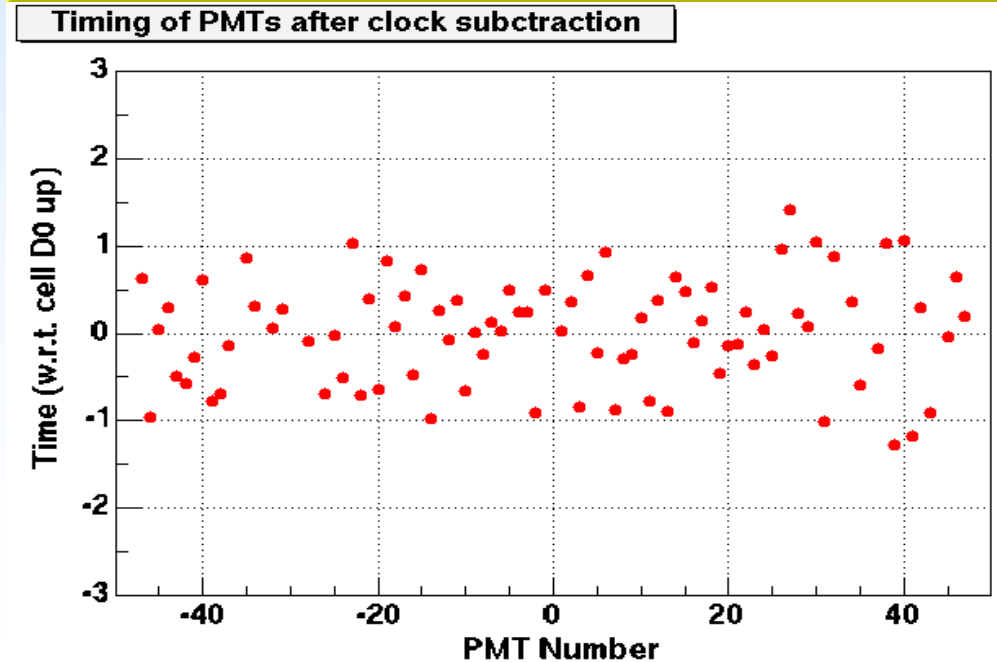
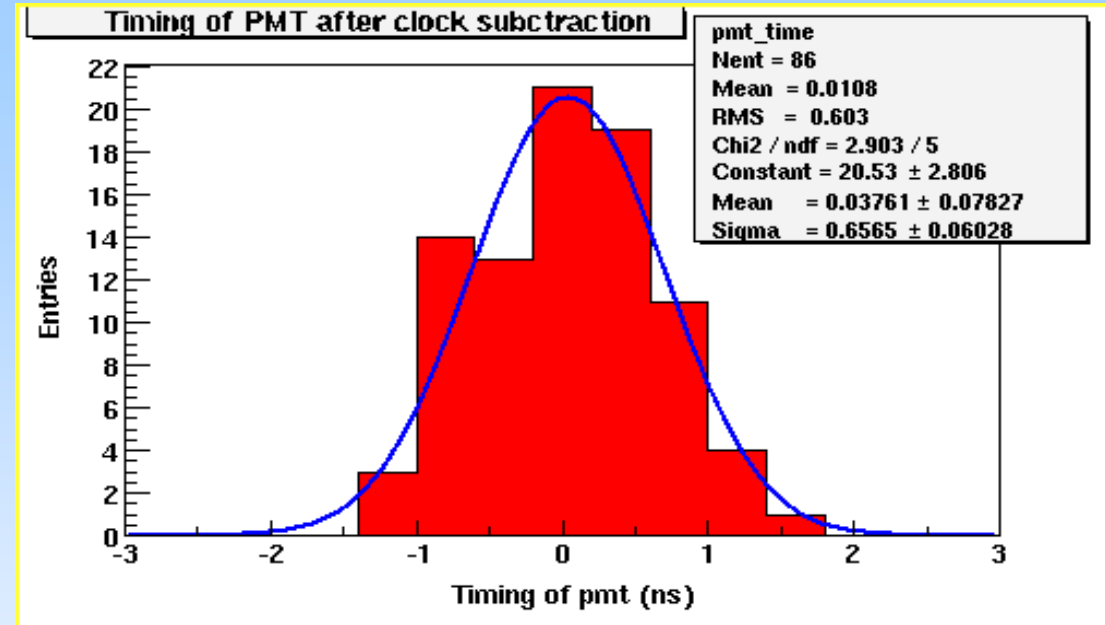

# Dynamic Range.

**Npe/GeV improves over the years due to the instrumentation experience.**

**Current plan is to set PMT gains to 1.2pC/GeV of em energy at 90 degrees.**

This will require setting HVs down by (10-40)V from the nominal values -> non-linearity from PMTs rises up to 2%.

**Non-linearity can be recovered by LAS calibration or by weighting technique (less likely)**

	Module type	Tile material	Average Npe/GeV
'98	Barrel prototype	PSM	48
'00	Production barrel	PSM	61
'01	Two production extended barrels	PSM <b>BASF</b>	63 <b>70</b>
'06	Re-thinking all the TB data		75

Dynamic Range = 1.52GeV/cell (had scale)

**Proposal to enhance the dynamic range by recovering saturation.**

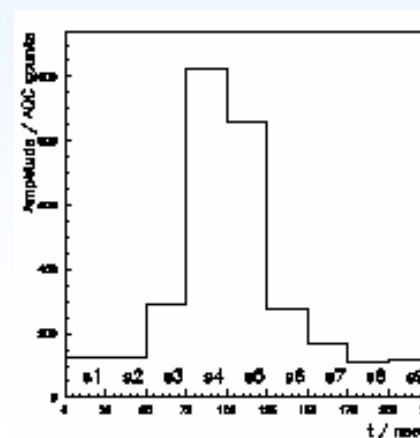
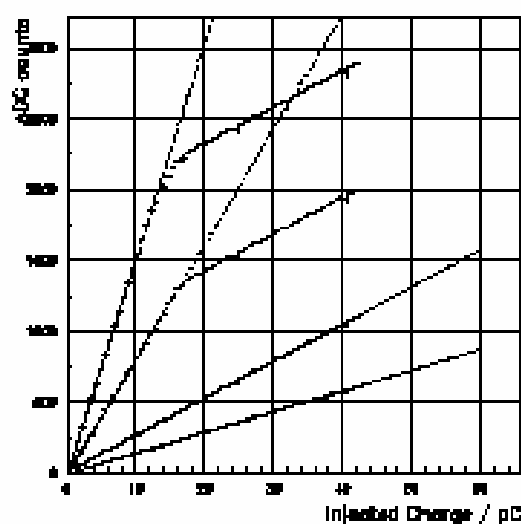
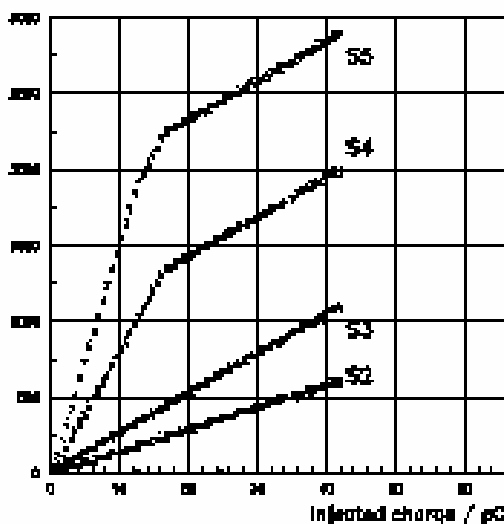

# Calibration Strategy.

## Jets in-situ calibration

To correct for detector effects

**non-linearity from non-compensation**, longitudinal leakage, pmts,  
**energy lost in the dead material**, (3-13)% depending on  $\eta$ ,  
**noise from min bias and electronics**, **magnetic field effects**, finite **granularity**  
depending on physics goals may go deeper into fragmentation, IRS, FRS ...

Recovery methods:

Weighting Techniques (H1), Energy flow method (using tracker information)

Golden channels:

**Z/ $\gamma$ +jet Pt balance**

with 10fb of data may reach 1% level  
in jet E calibration and 1% linearity.

**t- $\rightarrow$ W- $\rightarrow$ jj**

with 10fb of data may reach 2% level  
in jet E calibration and 2% linearity.

**E/Pt for a single hadron** (usually coming from  $\tau$ )

with 10fb of data (320k signal evts)  
may reach few% level in jet E calibration.

Concerns

limited statistics and HUGE number of weights (usually both Energy and  $\eta$  dependent)  
analysis usually assumes no tails in Energy measurements.

Requirements from the detector:

(5-10)% accuracy on EM scale after transporting TB calibration to the ATLAS, stability.

# Extended Barrel, Side C

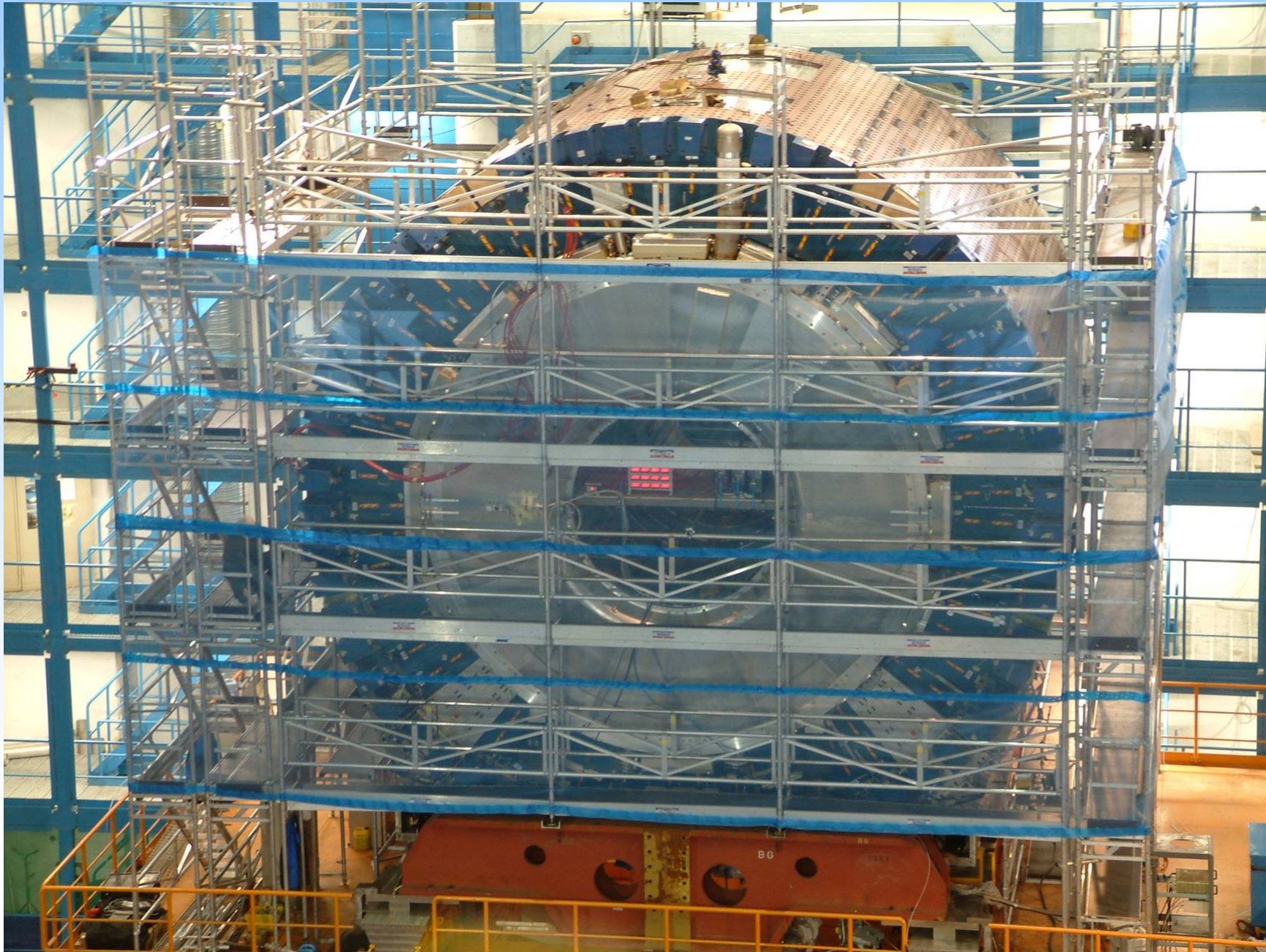

# PMT

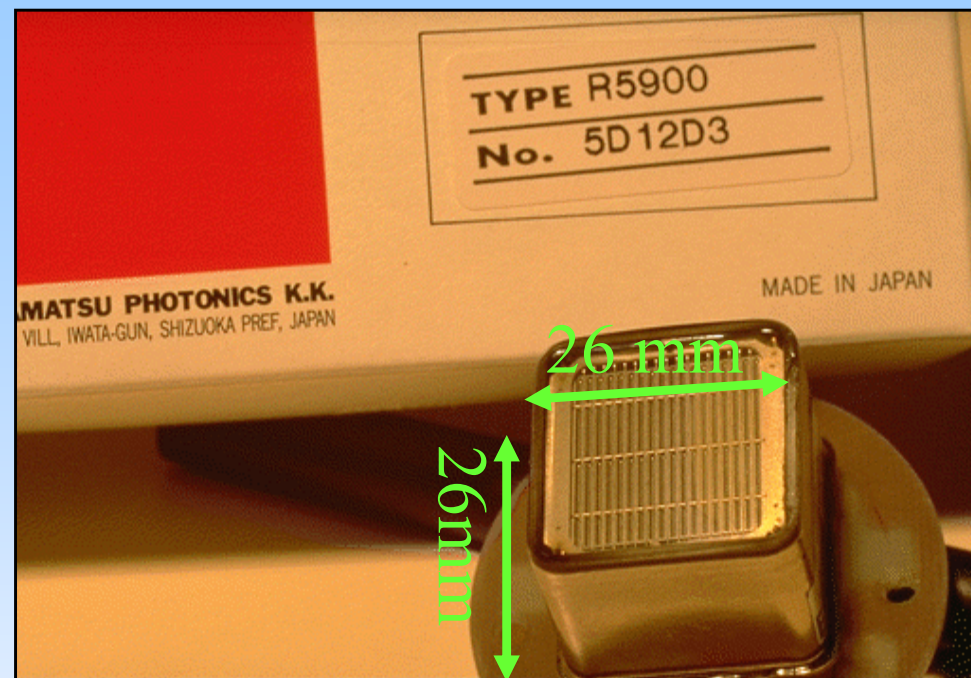
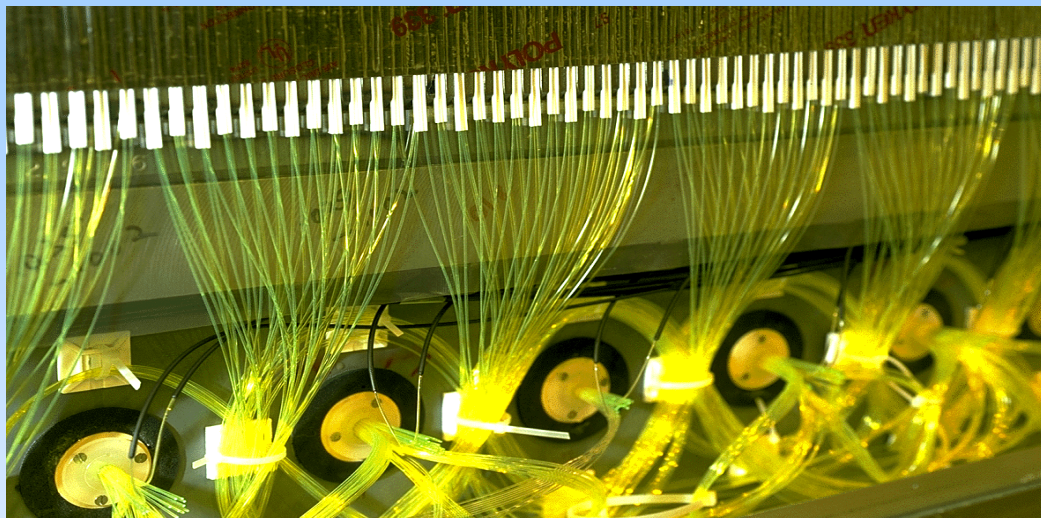

Tile+PMT ~ 75 pe/GeV (mu scale)  
 Photocathode 18x18 mm<sup>2</sup> (bialkali)  
 300 to 650 nm, max @ 420nm  
 8 dynodes  
 Dark current ~ 100pA@680V  
 $\tau_{\uparrow}$  1.4 ns, width 3.4ns,  $\tau_{\downarrow}$  3.3ns (Rms 0.3ns)  
 Small sensitivity to B & T (0.25%/°C)

3 steps of tests:  
 PMT 'alone', PMT+divider, PMT+divider+3in1

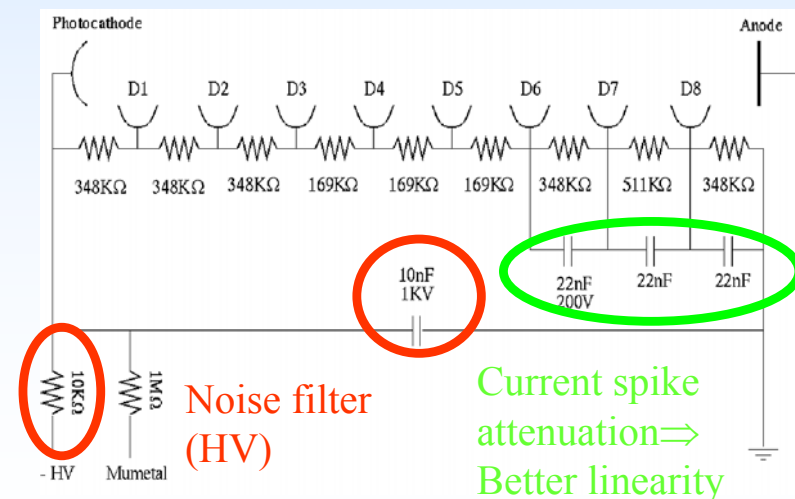



# 3-in-1 Card Schematic

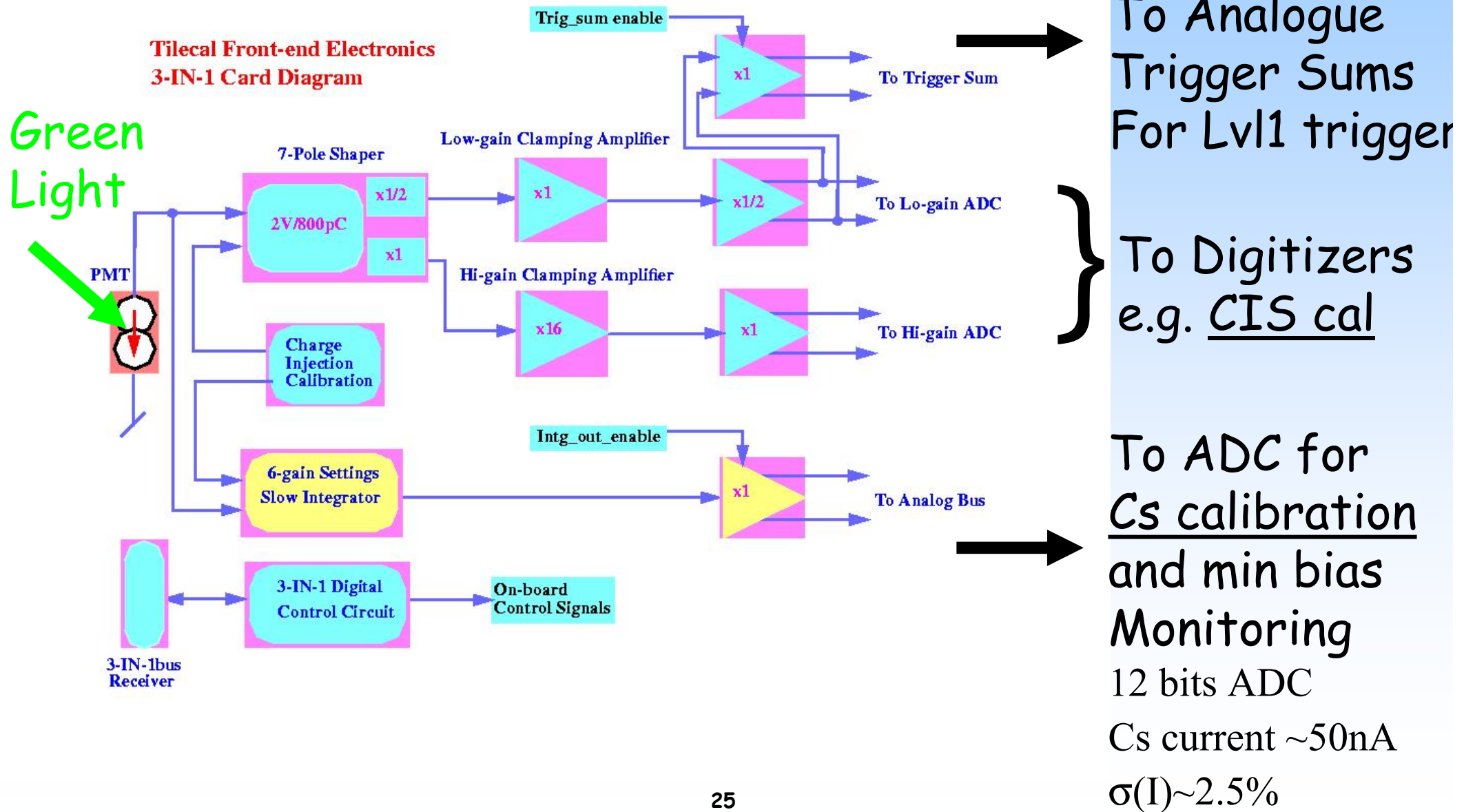

# HV Distribution System

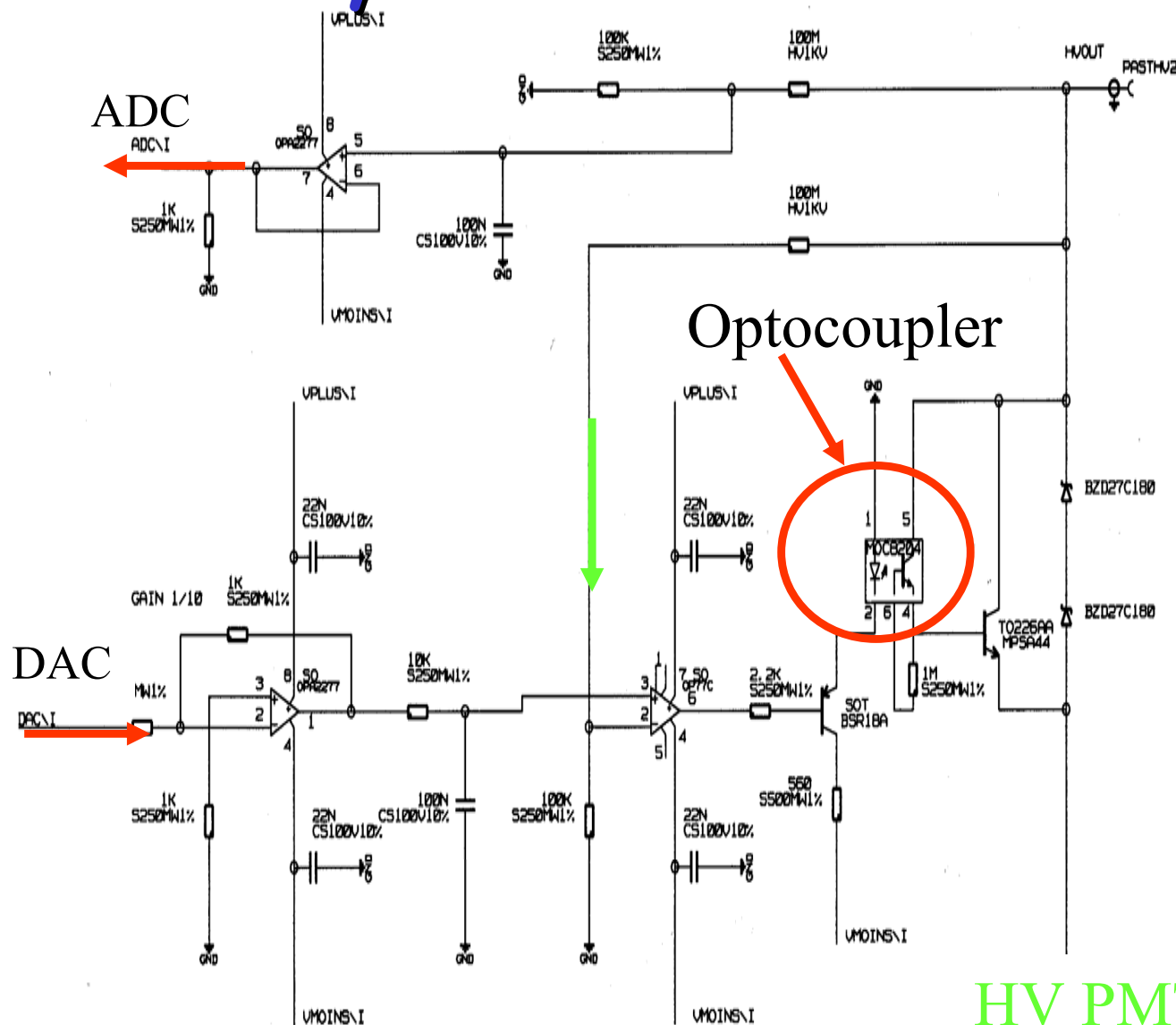
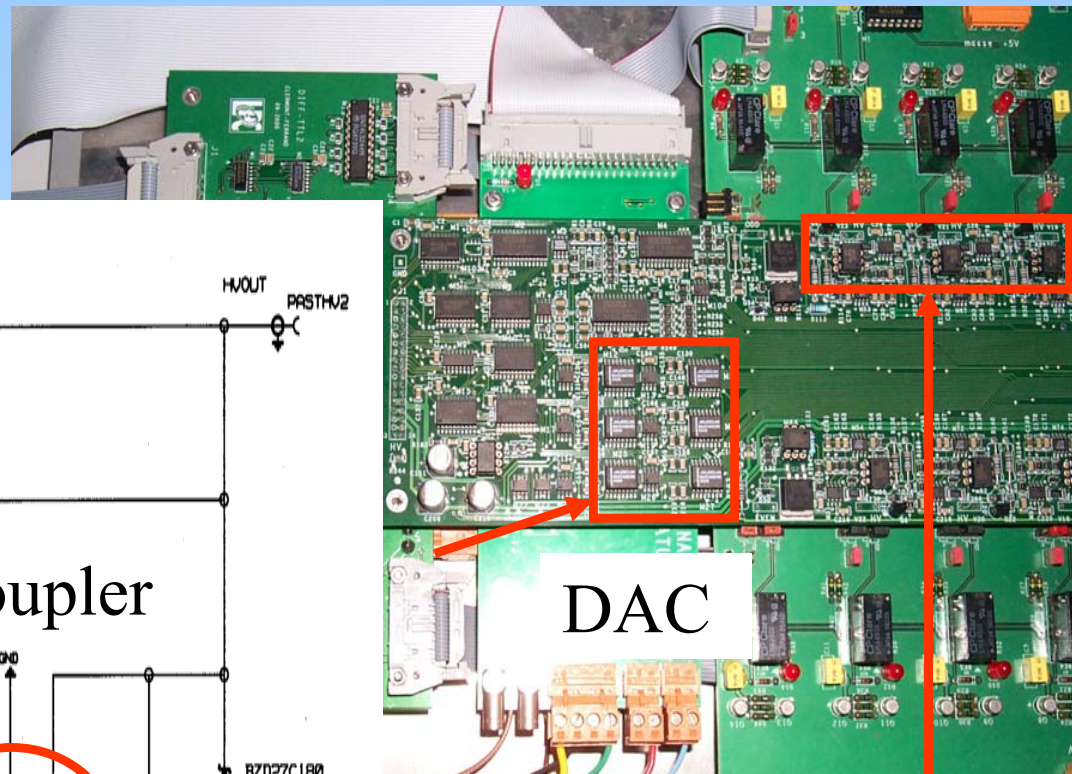

Regulation loops:  
HV @0.4V  
 $\equiv G_{PMT} @0.5\%$

Power diss. ~35W

HV PMT

All components certified in the Institutes, then

Mechanical assembly

Electronics assembly

Debugging Willy (5 min)

Short term test (1 hour)

Long term test (> 12 hours)

Insertion

MobiDICK (5 min)

New tests: Stand-Alone/ MobiDick

Step 1: Fixed Test Bench

Clermont-Fd

CERN

Step 2: Portable Test Bench

Step 3

Cooling tests: over pressure (2.5 bars)  
under pressure (0.5 bar)

Electrical tests (Grounding, Temp. Probe)  
Full cross-check of 2 operators (in 3 steps)

Everything including Cooling, except HV on  
Including reprogramming of Interface  
Repeated up to zero default

Everything, including HV<sub>Nom</sub> loading  
Back to Willy if failure

Pulsed LED with HV on (Stability test)  
Back to Willy if failure

Control of all LVs  
Now use of sense lines

Everything including Cooling  
and including HV on (24/12 V)  
Repeated up to zero default

Additional tests later  
... new repairs can be required!