



O. Napoly, CEA-Saclay, Irfu/SACM

- Cavity production status
- Cryomodule production status
- Module performance
- Conclusions



1 + 100 accelerator modules

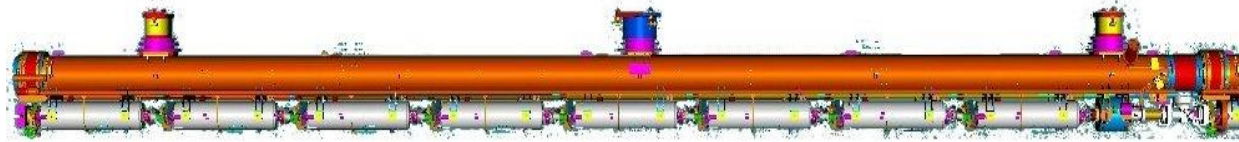

808 accelerating cavities  
1.3 GHz / 23.6 MV/m /  $10^{10}$



25 RF stations  
5.2 MW each

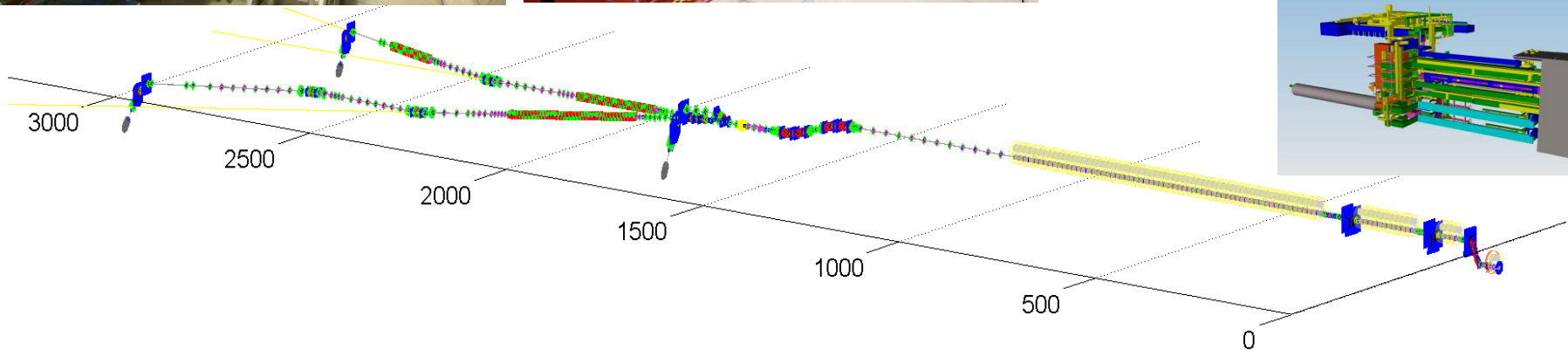
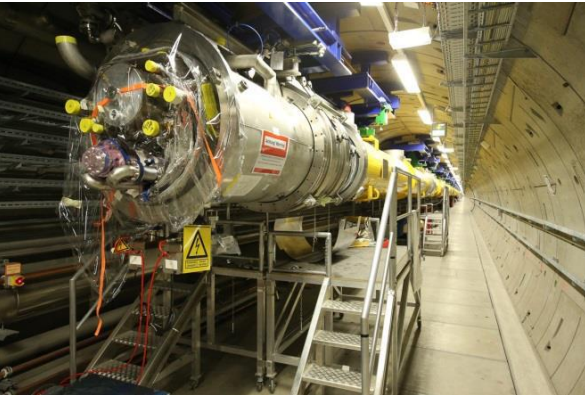
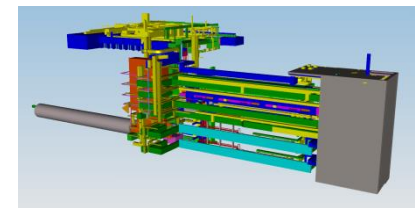

- Mechanical production (nearly) finished
- Last cavities expected in Oct 2015 at DESY
- Delivered: ~785 cavities (Aug 31)
  
- Status of vertical tests analysis: **Aug 01, 2015** (~740 cavities)
- Analysis of vertical acceptance tests includes
  - Series Cavities
  - ILC “HiGrade”-Cavities (w/o He-tank; QC)
  - NO infrastructure commissioning tests
  
- Stable average vertical test rate ~40 tests/month
- Vertical tests to be finished end of 2015

Courtesy D. Reschke



Courtesy D. Reschke

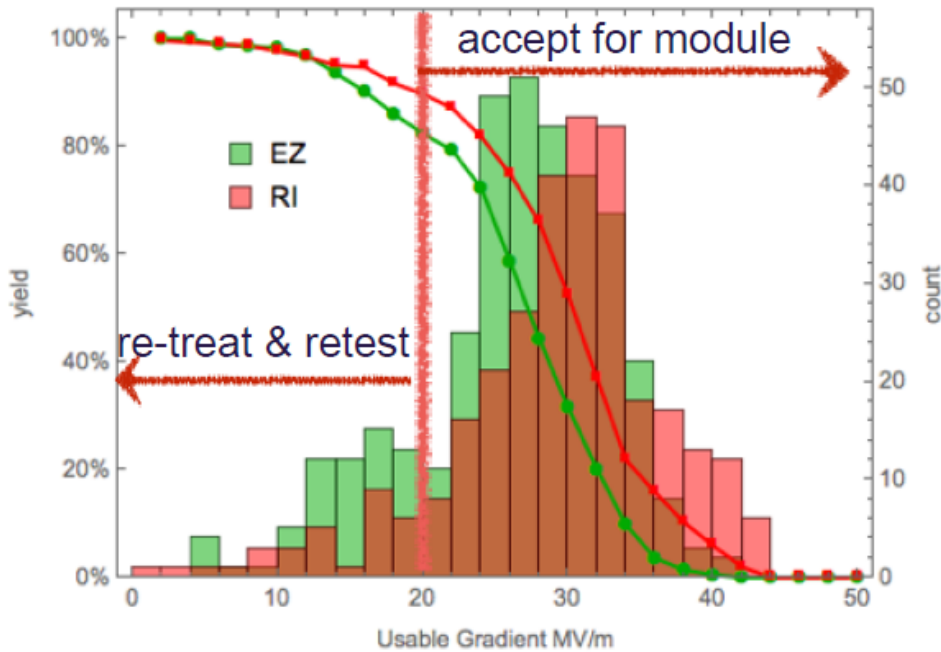

	RI	EZ	Total
Tests	303	358	661
$G_{AVG}$ (MV/m)	29.4	26.3	27.7
$G_{RMS}$ (MV/m)	7.4	6.8	7.2
yield @ 20MV/m	90%	82%	86%
yield @ 26MV/m	75%	59%	66%
yield @ 28MV/m	66%	44%	54%

## Vertical Test – min of

- Maximum gradient (quench, RF power)
  - FE limit (top/bottom X-ray)
  - $Q_0$  limit ( $= 10^{10}$ )
- Both vendors well above Spec
  - RI shows ~ 3MV/m in average more than EZ:
    - a) final EP
    - b) low gradient quenches at EZ
  - Several cavities with < 20 MV/m accepted, especially if
    - a) limitation = “bd” +
    - b) no FE

Courtesy D. Reschke

- “Missing” 75 cavities?

Not included in “as received”, because “retreatment at vendor” necessary before first RF test

- After rinsing retreatment of cavities with field emission,  $G_{AVG} > 30$  MV/m

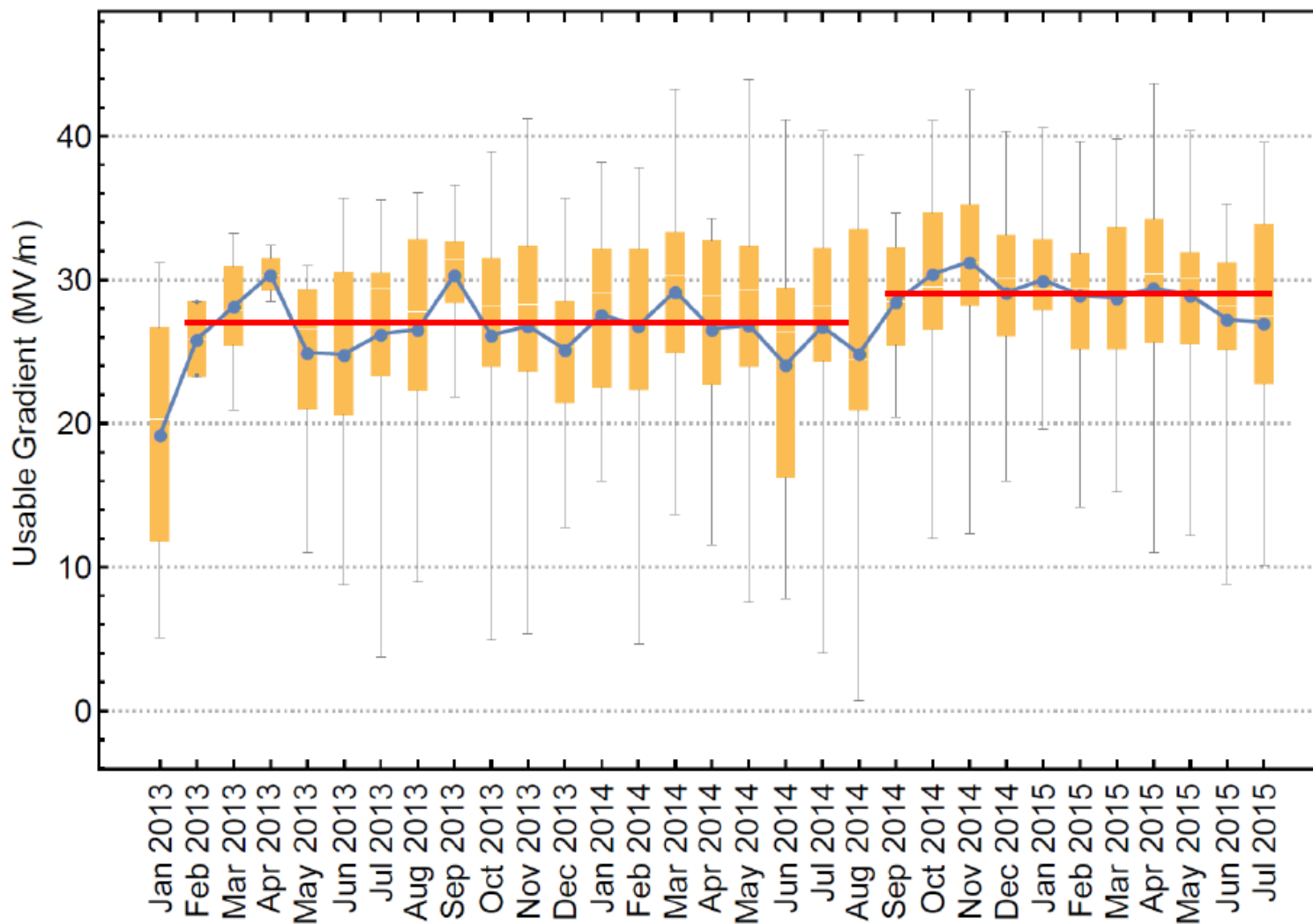

**YES!**  
Increased Usable Gradient

Courtesy D. Reschke

**CEA deliverable to European XFEL:**  
**assembly of 103 accelerator modules**  
**on the Saclay site and with CEA\* infrastructure**

\* nine pumping systems (with mass-spectrometer) and one laser-tracker from **DESY**

\* two tuner control racks from **INFN**



**Workforce by an industrial contractor Alsyom:**

→ **Quantity production goal: 1 module / week**

→ **Quality performance goal:  $E_{\text{acc}} > 23,6$  MV/m**

⇒ **Global goal:  $V_{\text{acc}} > 196$  MV per week**



**CEA deliverable to European XFEL:**

**assembly of 103 accelerator modules**

**on the Saclay site and with CEA\* infrastructure**

\* nine pumping systems (with mass-spectrometer) and **DESY** tracker from **DESY**

\* two tuner components from **INFN**

**ILC = 2000 modules @ 35 MV/m**

**Workforce** industrial contractor **Alsyom:**

→ **Quantity production goal: 1 module / week**

→ **Quality performance goal:  $E_{acc} > 23,6$  MV/m**

⇒ **Global goal:  $V_{acc} > 196$  MV per week**

1. **Industrialization**: no company was trained and qualified for module integration, unlike for cavities manufacturing. (many years after LEP200)
2. **Schedule** : throughput of 1 CM per week or faster, for a steady production over 2 years
3. **Quality** : avoid gradient degradation, cryogenic losses, coupler mis-assembly, major misalignments, non-compliant welds, etc...
4. **Complexity** : many handover interfaces with several groups at DESY, European labs and European companies.
5. **Risk**: *Assembly is **one of several** ingredients necessary for module acceptance while it may be the **only** cause for failing RF acceptance.*

**Cryo-systems**



**Vacuum vessels**



45 from Zanon, 58 from IHEP/DESY

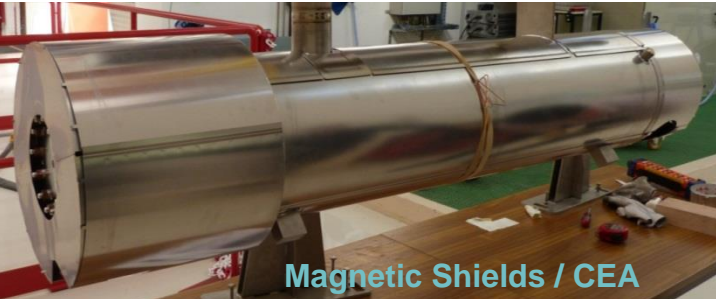

**Magnetic Shields / CEA**

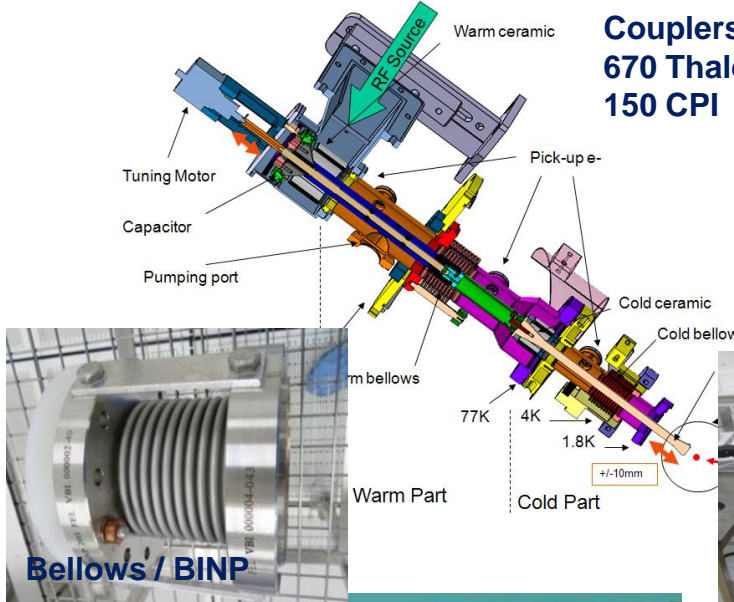

**Couplers / IN2P3**  
670 Thales-RI  
150 CPI

**Quadrupole-BPM / DESY**  
103 Magnets / Ciemat  
BPM / 72 DESY – 31 CEA  
206 Gate Valves / DESY

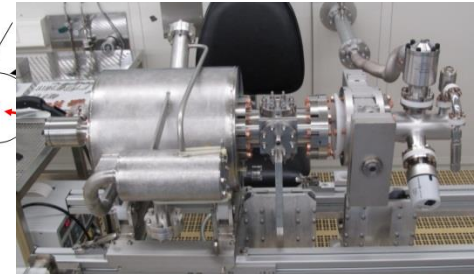

**Bellows / BINP**

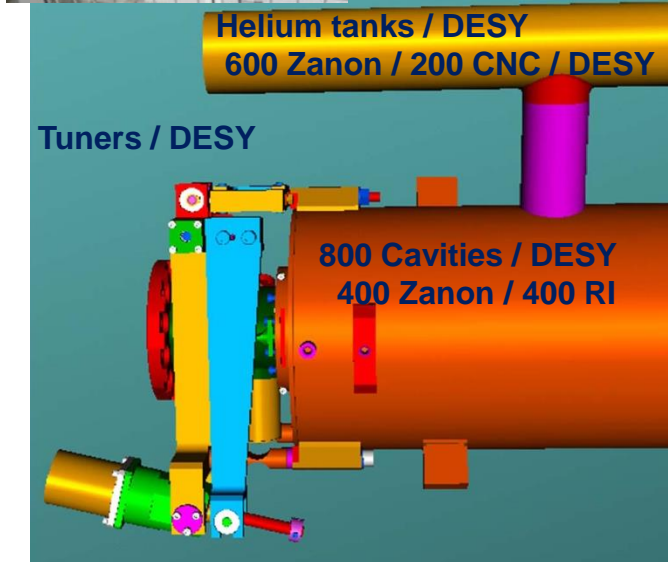

**Helium tanks / DESY**  
600 Zanon / 200 CNC / DESY

**Tuners / DESY**

800 Cavities / DESY  
400 Zanon / 400 RI

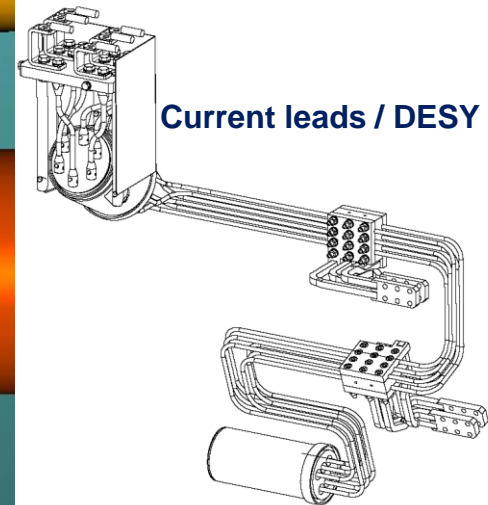

**Current leads / DESY**

Cryo-systems



Vacuum vessels



45 from Zanon, 58 from IHEP/DESY

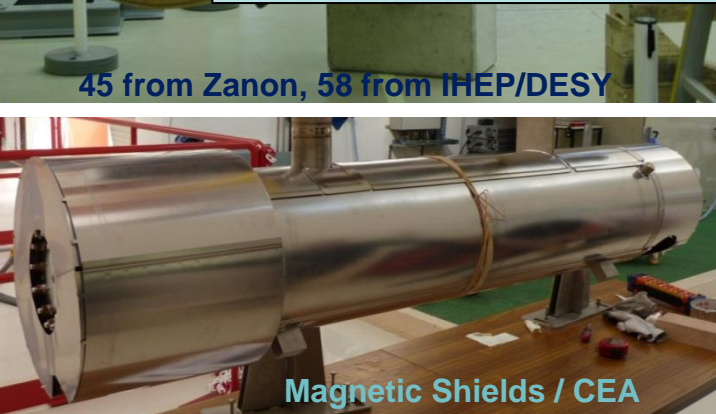

Magnetic Shields / CEA

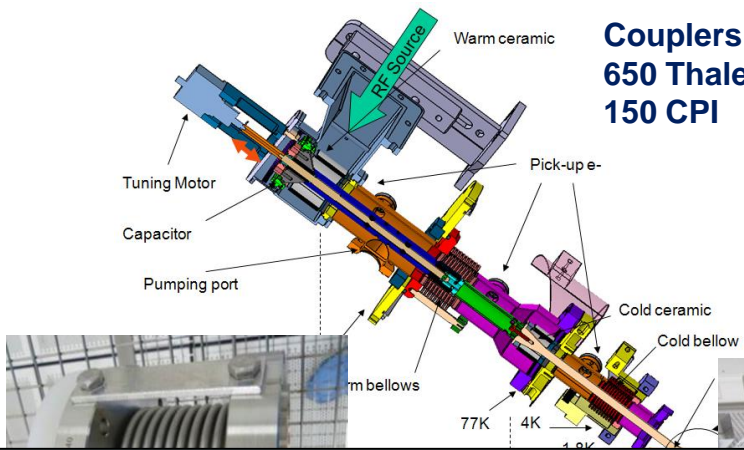

Couplers / IN2P3  
650 Thales-RI  
150 CPI

Quadrupole-BPM / DESY  
103 Magnets / Ciemat  
BPM / 72 DESY – 31 CEA  
206 Gate Valves / DESY

**There are 9 422 individual components integrated  
and over 12 400 individual parts manipulated  
per cryomodule**

800 Cavities / DESY  
400 Zanon / 400 RI



Current leads / DESY

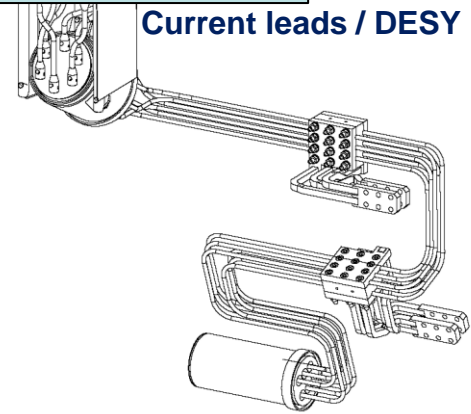



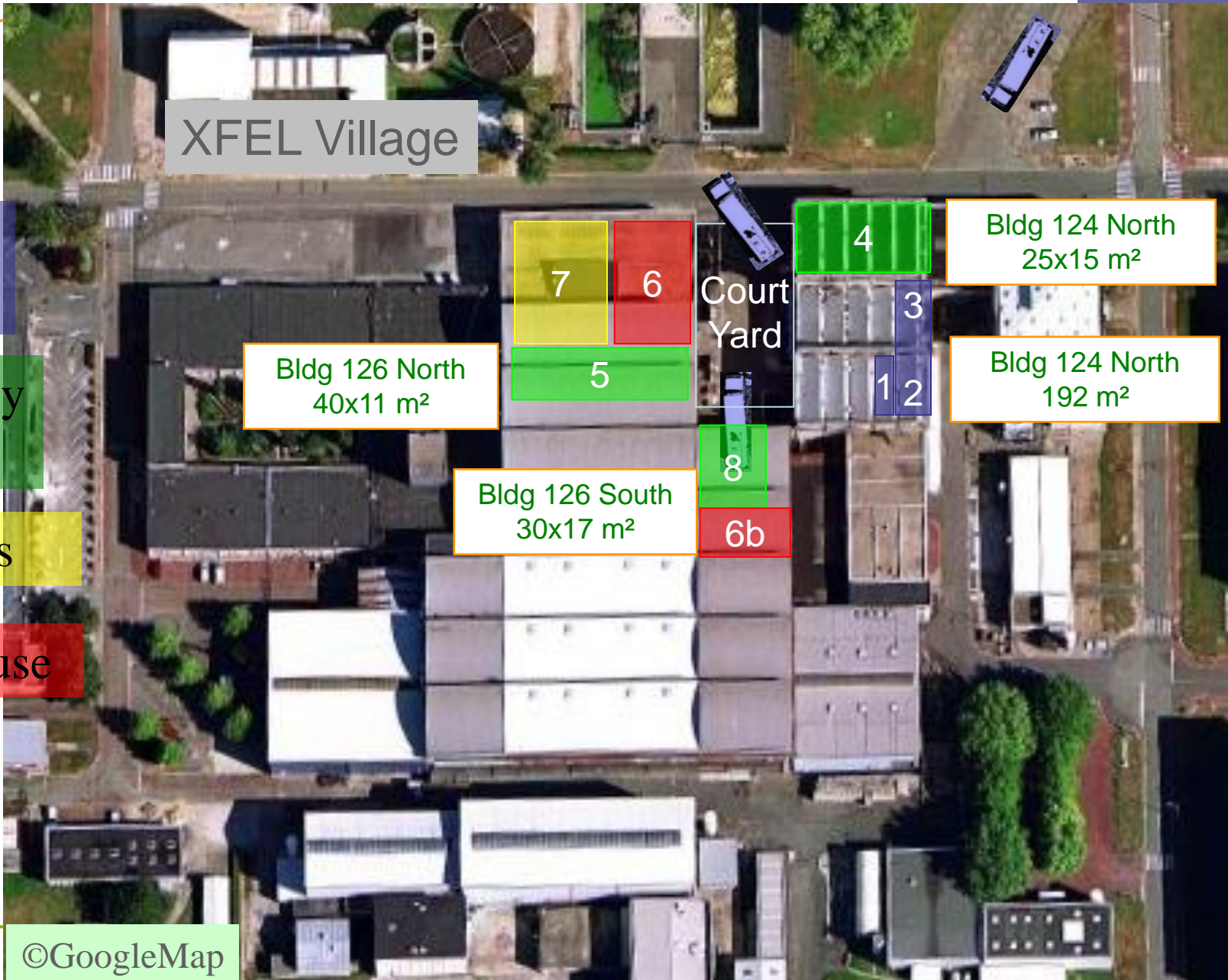

Clean  
rooms

Assembly  
halls

Offices

Warehouse

©GoogleMap

2 November 2015

LCWS 2015, Whistler

14

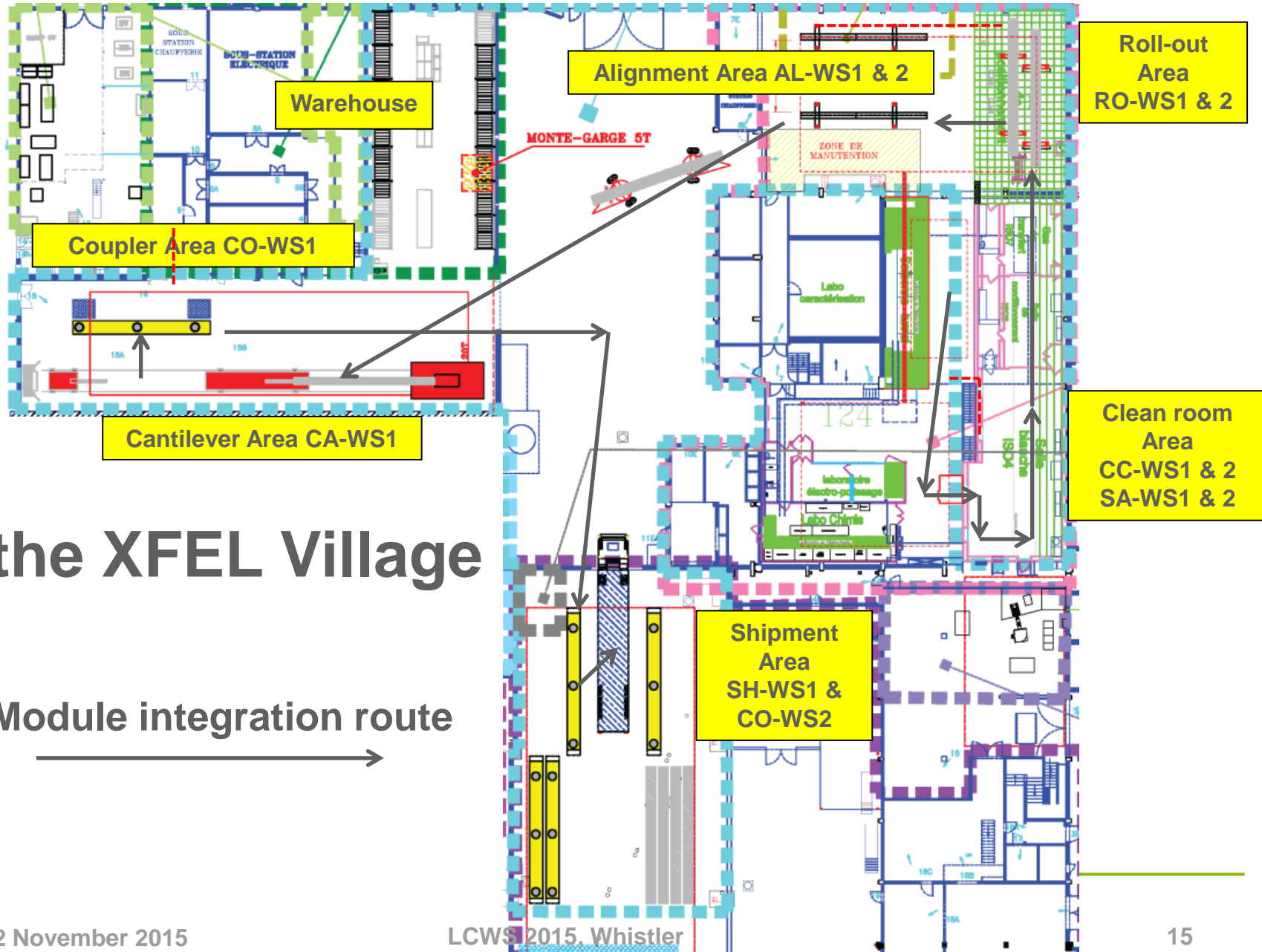

the XFEL Village

Module integration route



The breakdown of the total assembly work over 7 workstations aims at:

- balancing almost equally the occupancy of each WS,
- bringing the longest WS occupancy below 5 days (→ throughput)

**1. Clean Room Cold Coupler Area (IS04-CC-WS)\*2**

- Cold coupler assembly (x8)
- Gate valve assembly
- Leak check of cavity-coupler connection (+ RGA)

**2. Clean Room String Assembly Area (ISO4-SA-WS)\*2**

- String connections (8 cavities + 1 Qpole unit)
- Leak check of string (+RGA) and N<sub>2</sub> venting

**3. Roll-out Area (RO-WS)\*2**

- 2 Ph-tube welding, NDT (VT, LT, RT)
- HOM adjustment, magnetic shielding, T-sensors
- Tuner assembly (x8), coupler 4K and 80 K shields
- Cold-mass/string connection

# module components	# parts manipulated
~ 369	>1 075
~ 789	>2 096
~ 3 990	>4 238



## 4. Alignment Area (AL-WS) \*2

- Cavity and quadrupole fine alignment (< 300 μm)
- Welding of 8 mm LHe filling line (x9) (VT, PT, LT)
- Tuner and piezo electric tests

## 5. Cantilever Area (CA-WS)\*1

- Welding of 4K-70 K shields, 4K-70 K super insulation
- Cable routing and insulation, Qpole current lead
- Insertion into vacuum vessel and cold mass alignment

## 6. Coupler Area (CO-WX)\*2

- Couplers, coupler pumping line, leak checks (x9)
- Cabling of flanges A (x8) and flange D
- Quadrupole current lead connections and welding
- Final leak check of cavity vacuum (+RGA), final pumpi

## 7. Shipment Area (SH-WS) \*2

- Control operations (RF frequency)
- End-caps closing, N2-insulation
- CEA-Alsyom “acceptance test” and loading

# module components	# parts manipulated
~ 120	>264
~ 256	>420
~ 3 702	>4 399
~209	>209
Total 9 422	Total >12 400

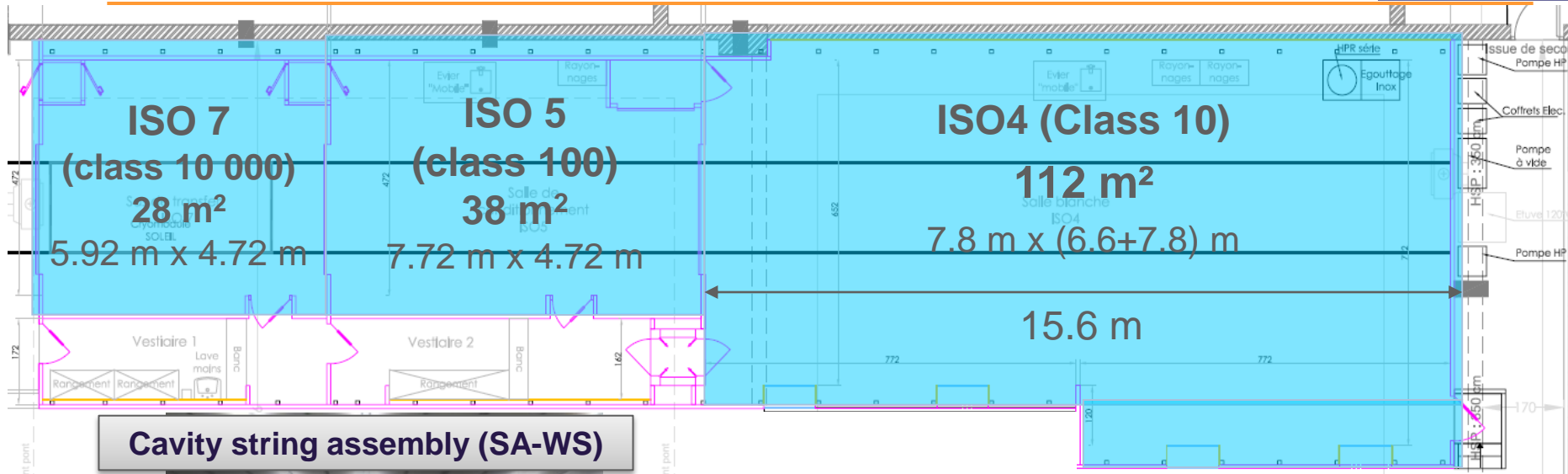

**Cavity string assembly (SA-WS)**

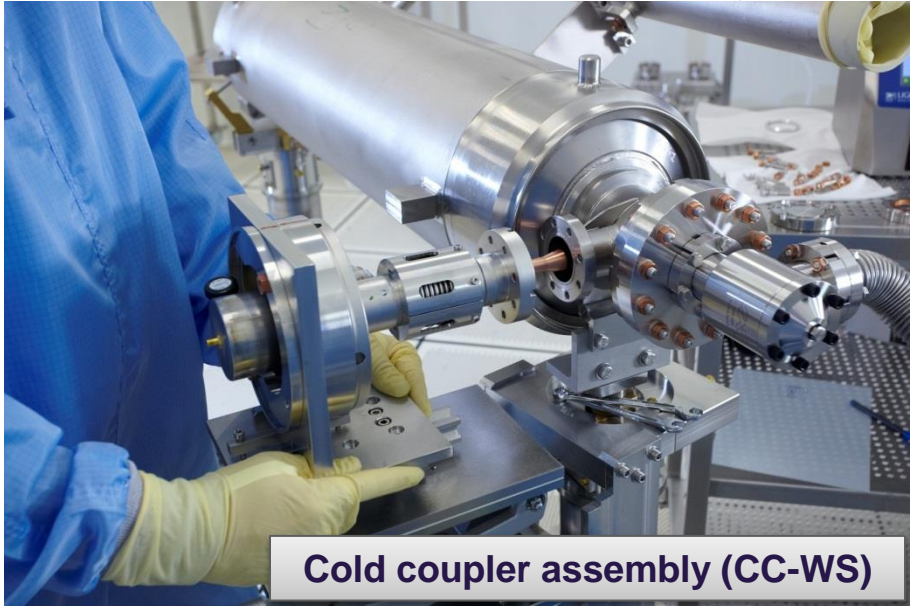

**Cold coupler assembly (CC-WS)**



**String roll-out and cold mass assembly (RO-WS)**



Roll-out (RO-WS) and Cavity alignment (AL-WS) workstations



XM1 (Cantilever) on 14/02/2014

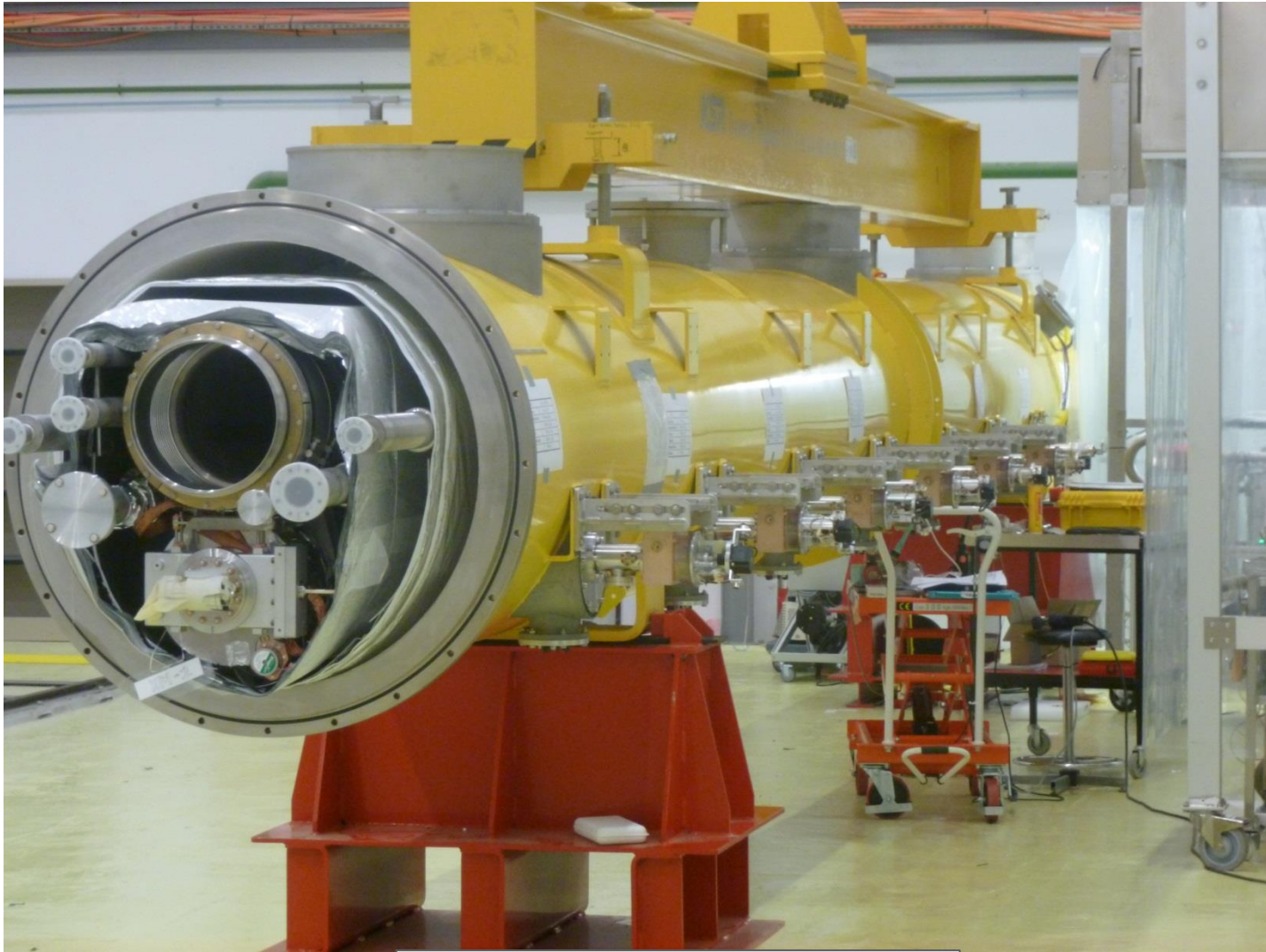

Warm coupler assembly (CO-WS)

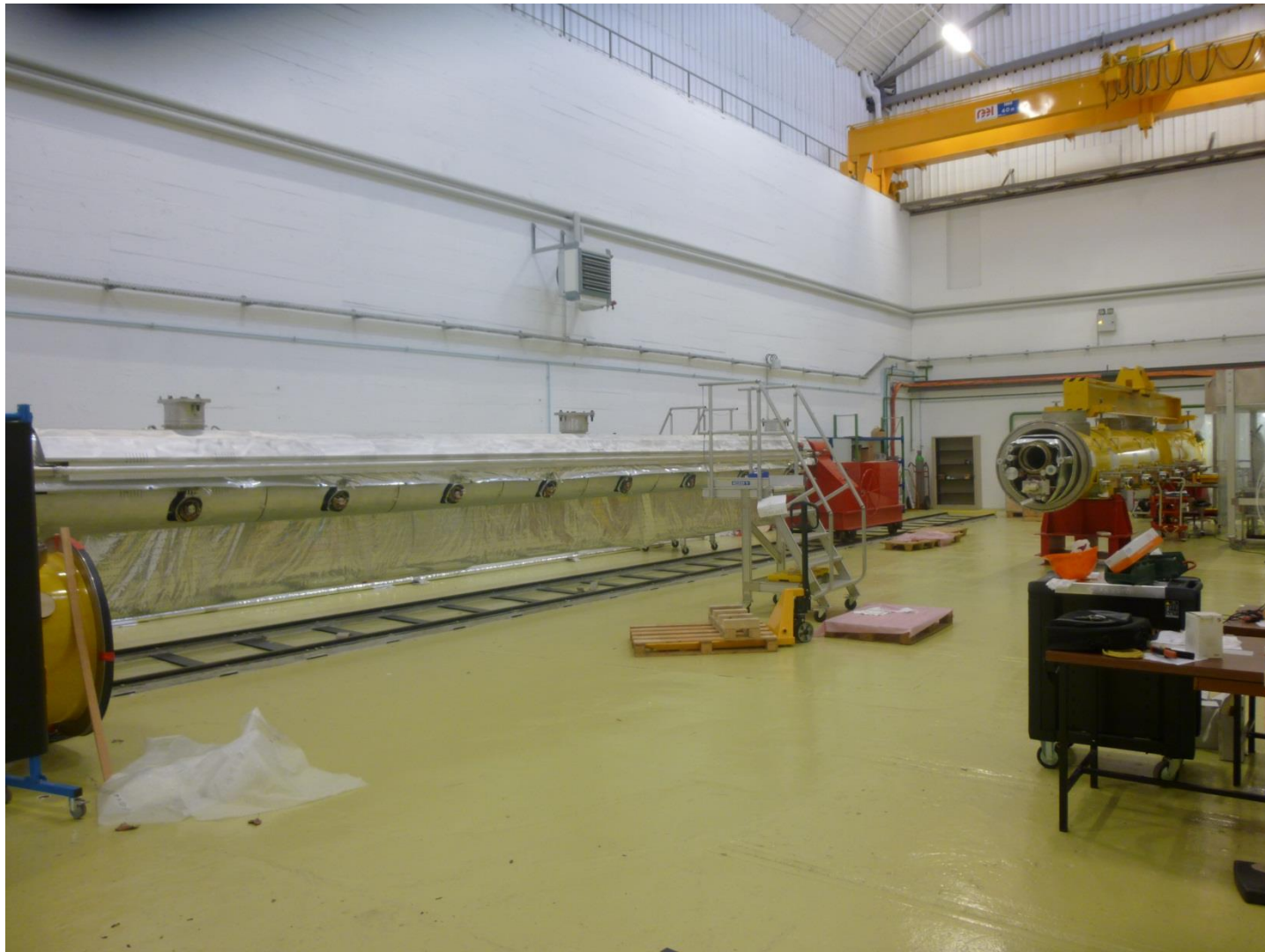

XM1 (Cantilever) and XM-1 (Warm couplers) on 14/02/2014



**Shipment (SH-WS)**



**Loading (SH-WS)**



- 5 day throughput was reached **mid-October 2014** with **XM15**  
 ⇒ the design of the Assembly Infrastructure was sound

Courtesy **ALSYOM**  
ALCEN

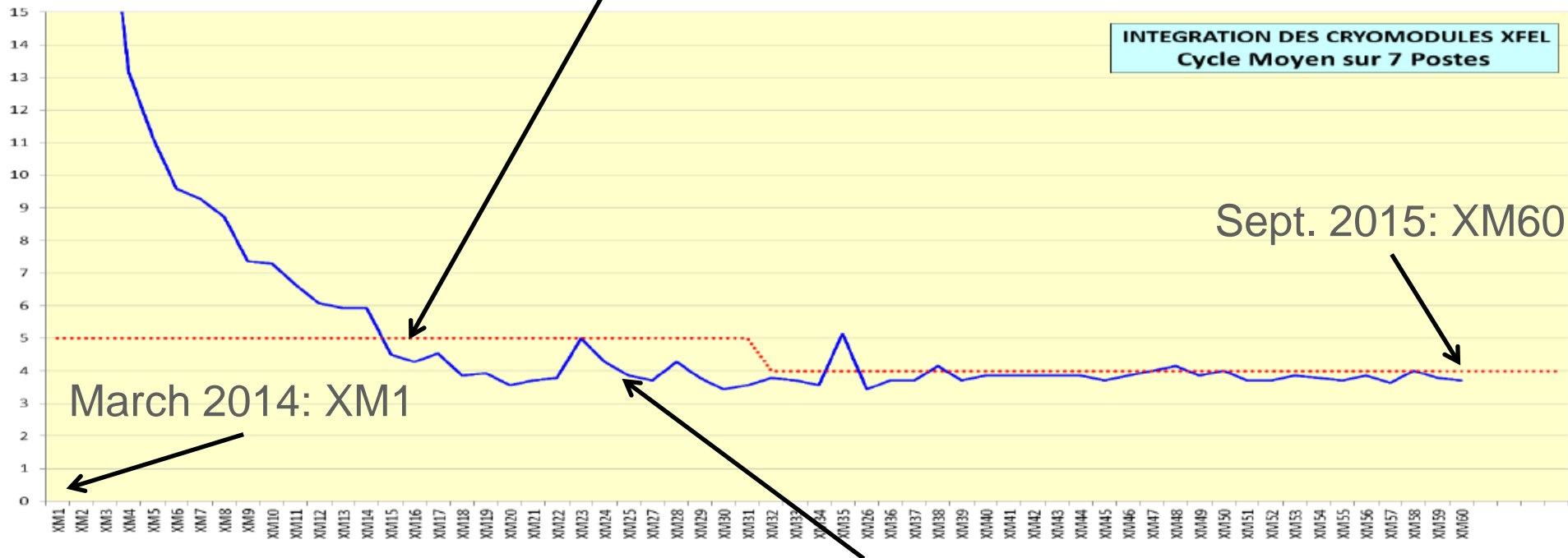

4-day throughput was reached in **January 2015** with **XM25**

This 'accelerated' rate is needed to close the XFEL tunnel mid-2016:

- XM80 to be delivered at the end of December 2015
- XM100 to be delivered at the end of April 2016

Courtesy ALSYOM

ALCEN

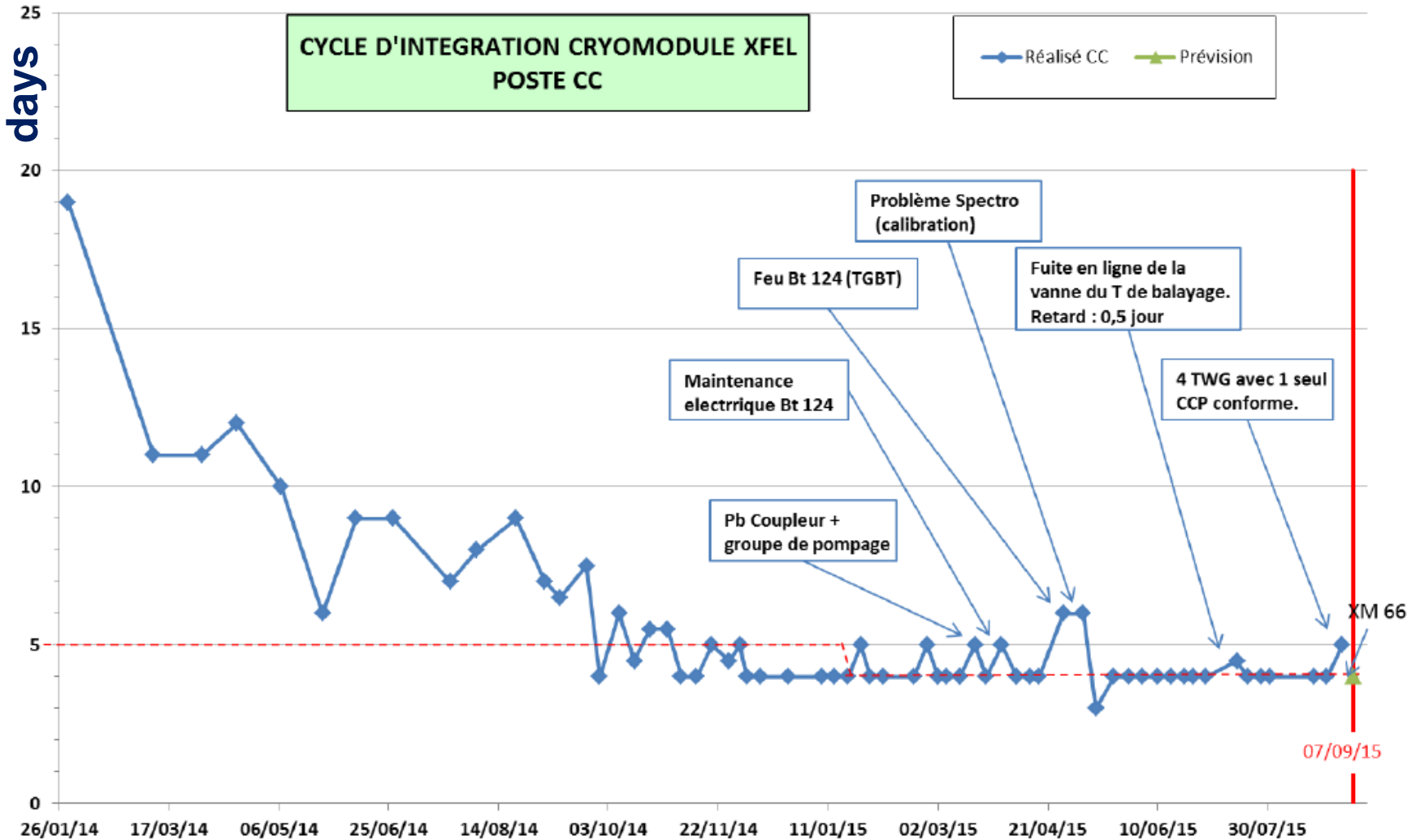

Courtesy **ALSYOM**

ALCEN

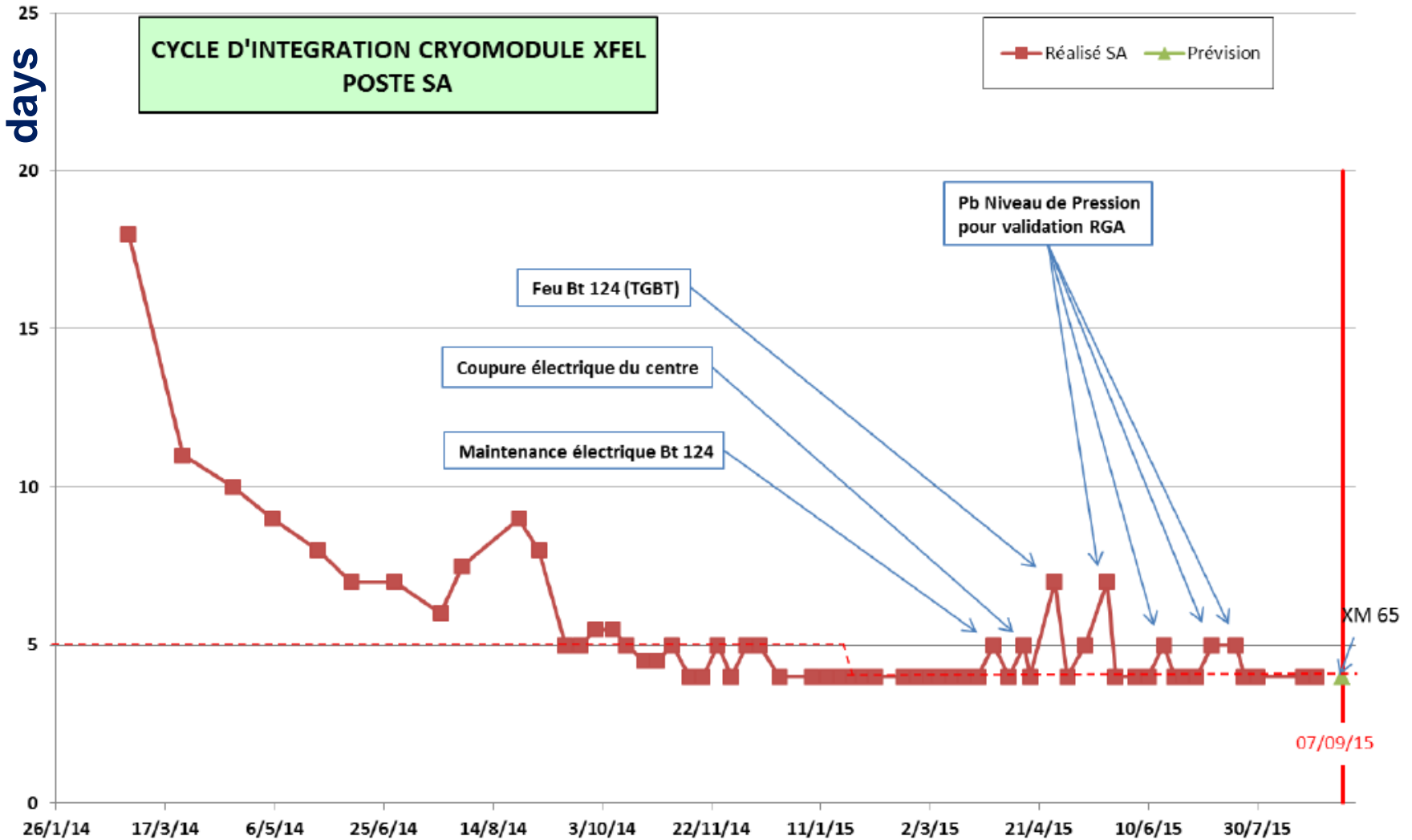

Courtesy ALSYOM

ALCEN

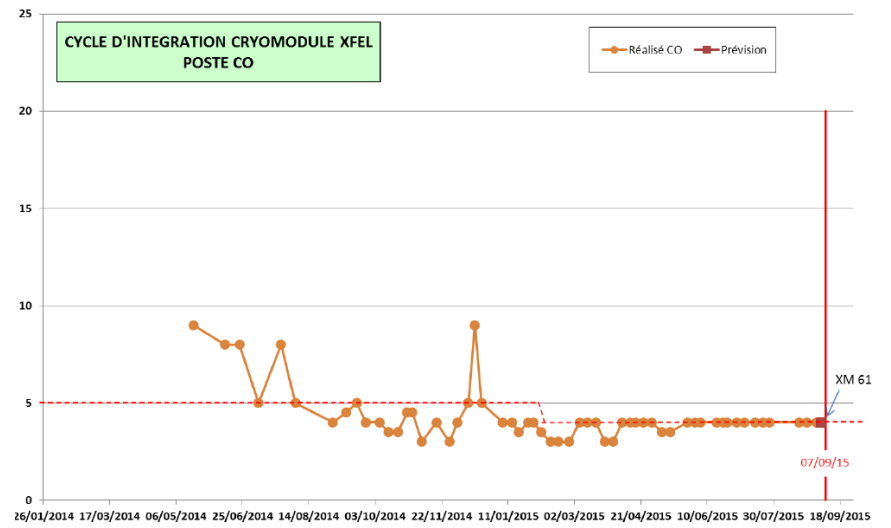
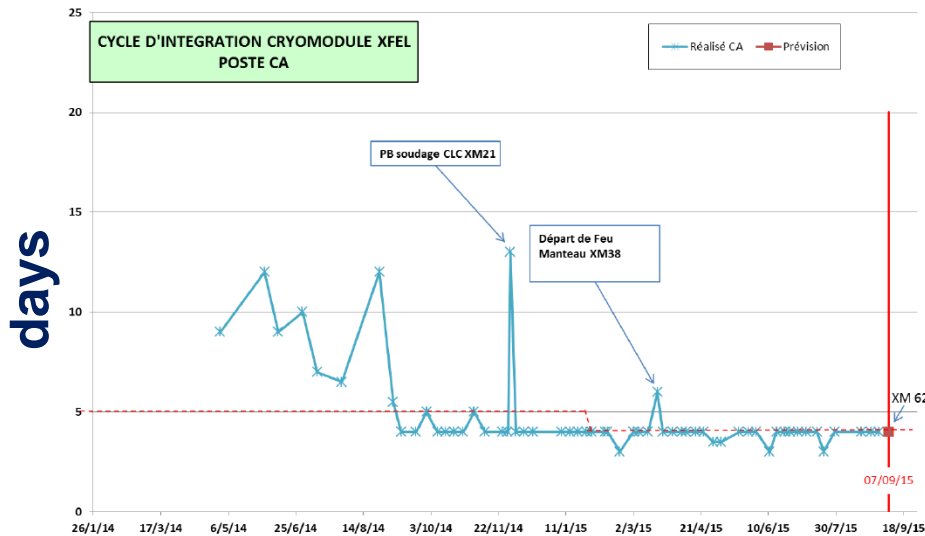
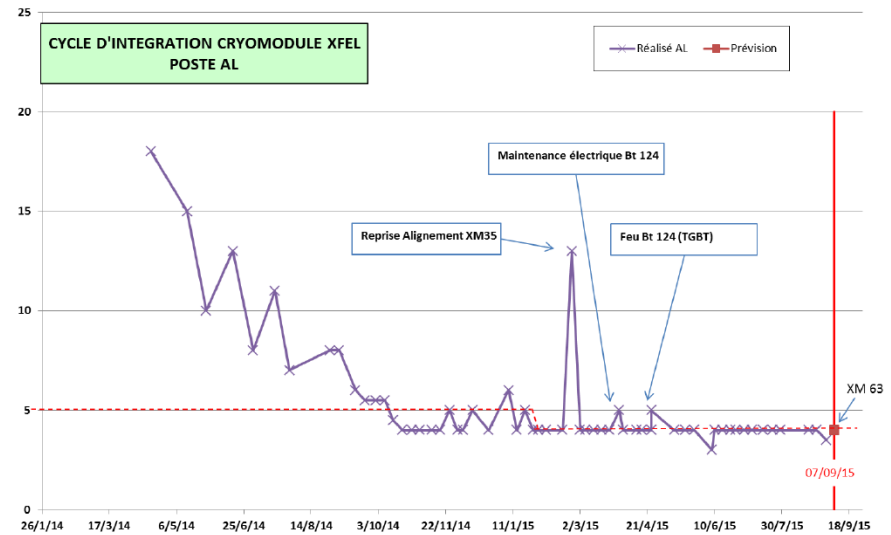
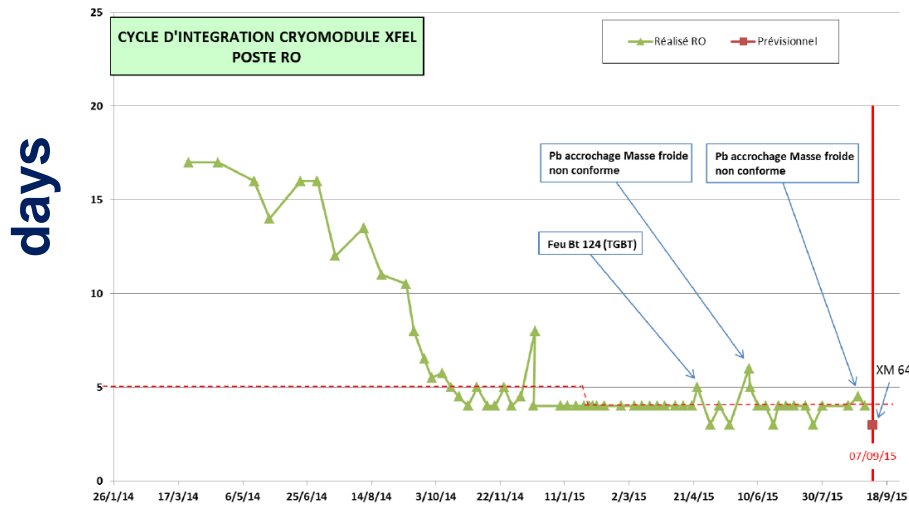

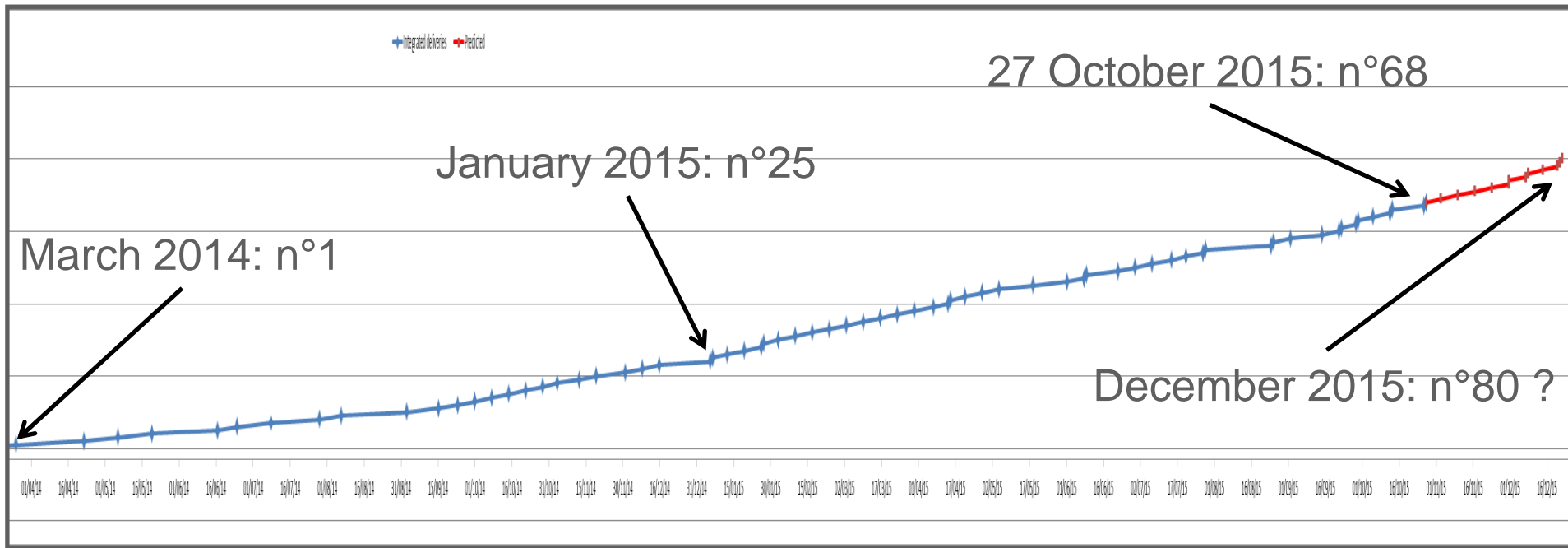

Figure: *delivery of series cryomodules, from XM1 to XM80*

- **71 modules delivered to DESY so far** (incl<sup>ing</sup> XM-3).
- Since Jan 2015, one cryomodule is delivered every 4 days (45 in total).
- The Cold Linac includes also pre-series cryomodules XM-2 and XM-1
- The assembly schedule foresees the delivery of XM100 end of April'16

Productivity gained from improvement of small tools

1) Pre-fabricated et reusable devices for the leak-check of the cavity string connections → **3 units fabricated and in use.**

2) Realization of gate valve support for its assembly on Cold-Coupler workstation:

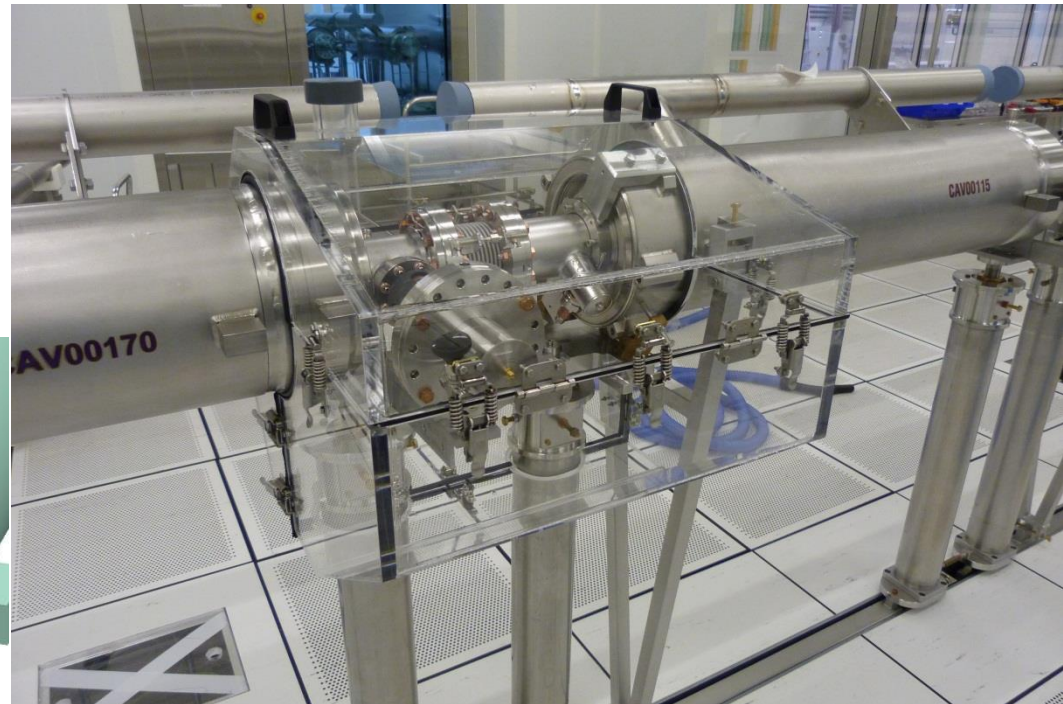

Inter-cavity connection leak-check box, including cold coupler connection, and pre-existing HOM flanges

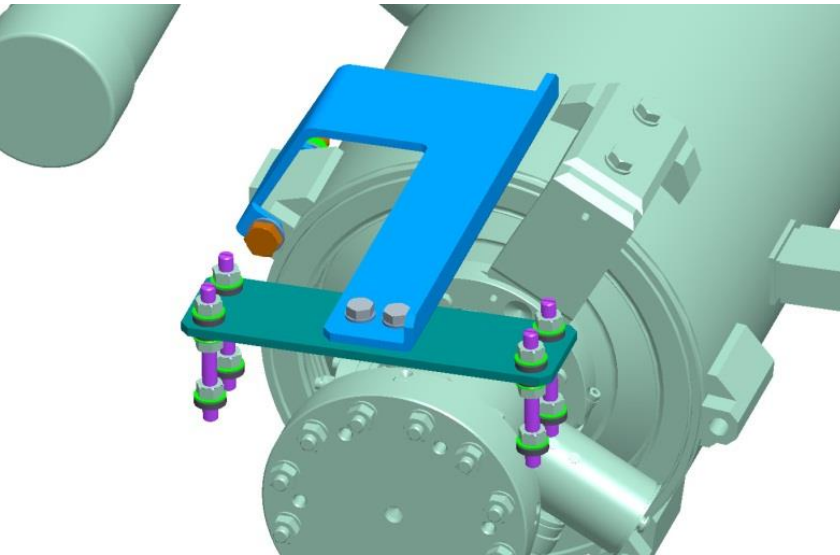



## Productivity gained from improvement of small tools

Socks used to transfer cavity string from Clean Room to Roll-out Area, suppress time-consuming cleaning of cavity posts







Acceleration of Production benefits from:

- New clean room assembly procedure: moving individual cavity venting after the leak check of the cold coupler assembly, rather than later, before the string assembly. This eliminates one connection to pumping stations for cavity venting, and one valve closing-opening cycle.  
*Tested on XM27 and implemented from XM54, with additional filters.*
- Pure Argon instead of He-Ar (50%-50%) inert gas for Titanium welding: to save the long and unpredictable time needed to pump and purge the LHe tank in order to reduce the He background enough to perform the Helium leak test (LT) by external accumulation.  
*The certification process is ongoing.*
- Reducing the impact of non-conformities, particularly imported NC.  
*More human resources have been put on incoming inspection and QC.*

Non Conformities recorded by Alsyom fall into 3 categories:

- 1) Tooling and assembly equipments (TOOLING)
- 2) Accelerator components (PRODUCT)
- 3) Assembly operations (PROCESS)

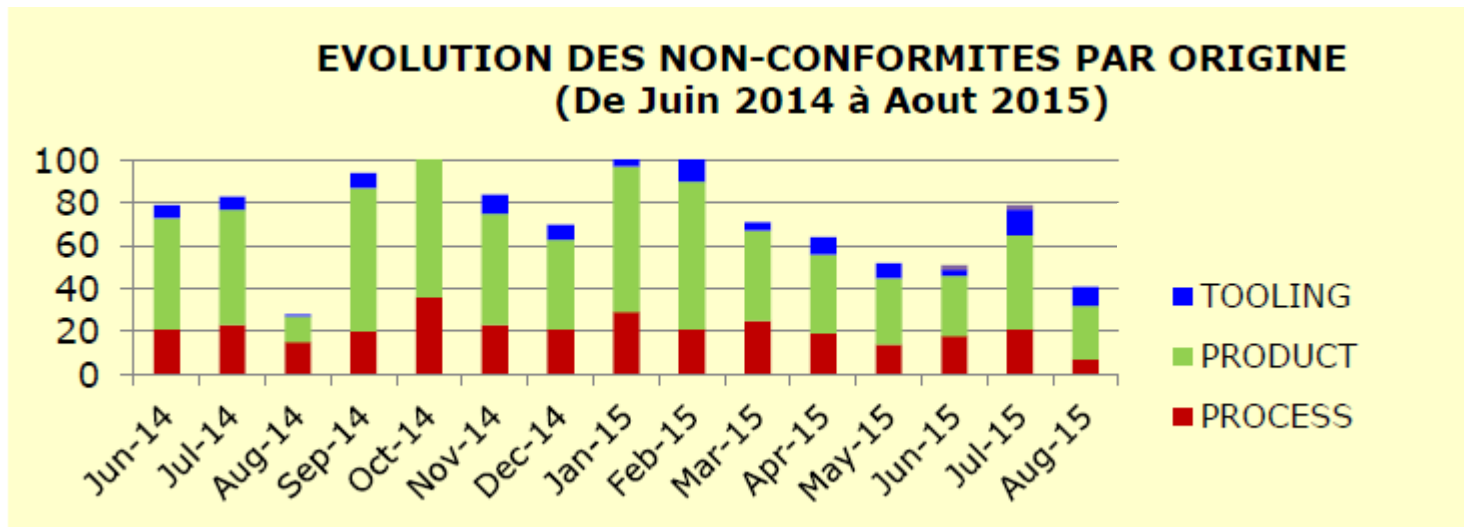

The number of Non Conformities is not going down.

But, with better and more efficient detection at incoming inspection, the impact of PRODUCT NC on the module assembly has considerably decreased, compared to when many NC were discovered 'on the fly'.



XM-3 : First pre-series module, 100 % made by CEA.  
 Module with large-grain cavities, will not go in the XFEL Tunnel

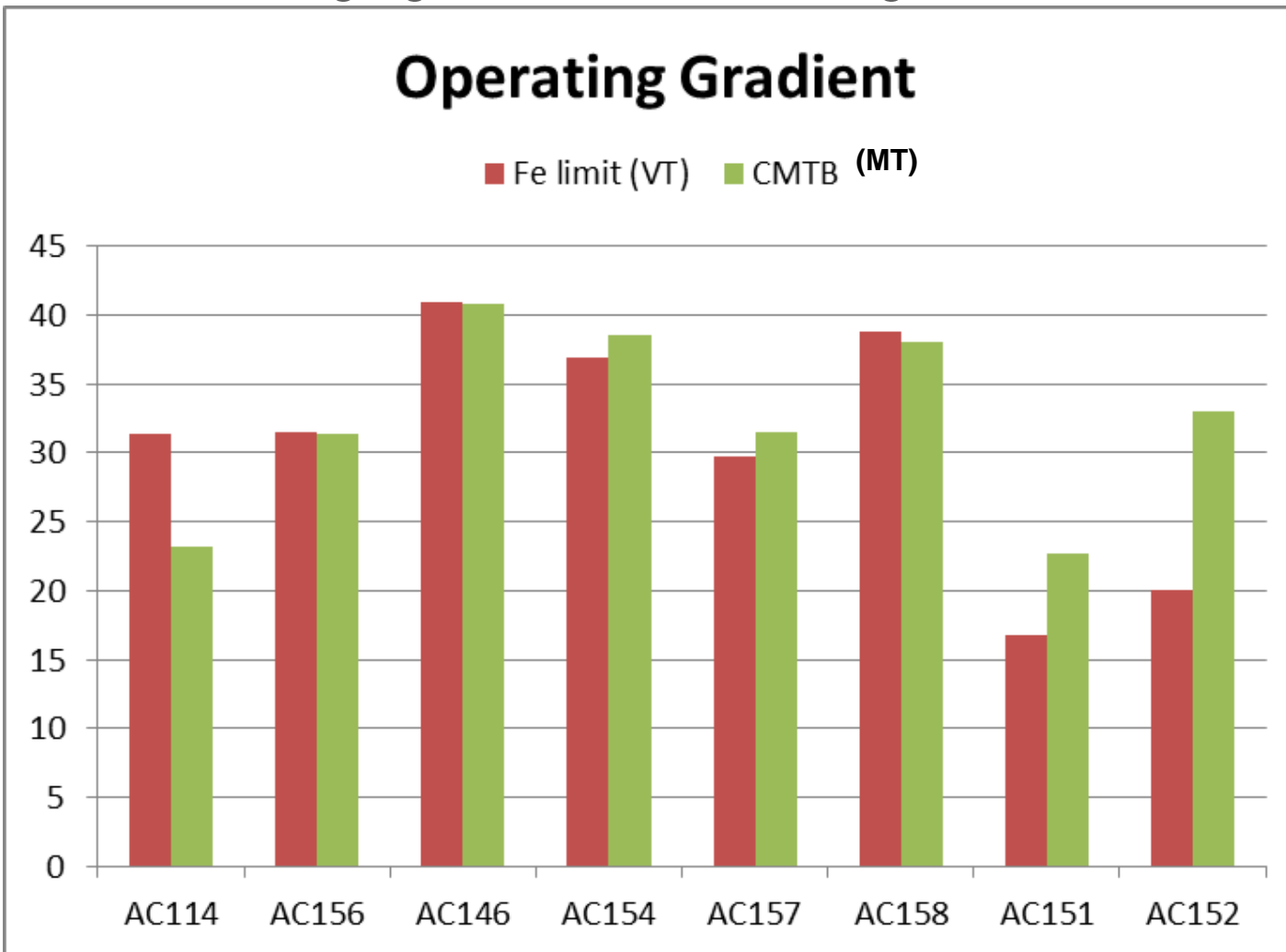

- Accelerating gradients are the most scrutinized module performance parameters, although heat loads, alignment and PED certification are entering the acceptance criteria.
- The absolute gradient is the result of the whole production chain, from the Nb sheet to the RF module test (MT). It is mostly determined by **cavity manufacturing** and **module assembly**.
- The quality of module assembly shows in the gradient difference between cavity acceptance (VT) and module acceptance (MT).
- The VT vs. MT comparison of both the ‘maximum’ and the ‘operational’ gradients is impaired by a **systematic error**:
  - Maximum gradients depend on 1) RF duty cycle, 2) cooling conditions and, 3) magnetic environment, which are completely different from VT to MT → *mostly cavity-independent error*
  - Operational gradients depends, **in addition**, on X-Ray measurement devices which are completely different from VT to MT (although cross-calibrated) → *mostly cavity-independent error*
  - Finally,  $Q_0$  is not measured in MT: therefore the MT usable gradient could correspond to **lower** or **higher**  $Q_0$  values → *cavity-dependent error*

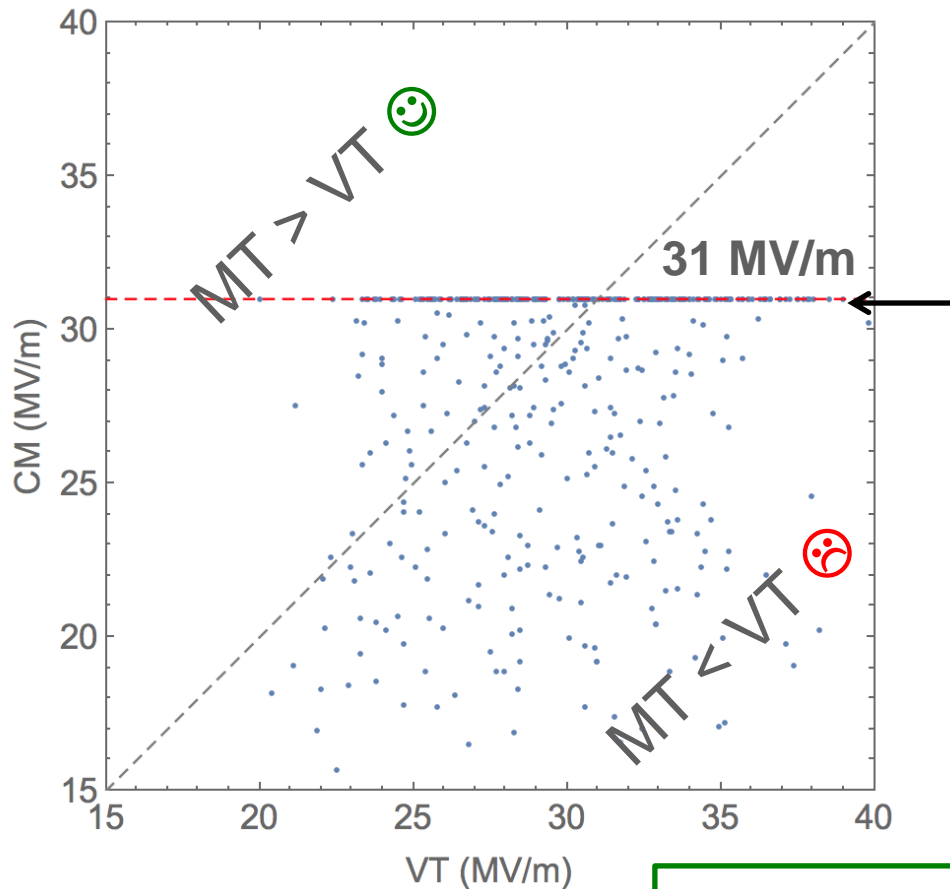

## E-XFEL Module Assembly ‘Phase Diagram’

RF Test and Linac operation limited to 31 MV/m to protect the RF distribution system

	$N_{\text{cavs}}$	Average	RMS	min	max
VT	455.	30.1	4.3	20.	43.6
MT	455.	27.4	4.6	10.5	31.

Courtesy N. Walker

Average operating gradient per cryomodule, clipping the VT results to 31 MV/m

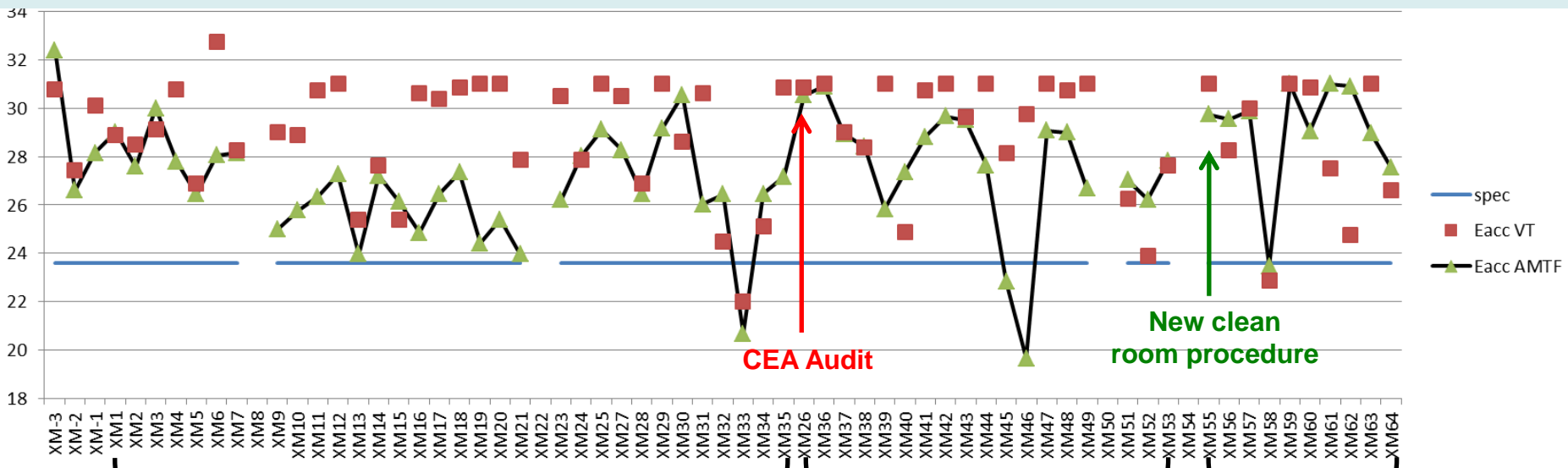

1st sample of 32 series CM  
 $\Delta E_{op} = -2.1$  MV/m

2nd sample of 18 series CM  
 $\Delta E_{op} = -1.7$  (-0.9) MV/m

last 10 series CM  
 $\Delta E_{op} = +0.7$  MV/m

- All but 2 of 59 tested modules are on XFEL specs (23.6 MV/m), 4 modules need repair.
- Average gradient is 16% above specs :  $\langle E_{acc} \rangle = 27.4$  MV/m.
- Significant gradient degradation from XM6 to XM23, while CEA and Alsylom put all their effort in achieving production goal of 1 CM/week: **an audit of string and module assembly was conducted by CEA on XM26**
- **A simplification of the clean room procedures was introduced at XM54**



## Audit Findings:

- Operators walk too fast in the clean room.
- Record the cleanliness level ( $< 10$  particles / min) reached on the angle valve before the pump connections to the cavity (CC and SA).
- Two operators are requested to connect cavity to the pumping system (CC and SA).
- Two operators are requested to position inter-cavity bellows and screw first 4 studs (SA).
- Pre-alignment of parts (coupler and cavity flanges at CC, inter-cavity bellow/cavity-coupler-side flange at SA) is requested for easy and clean assembly.
- Improvement of operator positions versus critical RF surfaces (avoid top assembly, request seated).
- Gate valve connection to pumping system procedure has been reviewed recently to ensure better cleanliness (CC).



## Observation during XM26 assembly

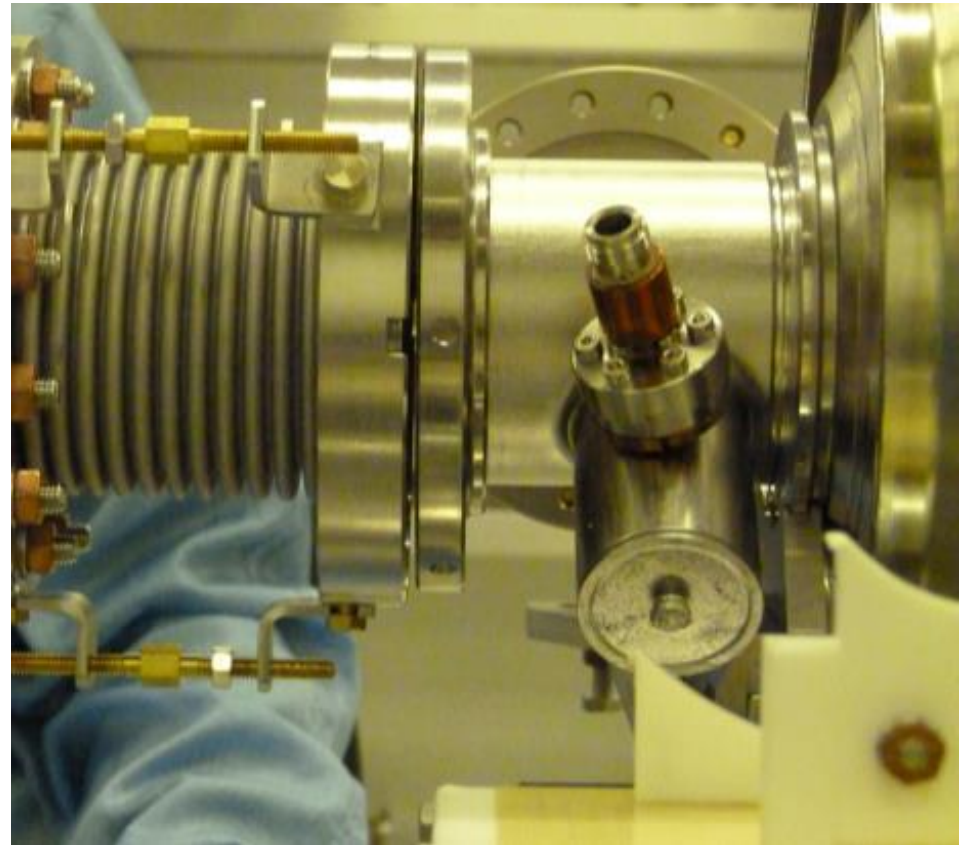

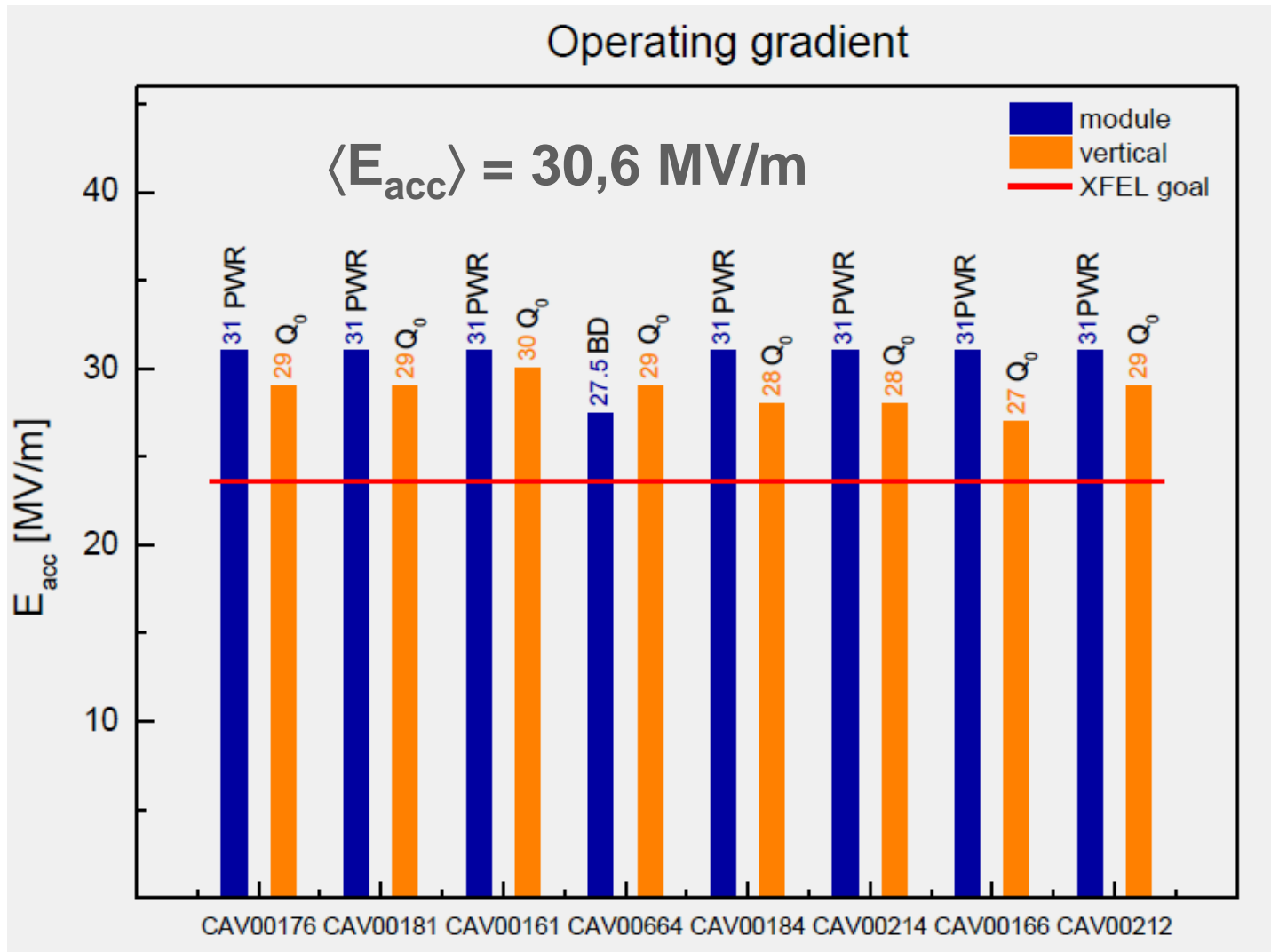

XM30 is an excellent module, though assembled before the audit

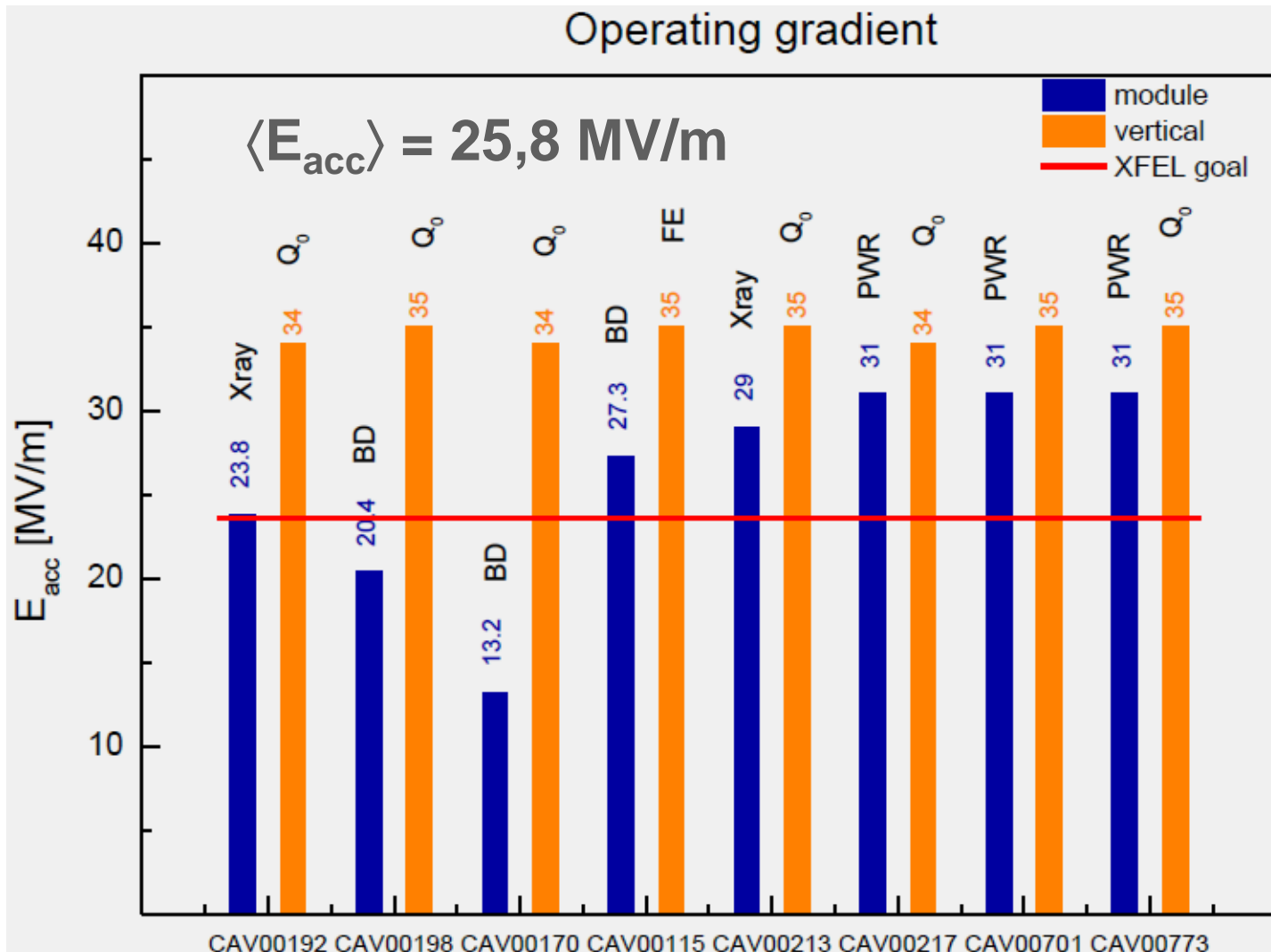

XM39 is a poorly performing module, though assembled after the audit

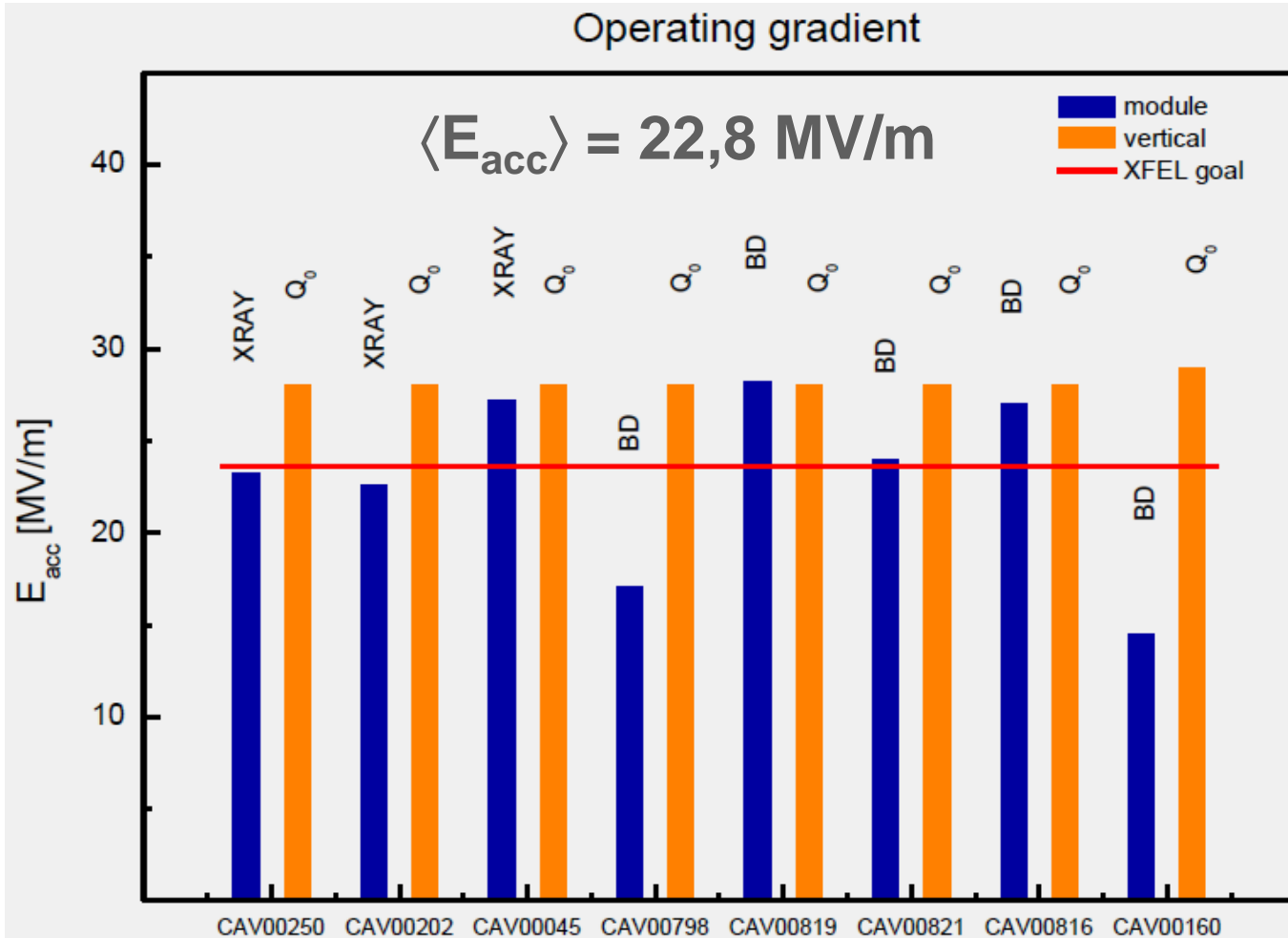

XM45 string assembly was interrupted by an **accidental electric shutdown in the clean room** while the string of 3 cavities was under N2-flushing. No good explanation for cavities 4 and 8 degradations.



$E_{acc}$  [MV]

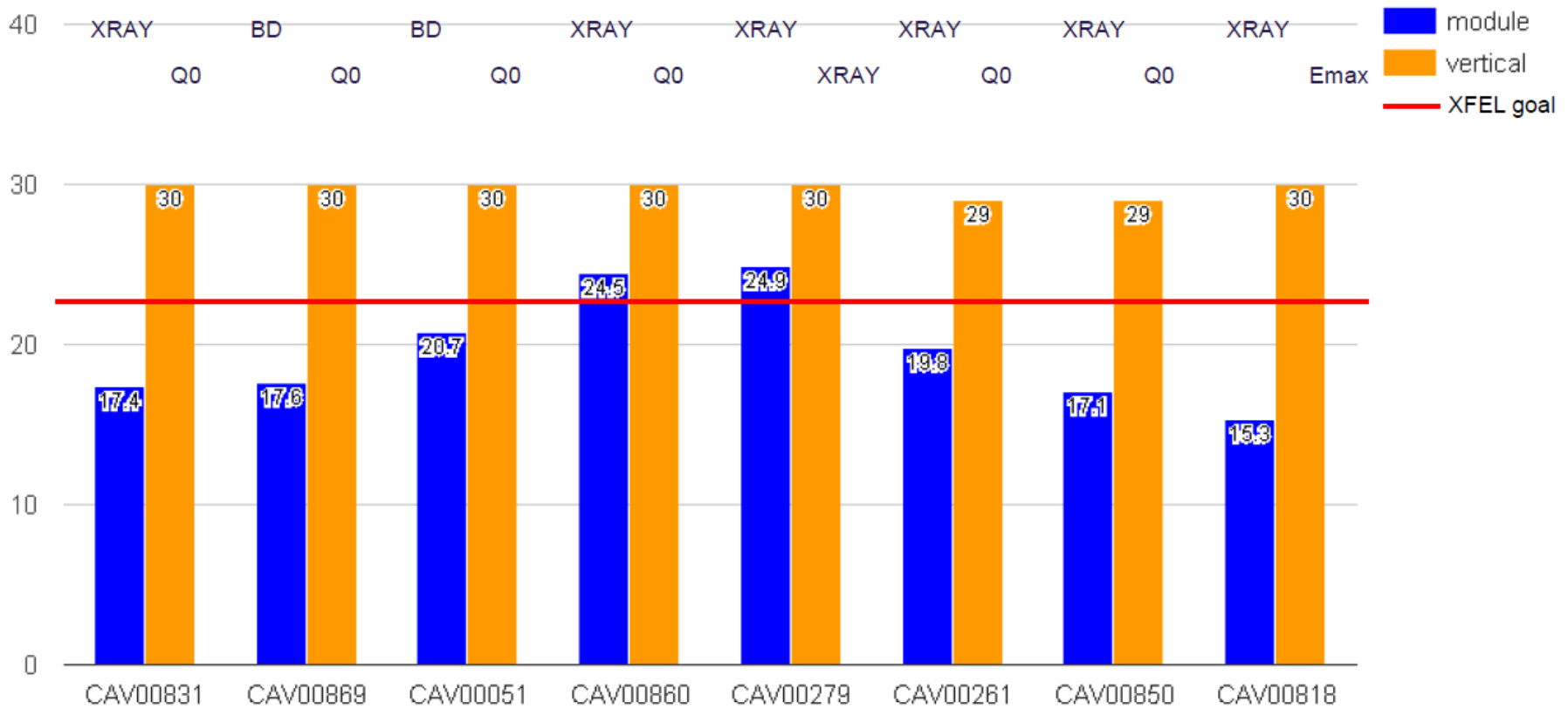

$\langle E_{acc} \rangle = 19,7 \text{ MV/m}$

XM46 string was **leaky in the clean room AND before shipment**. Both leaks have been repaired at Saclay but they generated 3 extra connections of the beam vacuum to pumping groups, and 2 additional venting-pumping

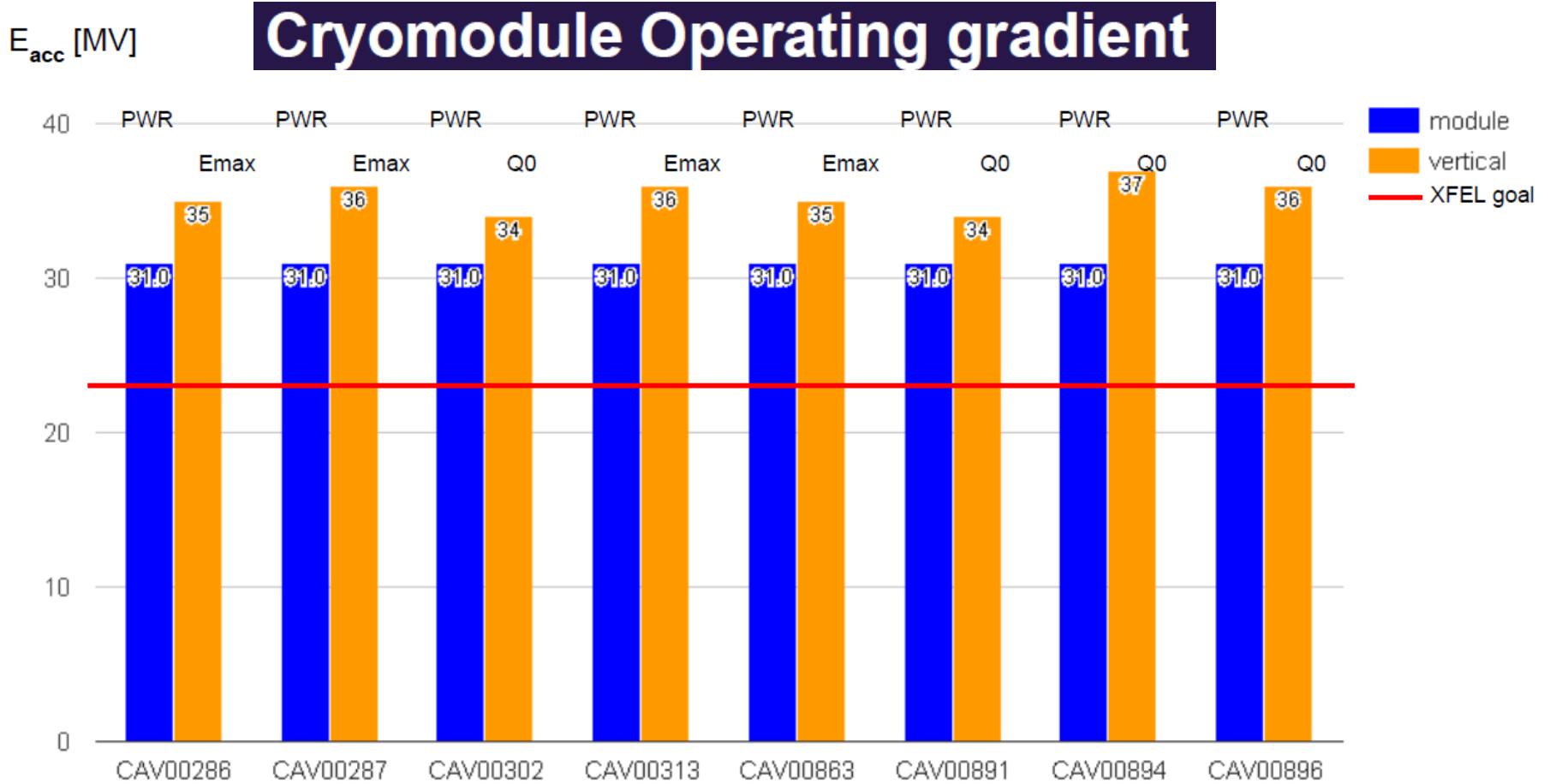

$$\langle E_{acc} \rangle = 31 \text{ MV/m}$$

**XM59 is an excellent module, assembled after the change of CR procedure.**



$E_{acc}$  [MV]

## Cryomodule Operating gradient

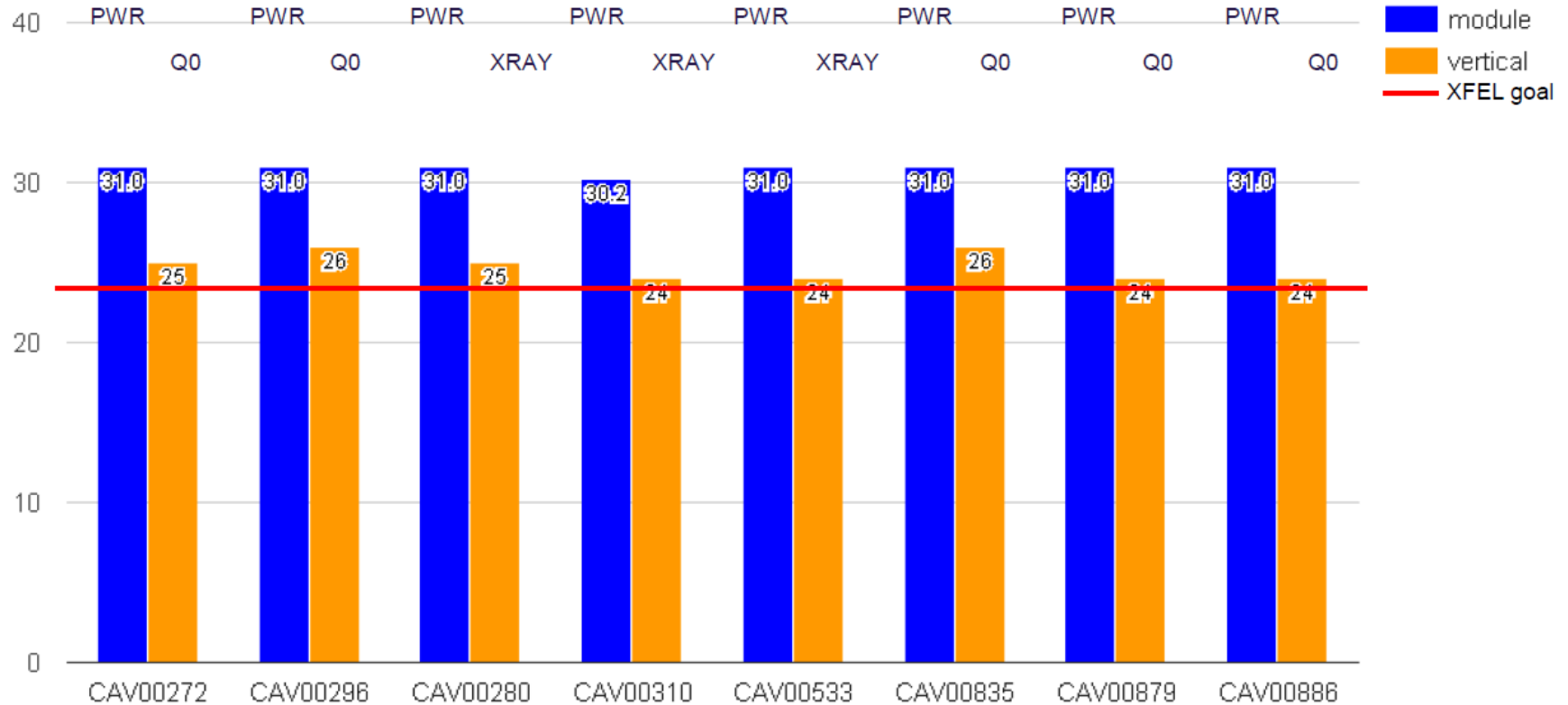

$$\langle E_{acc} \rangle = 31 \text{ MV/m}$$

XM62 is an excellent module:  
average gradient is +6 MV/m higher than in the Vertical Tests

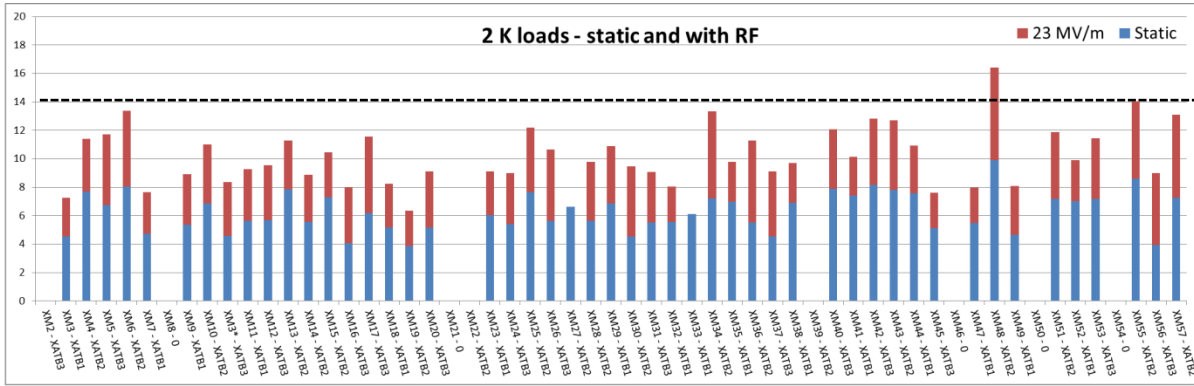

Specs for static + dynamic loads

14 W at 2K

Dynamic heat loads are measured at 23,6 MV/m

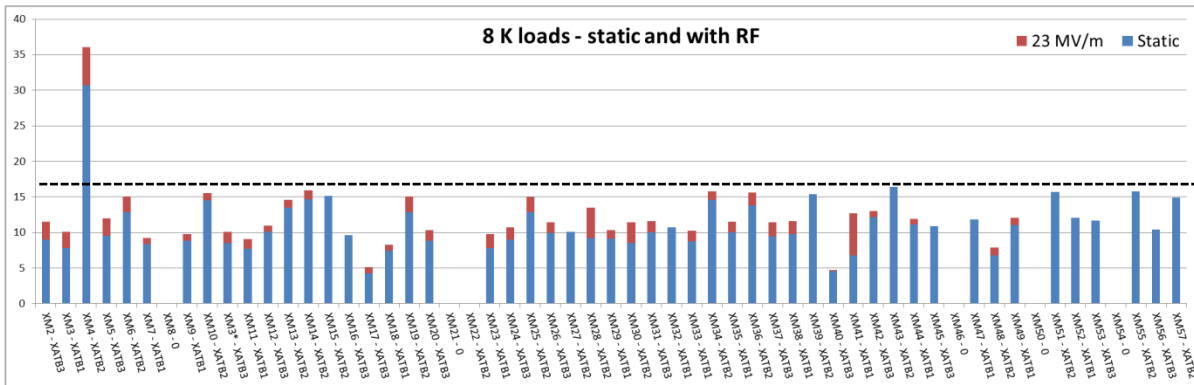

16 W at 5/8K

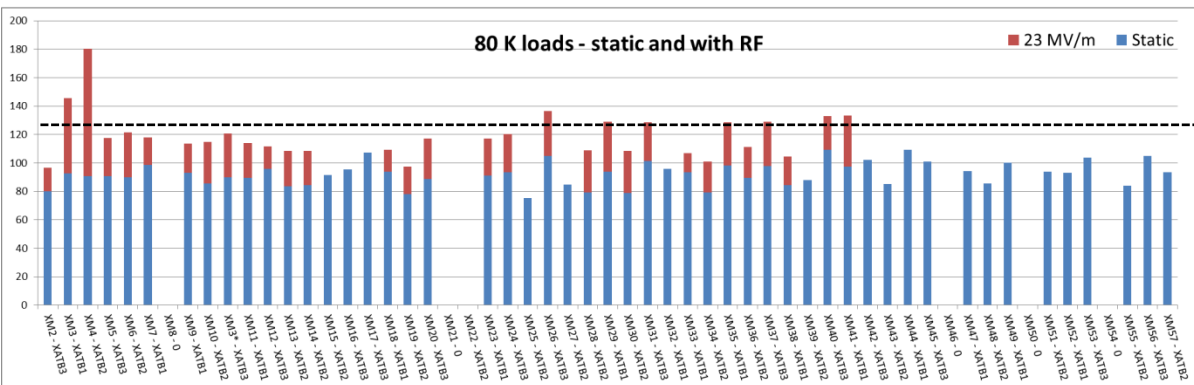

125 W at 40/80K

Courtesy S. Putselyk,  
S. Barbanotti



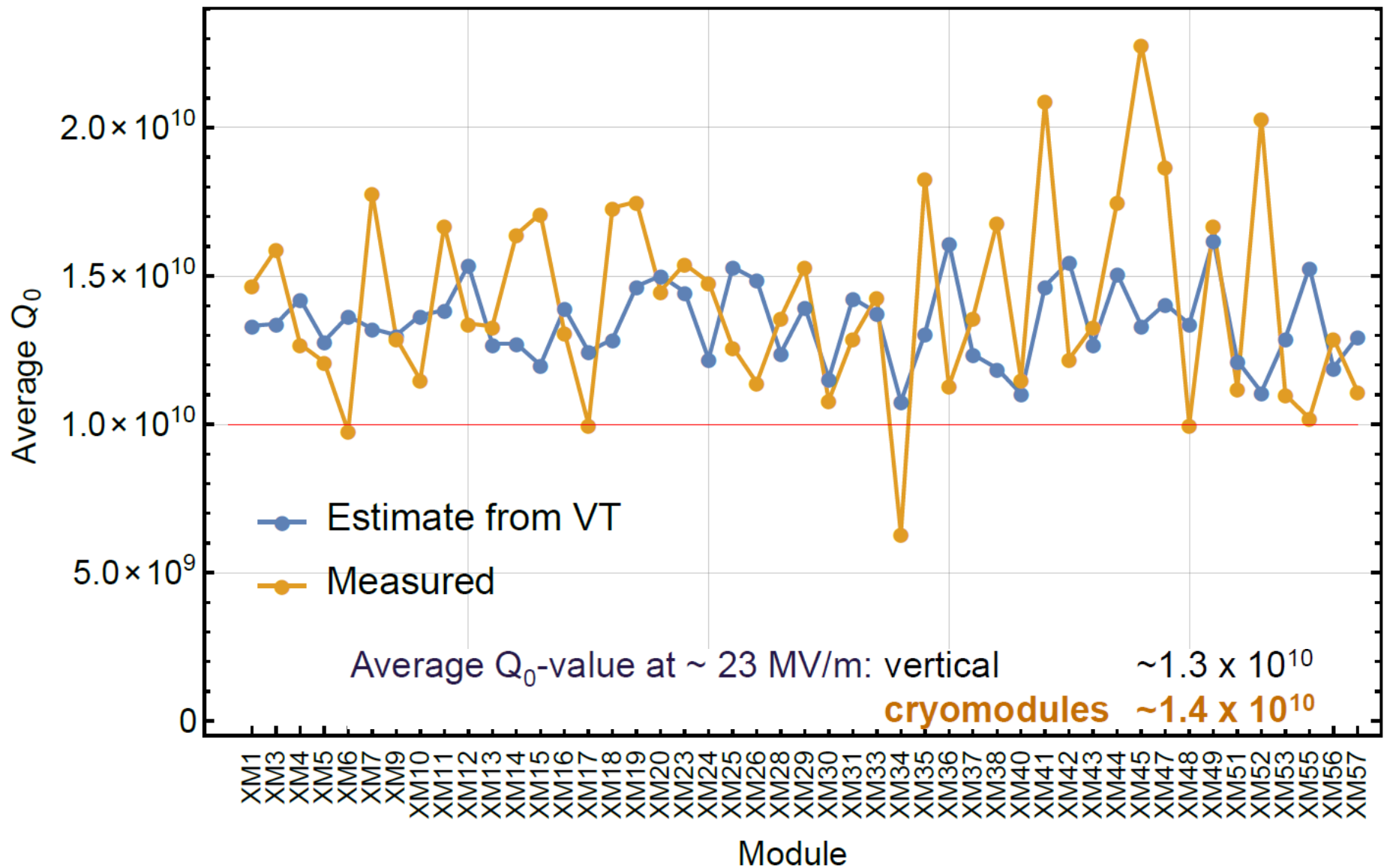



- Implementing and complying to the PED certification, in particular the RT norms 'NF EN ISO 17636-1 (2013) class B' for the execution and 'NF EN ISO 10675-1 (2013) level 1' for the interpretation, was a major effort over the year 2013, spanning XM-1 to XM11 modules.
- The porosity problem in the Titanium orbital welds was overcome by a combination of process cleanliness, US cleaning of Ti-bellows and welder 'humility'.

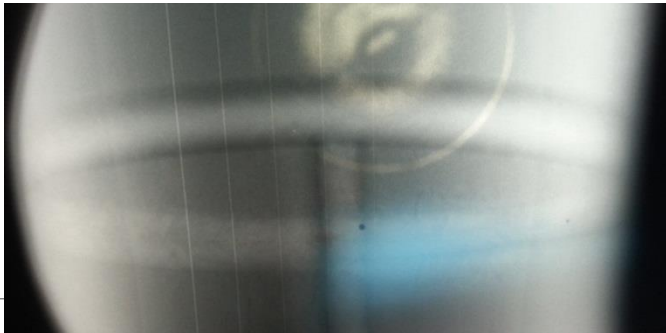

- Alsyom has now two good welders and one excellent welding coordinator within the 'EN ISO 3834-2' norm.

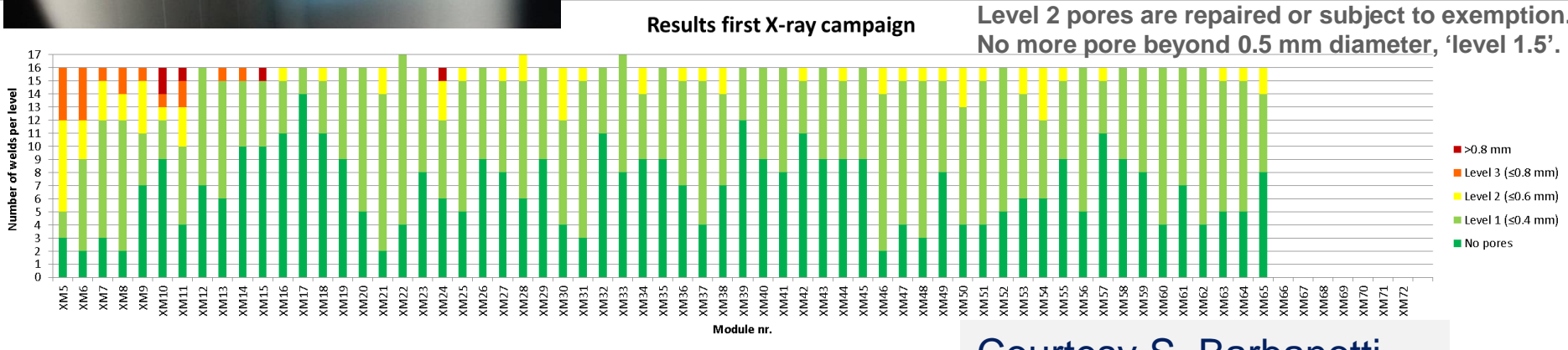

Courtesy S. Barbanotti



**European XFEL**

**Installation Progress XTL** Please use Hyperlink to view pictures

49 Modules installed  
2 Modules parked

1 RF-Station ready  
9 RF-Station in preparation

Status: 30.10.2015

**1**

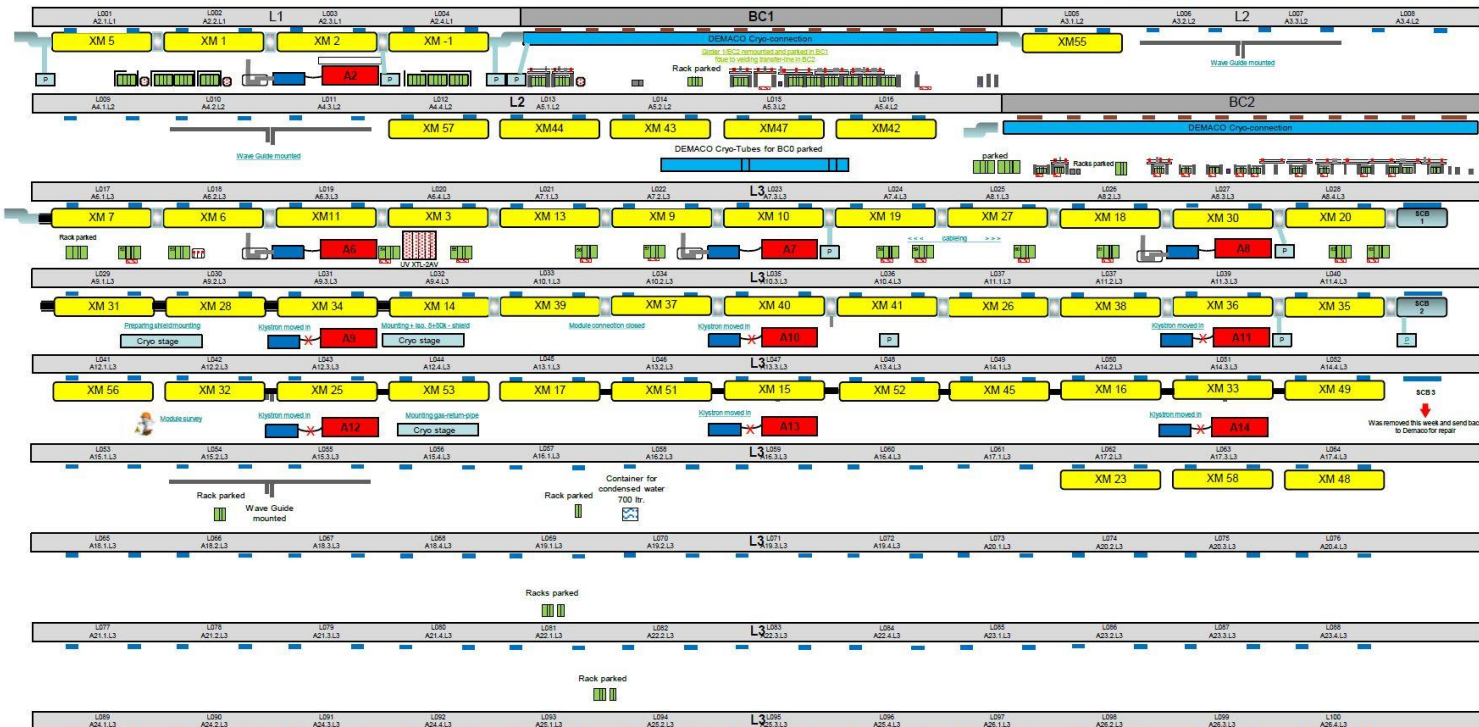

The energy reach of the 62 modules tested so far is 14.1 GeV (95% of VT average gradient)

Six modules under repair: XM-2, XM8, XM22, XM24, XM50, XM54

- E-XFEL Cryomodule Assembly at Saclay went through 4 main phases:
  1. Mastering the process [ T1/2008 – T1/2013 ]
  2. Mastering the infrastructure and tooling [ T3/2010 – T1/2013 ]
  3. Mastering the handling of non-conformities, both *imported*-PRODUCT and PROCESS-*generated* non-conformities [ T3/2012 – T3/2014 ]
  4. ‘Mastering’ the industrial operator
    - Productivity [ T1/2014 – T4/2014 ]
    - Quality Assurance [ T4/2014 – ongoing ]

This process depends inevitably on the early availability of the cryomodule components: *‘Practice makes perfect’*

- The difficulties of coupler assembly had been under-estimated by CEA
  1. e.g. cavity vs. coupler assembly includes 1 vs. 12 individual parts, ~139 vs. ~322 fastening hardware.
  2. about 8 couplers (both cold part and warm part) have been damaged due to bad manipulation and/or bad assembly.
- There are actual hints of better module RF performance correlated to Clean Room practice and procedures.

- E-XFEL Cryomodule Assembly at Saclay went through 4 main phases:
  1. Mastering the process [ T1/2008 – T1/2013 ]
  2. Mastering the infrastructure and tooling [ T3/2010 – T1/2013 ]
  3. Mastering the handling of non-conformities, both *imported* and *PROCESS-generated* non-conformities [ T3/2010 – T1/2013 ]
  4. ‘Mastering’ the industrial operator
    - Productivity [ T1/2014 – T1/2015 ]
    - Quality Assurance [ T1/2014 – T1/2015 ]

Like humans, XFEL Modules get better in their sixties !  
 Going to 100 ?

This process demonstrates the availability of the cryomodule assembly lines perfect

Assembly had been under-estimated by CEA

coupler assembly includes 1 vs. 12 individual parts, vs. ~1000 fastening hardware.

about 8 couplers (both cold part and warm part) have been destroyed due to bad manipulation and/or bad assembly.

- There are actual hints of better module RF performance correlated to Clean Room practice and procedures.

- E-XFEL Cavity production demonstrates the existence of EU vendors for cavities in the range 30 – 40 MV/m.
- E-XFEL AMTF demonstrates that RF testing is feasible) at a rate compatible with one ILC hub, even if 100% MT is the chosen option: 11-day cycle per module, with 3 MT bunkers in AMTF
- E-XFEL Cryomodule Assembly demonstrates that a 3-day throughput is feasible for ILC production, leading to about **120 modules per year** on one production site.
- When all assembly equipments are operating under nominal conditions, there are clear indications that RF performance of the cryomodules is impaired by:
  - The invasiveness of operators in the clean room
  - The invasiveness of vacuum operations on the beam vacuum. Both can be mitigated with good quality control and floor inspections
- Clean room assembly can be further improved, qualitatively and quantitatively, e.g. by unifying cold coupler and string assembly in a unique workstation (2 shifts required to achieve 3-day throughput).

- Thanks to my co-workpackage leaders:

WP03 K Jensch, WP09 S. Berry and A. Matheisen

- Thanks to the CEA team:

C. Cloué, C. Madec, S. Régnaud, C. Simon

C. Boulch, P. Charon, J-P. Charrier, M. Fontaine, Y. Gasser,

G. Monnereau, J-L. Perrin, T. Trublet, B. Visentin

- Thanks to ALSYOM

P. Pluvy, C. Abdi, F. Déau, F. Chatillon and their team

- Thanks to DESY and LAL colleagues

S. Barbanotti, H. Hintz, F. Hoffmann, W. Kaabi, D. Käfer, R. Klos, L. Lilje,

W. Maschmann, M. Schmöckel, H. Weise and many others

# Thank you for your attention

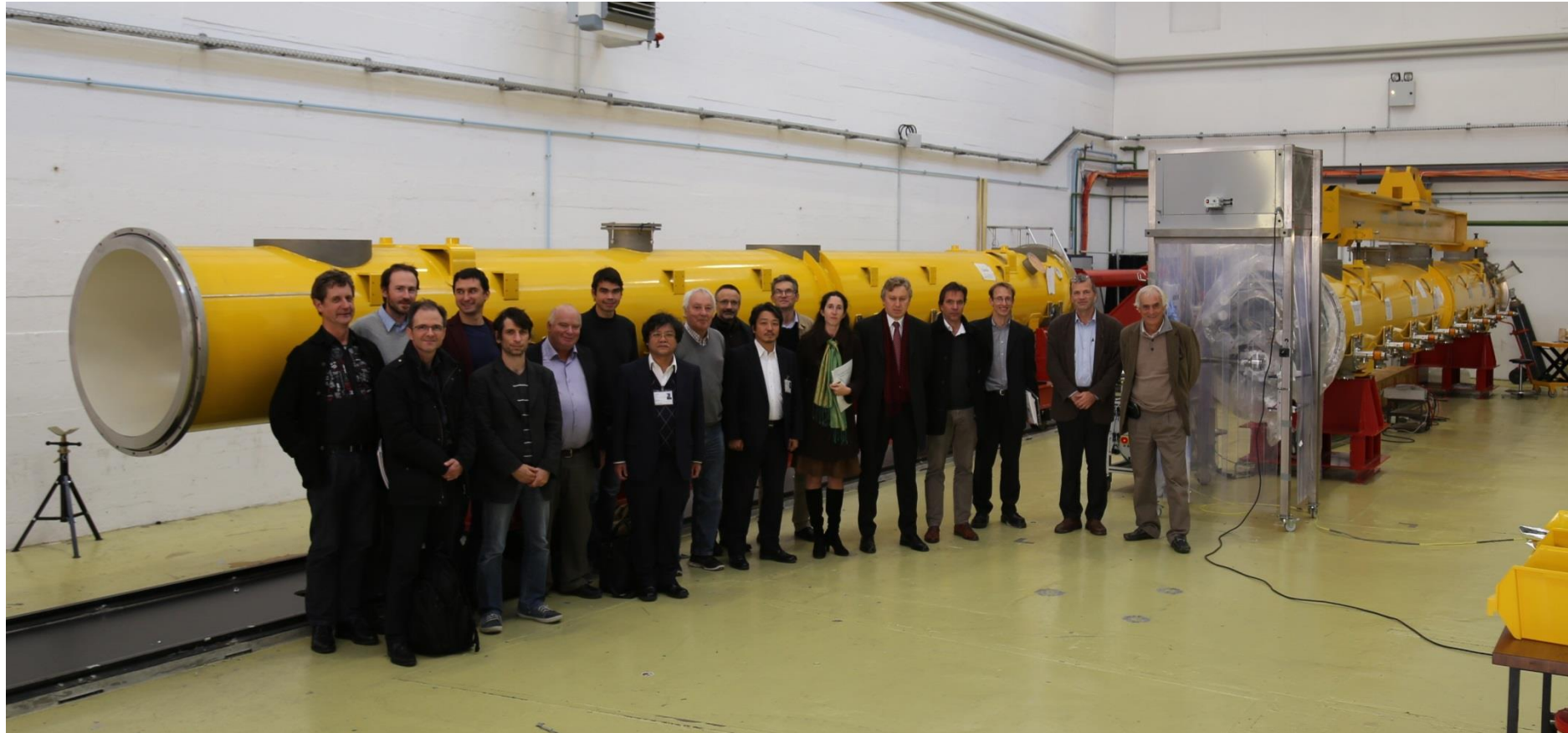



# Back-up slides

- The preparation, assembly and control work are described in **145 procedures**, 'Fiches d'Instruction', 'used' by the operators.
- The first set of draft procedures was written by CEA, during the Prototyping phase at DESY and Saclay, in English and appended to the Call for Tender Specifications for Industrial Operator selection
- Alsyom, the selected Industrial Operator, was in charge of updating these procedures during the Pre-Series phase (3 modules) and to translate them in French for their usage during the Series production phase.
- This process took much longer than expected.

Quality Control consists in:

1. Inspecting the incoming components
2. Controlling the assembly work in person on the workstations
3. Documenting the controls and non-conformities

Until end of 2014, the quality control group of Alsyom was too small (3 people) in such a way that Incoming Inspection and Documenting were performed in priority. CEA took the major part of the Assembly Work Controlling, essentially during pre-defined 'Hold Points' between WS.

The 'every day' or 'random' controls were too few and this led to many mal-fabrication, most of them recorded at DESY before or during cryomodule cold test !

In November 2014, the quality control group of Alsyom was increased to 5 people which, together with the better organisation, cover the need of QC.

CEA also took over the NCR editing on EDMS.

	FI_ASS_AH_149	V5	
	Montage de la boîte de transition pour les éléments d'origine THALES (THRI)		

	FI_ASS_AH_149	V5	
	Montage de la boîte de transition pour les éléments d'origine THALES (THRI)		

## MONTAGE DE LA BOITE DE TRANSITION POUR LES ELEMENTS D'ORIGINE THALES (THRI)



Cette Fiche d'Instructions (FI) définit les opérations de montage de la boîte de transition sur un Cryomodule XFEL et les moyens associés.

### FICHE D'INSTRUCTIONS OPERATIONNELLES

	ALSYOM			CEA	
	Rédigé par	Vérifié par	Autorisé par	Vérifié par	Approuvé par
Fonction	Rédacteur Technique	Chargé d'Affaire Projet XFEL	Responsable Qualité Projet XFEL	Responsable Technique	XFEL Fabrication Manager
Nom	A. CLIPPET	P. PLUVY	C. ABDI	S. BERRY	T. TRUBLET
Date					
Signature					

Ce document, établi par ALSYOM dans le cadre du Marché CEA n° 4000529715 du 28/07/2012, est la propriété du CEA.  
Aucune utilisation ou communication ne peut être faite sans l'autorisation écrite et préalable du CEA  
Page : 1 / 13  
Imprimé IM-SAQ 078 C

## 2. MOYENS

### 2.1. MATIÈRES CONSOMMABLES NÉCESSAIRES



Gant



Chiffon



Alcool isopropylique



Graisse mécanique Standard

### 2.2. MOYENS DE CONTROLE



Pied à coulisse



Niveau à bulle

### 2.3. OUTILLAGE STANDARD DE MONTAGE

Clés plates de 7-8-13-17	Embout BTR 2	Clé à cliquet	Clé BTR de 3
			Clé dynamométrique

Ce document, établi par ALSYOM dans le cadre du Marché CEA n° 4000529715 du 28/07/2012, est la propriété du CEA.  
Aucune utilisation ou communication ne peut être faite sans l'autorisation écrite et préalable du CEA  
Page : 5 / 13  
Imprimé IM-SAQ 078 C

	FI_ASS_AH_149	V5	
	Montage de la boîte de transition pour les éléments d'origine THALES (THRI)		

## 2.4. PIÈCES ET ÉLÉMENTS D'ASSEMBLAGE



Ce document, établi par ALSYOM dans le cadre du Marché CEA n° 4000520715 du 26/07/2012, est la propriété du CEA.  
Aucune utilisation ou communication ne peut être faite sans l'autorisation écrite et préalable du CEA

Page : 6 / 13

Imprimé IM-SAQ 078 C

	FI_ASS_AH_149	V5	
	Montage de la boîte de transition pour les éléments d'origine THALES (THRI)		

## 2.5. ÉQUIPEMENTS DE PROTECTION ET DE SÉCURITÉ



Chaussures de sécurité



Gants

## 2.6. INVENTAIRE DES PIÈCES À RETOURNER



Fourreau de protection couronne céramique

## 3. MONTAGE DE LA BOÎTE DE TRANSITION

### 3.1. PRÉPARATION DU POSTE ET DU MATÉRIEL



1. Préparer la F.I. référente au poste et la configuration du montage (Fig. 1)
2. S'assurer d'avoir au poste l'ensemble de l'outillage nécessaire au montage (Fig. 1)
3. Suivant le bordereau de configuration préparer les pièces d'assemblage (Fig. 1)

Ce document, établi par ALSYOM dans le cadre du Marché CEA n° 4000520715 du 26/07/2012, est la propriété du CEA.  
Aucune utilisation ou communication ne peut être faite sans l'autorisation écrite et préalable du CEA

Page : 7 / 13

Imprimé IM-SAQ 078 C

	FI_ASS_AH_149	V5	
	Montage de la boîte de transition pour les éléments d'origine THALES (THRI)		

## 3.2. MONTAGE DE LA BOÎTE DE TRANSITION

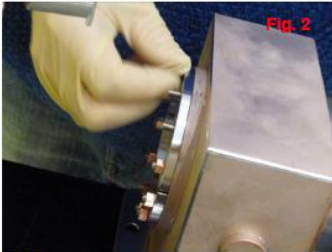

1. Démontez de la boîte de transition les demi-bridés de serrage montés sur sa bride arrière et vérifiez les goujons sont bien fixés sur la boîte de transition (Fig. 2)



2. A l'aide d'un chiffon propre imbibé d'alcool, nettoyez la boîte de transition en insistant plus particulièrement sur la portée de joint de la bride (Fig. 3)



3. A l'aide d'un chiffon propre imbibé d'alcool, nettoyez la portée de joint (bague épaulée) du coupleur chaud

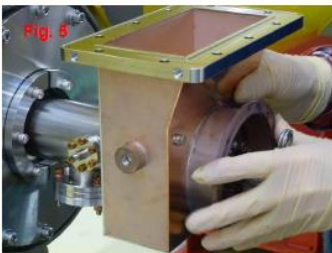

5. Monter délicatement la boîte de transition et la mettre en appui contre le joint RFC3 (Fig. 5)

	FI_ASS_AH_149	V5	
	Montage de la boîte de transition pour les éléments d'origine THALES (THRI)		



6. Monter à l'arrière de la boîte de transition, les deux demi-bridés initialement démontés et les maintenir à l'aide des écrous cuivre prévus à cet effet (le serrage doit être fait à la main sans outils) (Fig. 6)



7. A l'aide d'un niveau à bulle posé sur la boîte de transition, s'assurer de l'horizontalité de la boîte de transition, puis serrer à la main les écrous des demi-bridés de serrage de la boîte (Fig. 7)



8. Retirer délicatement le fourreau (film de protection de la bague céramique du coupleur) (Fig. 8)



9. A l'aide d'un chiffon imbibé d'alcool, nettoyez l'intérieur de la boîte de transition et précisément les portées de joint (Fig. 9)



10. Mettre délicatement en position sur la couronne intérieure de la boîte de transition le joint en cuivre

RFC1 (le plus grand des 3 joints à monter (dia ext 90.5 plan I72-CA-006))  
 RFC2 (le plus petit des 3 joints à monter (dia int 69.6 plan I72-CA-005)) préalablement nettoyés à l'aide d'un chiffon propre imbibé à l'alcool (Fig. 10)

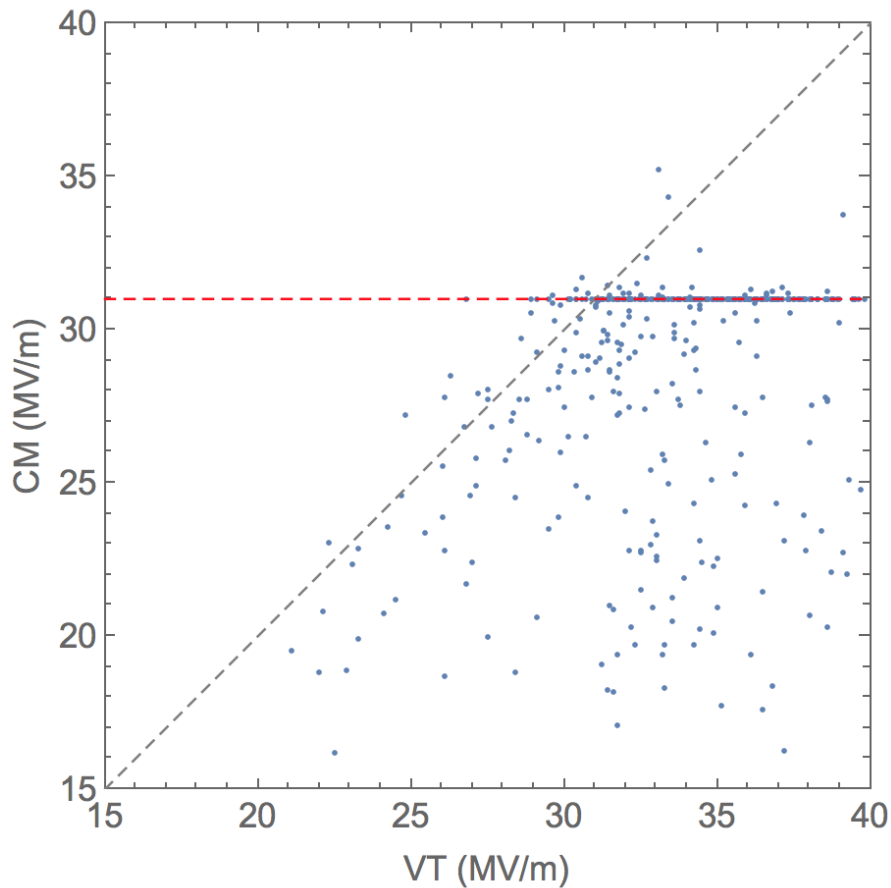

	$N_{\text{cavs}}$	Average	RMS	min	max
VT	455.	33.7	3.9	21.1	44.8
MT	455.	28.5	4.	13.7	35.2

Courtesy N. Walker