

Power Couplers Program

@

L.A.L.

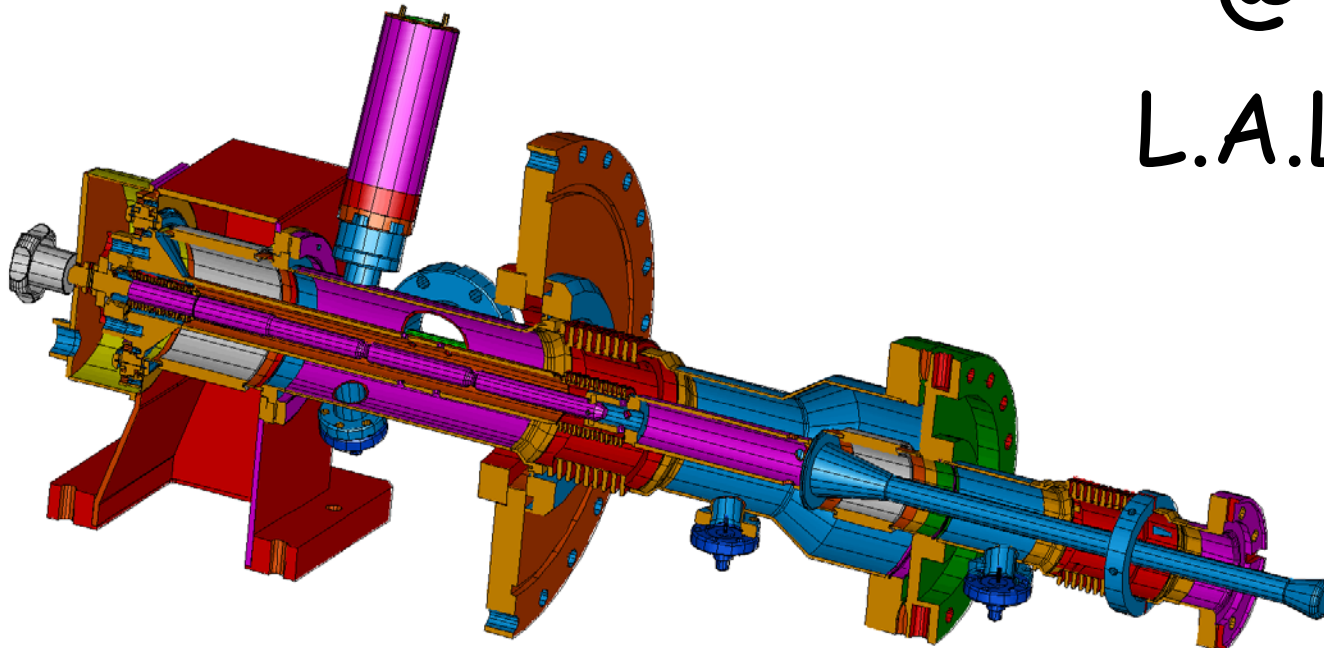

Different activities

- Manufacture & processing of 30 TTF-III Couplers in Industry for VUV-FEL
 - Design, construction and test of new proto-type power couplers: TTFV , TW60.
 - Industrialisation studies of the Coupler for the European X-Ray Free Electron Laser (~1000 couplers).
-
- Design and construction of TiN coating bench.
 - Conditioning studies ~ 10 couplers
 - Associated studies (surface, vacuum etc)

Design, construction and test of new proto-type power couplers (TTFV , TW60).

Study, simulations & design (P.Lepercq,S.Cavalier). Setting up the call for tenders and evaluation of offers.

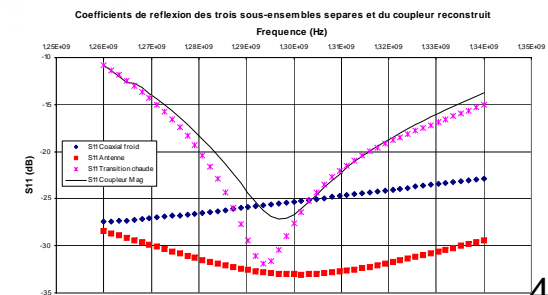
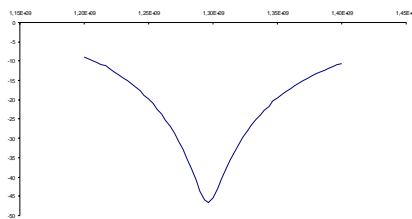
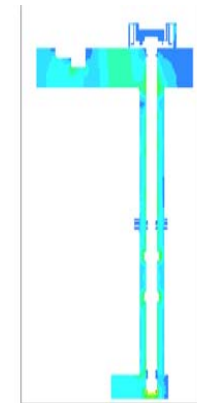
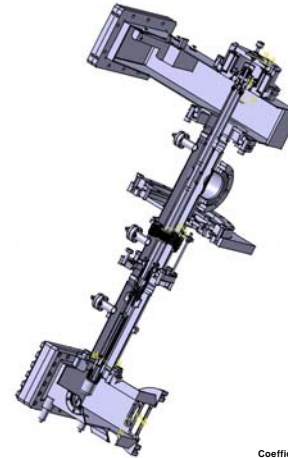
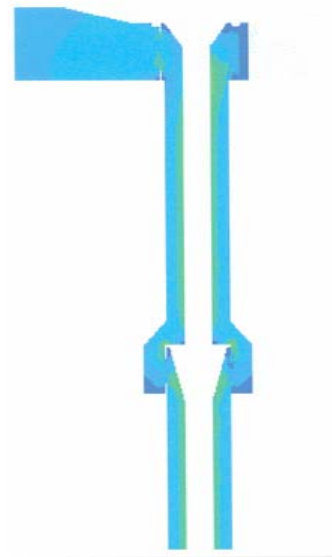
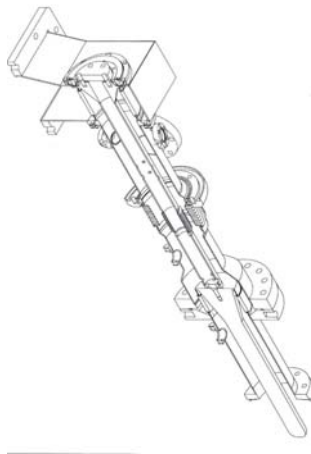

Alessandro Variola

Industrialisation studies of the Coupler for the European X-Ray Free Electron Laser

- Thermal studies, tolerances, simulations.
- Setting up the call for tenders and evaluation of offers.
- Define the procedure for quality control and final decision

Principle of "Definition contract for industrialisation studies"

- Essentially intellectual work:
 - Define all manufacturing processes
 - Risk analysis (process, logistics)
 - Determine cost in series and justify
- Produce validation models and 2 prototypes

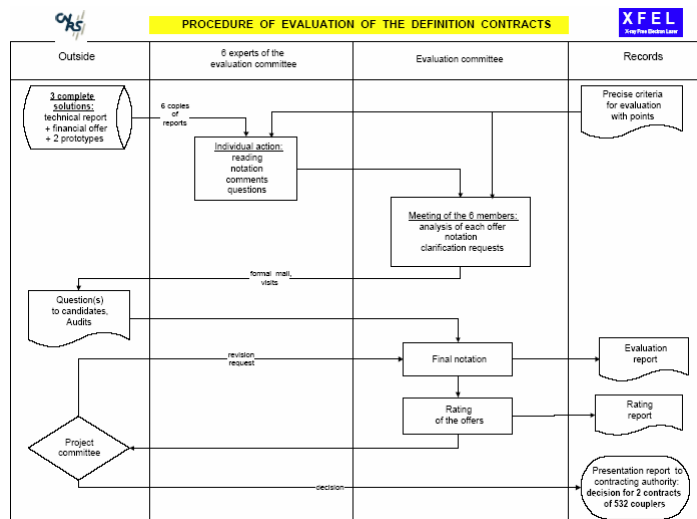

Particularities

- several contracts will be awarded on the same subject: **3 contracts are financed**
- 2 teams will be selected after final evaluation
- contracts for manufacturing 2 series of 532 XFEL couplers will be awarded without new call for tenders
- the 2 contracts may be awarded to a single company

Advancement

- **Conditioning:**
 - Agreement with DESY for the quality procedure (very extensive documentation by L.Grandsire)
 - Communication : Web site => reports, conditioning advancement, internal notes, measurements, minutes (B.Mouton)
 - Improvement of the technical equipment and of quality assurance for the assembly procedure: 1) Water resistivity measurement on the outgoing flux 2) Increased ultra pure water reservoir 3) Continuous RGA spectrum acquisition 4) Modified vacuum system to assure a delivery of the cold part under sealed vacuum 5) Box and supports for delivery (L.Grandsire, C.Prevost & B.Mercier)
 - Start of the conditioning of the VUV-FEL couplers in "continuous mode" testing both with and without "in situ baking".
 - First results produced and ongoing data analysis (H.Jenhani, see next page...)

First results

- 3 pairs already conditioned (1 pair/~ 3 weeks)

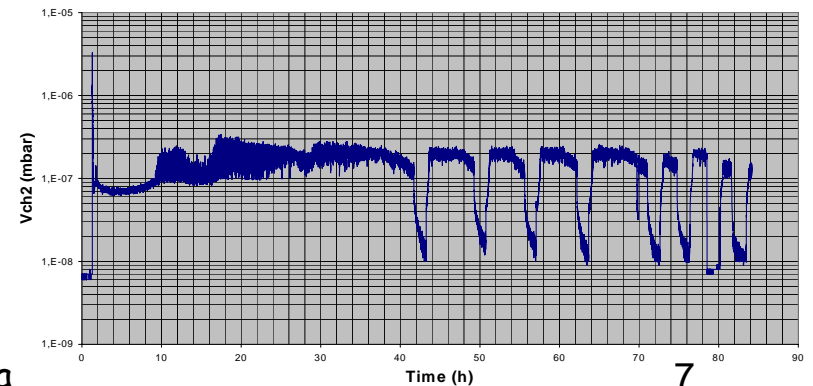
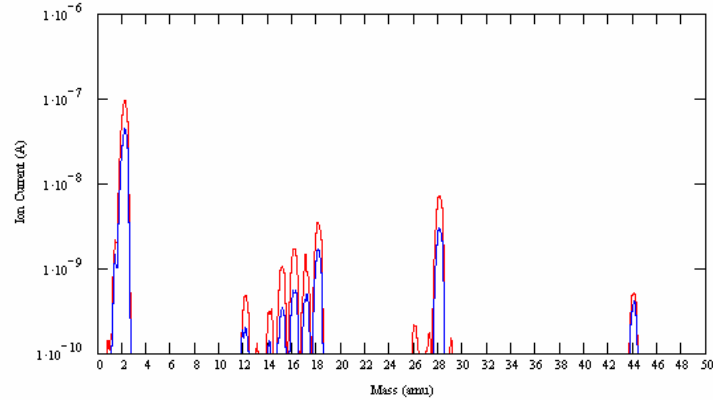
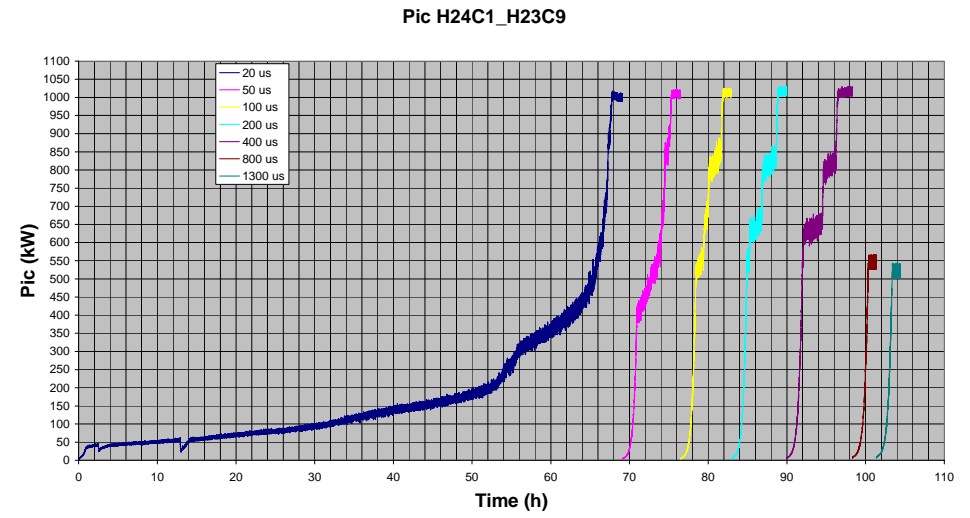
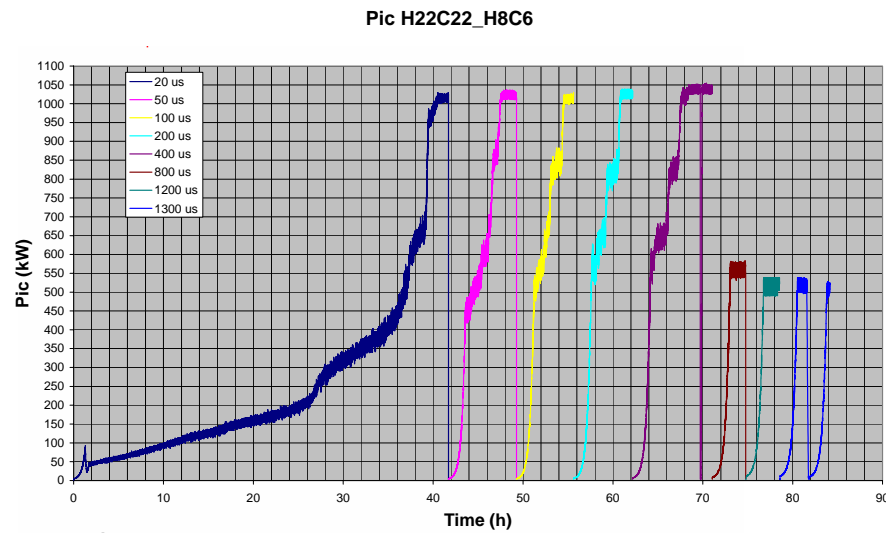

Alessandro Variola

Processing time

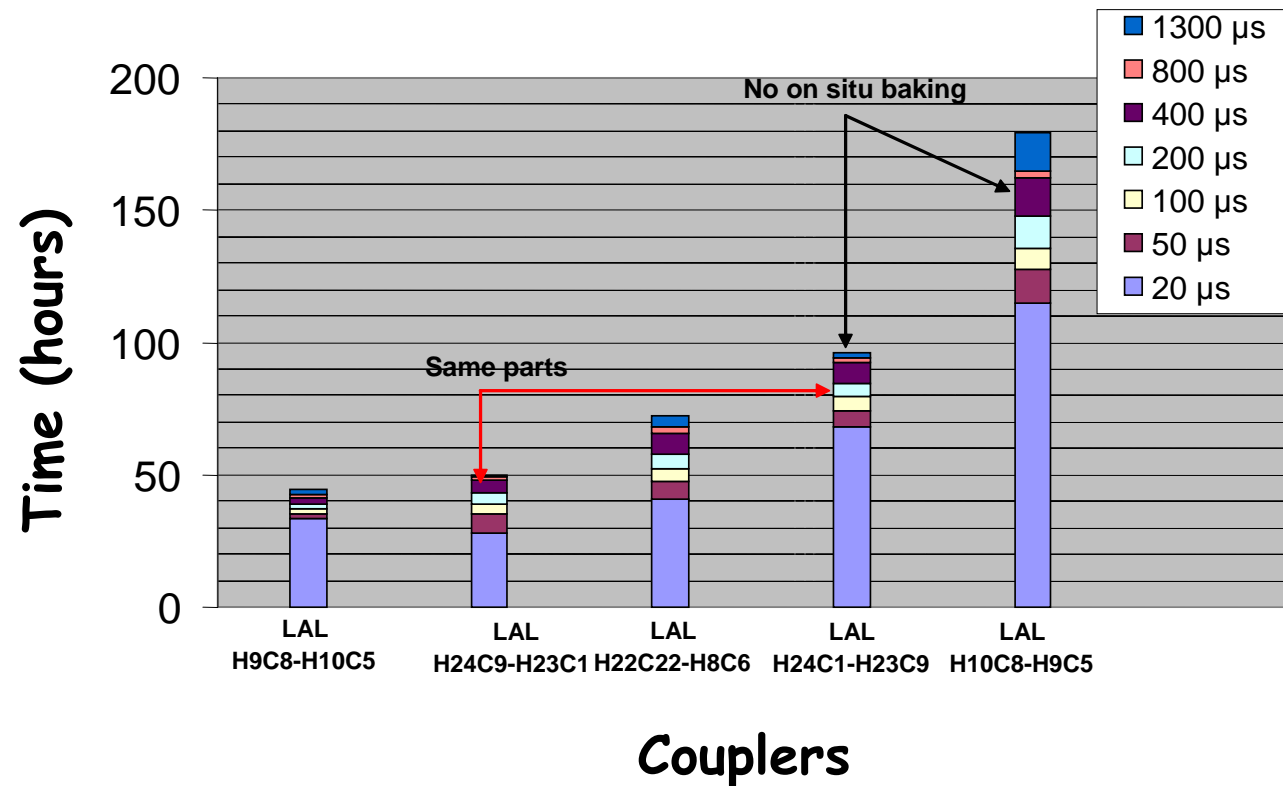

10 "spare" couplers for different measurements

- **Some ideas for Conditioning Studies :**
 - DC bias sweep to provoke multipactor
 - Argon discharge cleaning
 - Ceramics coated with Zr-Va-Ti
 - Fully TiN coated coupler
 - Effect of different environments on re-conditioning times (vacuum, N₂,....)
 - Establish maximum limits for interlock thresholds
 - Effect of assembly of warm part in class 10 clean room
 - Central antenna as an e⁻ pick-up
 - And other ideas are discussed.....

- New Prototypes

TTF V call for tender published
Industries proposal analyzed
Assignment of the contract to ACCEL

TW60 Documentation delivered to the in2p3 administration.
Call for tender to be published very soon.

One year for delivery....we hope to receive, test and validate the models before summer 2006. In the meanwhile thermal & multipacting studies and simulations will be carried out

XFEL industrialisation

(talk from S.Prat)

- We obtain a third contract
- The call for tender has been published
- A procedure for the contract following has been established
- A final decision for the composition of the committee that will evaluate the contractors is foreseen soon.

Others....

- TiN team decided.
- Ideas for conditioning measurements evaluated
- Data Analysis
- Surface activity proposed (with also external collaborations)
- NEG?

Conclusions & Outlook

- The power coupler activity is a priority in the accelerator activity of LAL.
- We have progressed in the definitions of the quality procedures and started the conditioning of the VUV FEL couplers. We have improved some technical aspects to increase the quality assurance. First results are being analyzed.
- A communication bridge between LAL and DESY has been established. Full documentation is on the WEB.
- TTF V => Assigned, TW60 => Soon call for tender published.
- TTF III - XFEL industrialization : 3 contracts, call for tender already published.
- New activities are foreseen in the next two years (TiN Bench, Surface analysis, Tests on spare couplers.....)