

ILC/ATF-2 Laser System

Sudhir Dixit (JAI, Oxford)

Aim

1. To develop a laser system for intra-train diagnostics of ILC particle beams

Electron/positron beam profiles/sizes – Estimation of Emittance/Luminosity
All along accelerator complex - Linac, BDS and possibly at IP?
Comparison of train to train characteristics

2. To test the proof of principle at ATF-2 in ILC like beams

The laser system will function as a Laser-wire used in both the modes

Directly focussed laser beams or Laser based interference fringes

Laser beams compatible with ILC beams needed

Time domain

ILC particle beams

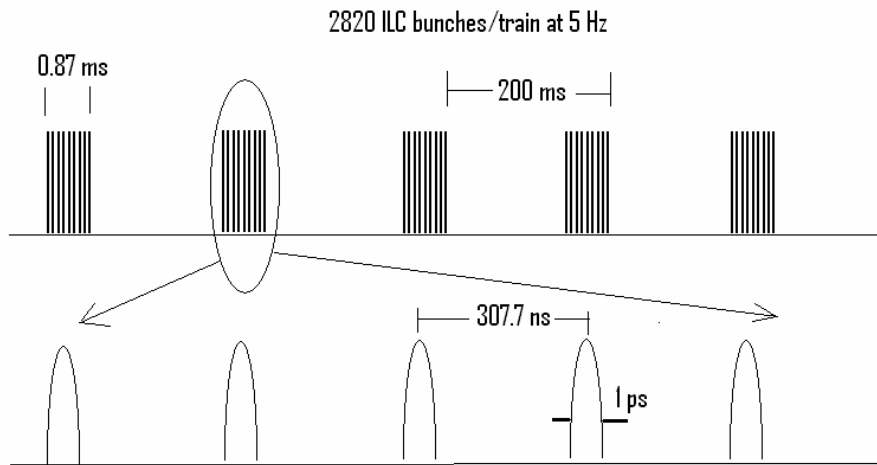

Space domain

ILC particle beam sizes

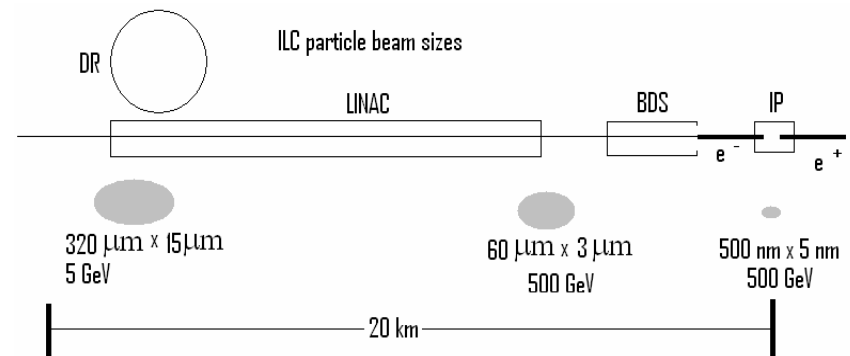

Mode locked laser beams

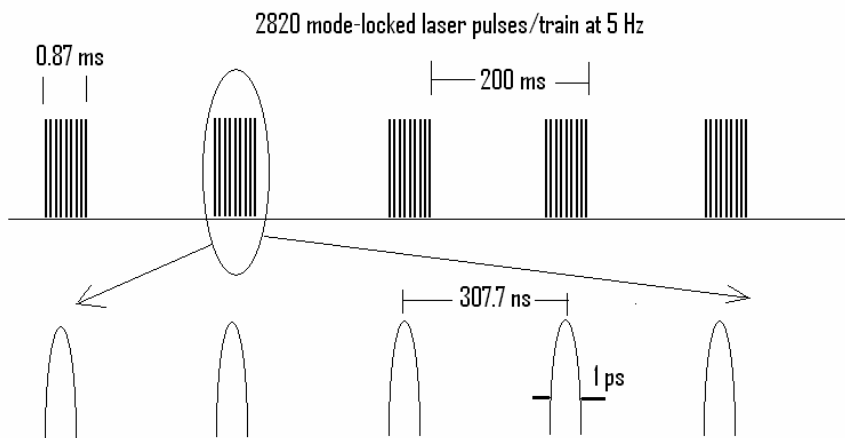

Laser scanning of particle beams

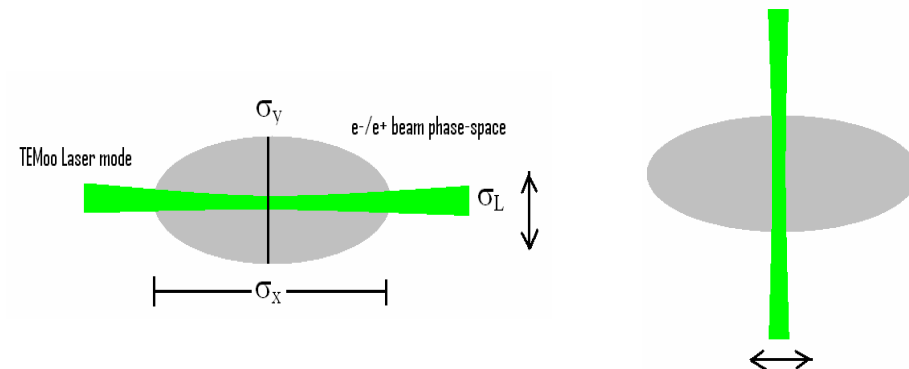

ILC diagnostics laser system parameters

Laser parameters	<u>Guidelines/Values</u>
1. Repetition rate	<u>ILC repetition rates</u> 3.25 MHz or 6.5 MHz \pm 25 kHz Sync. to reference RF < 1ps rms
2. Pulse duration	<u>ILC bunch length</u> , 1 ps
3. Overall temporal structure	<u>ILC time structure</u> , 870 μ s@ 5Hz
4. Beam quality	TEM ₀₀ mode, $M^2 \cong 1$, Gaussian beams, High pointing stability
5. Wavelength	<u>Focus laser beam size and Compton X-section</u> , 250-500nm
6. Peak power	<u>No. of Comptons</u> , 10MW/250nm for 250 – 500 GeV ILC beams

ATF-2 vis-à-vis ILC for laser based diagnostics

Parameters	ATF-2	ILC	Comments
Energy	1.3 GeV	250 GeV	Larger Compton X-section for ATF-2
Bunch repetition rate	6.49 MHz	6.5 MHz	6.49 MHz \pm 25 KHz covers both ILC & ATF-2
Bunches per train	3 to 20	2820	-
Bunch length	20-30 ps	1 ps	Variable laser pulse length system, 1ps -20 ps, works for both ILC & ATF-2
IP beam sizes	3000 nm x 37 nm	500 nm x 5 nm	IP measurement relatively easier for ATF-2

1 ps pulse width ILC laser beams can measure single bunch temporal profile and bunch length of ATF-2 particle beams

Laser design ($\lambda \cong 1 \mu\text{m}$) for $P = 50 \text{ MW}@ f \cong 6\text{MHz}$

Option 1: 500 $\mu\text{J}@10 \text{ ps}@6 \text{ MHz}$; Pulse train power = 3 kW

Option 2: 50 $\mu\text{J}@1 \text{ ps}@6 \text{ MHz}$; Pulse train power = 300 W

A laser master oscillator - power amplifier/s (MOPA) system is needed

An attractive futuristic choice (option 2)



A mode-locked fiber laser oscillator- preamplifier (1047/1053/1064 nm) system followed by high power DPSSL, Nd: YAG or Nd:YLF amplifier/s

An alternative choice, already employed over the years (option 1)



A diode/flashlamp pumped mode-locked Nd:YLF/Nd:YAG MOPA

Choice on 2nd/4th harmonic crystal : LBO/BBO (250 nm – 500 nm)

Fiber lasers for Accelerator R & D

High quality beams: Diffraction limited divergence, excellent beam profiles, very low pointing jitter

Wide range of pulse- widths: 100 fs to 10 ps

Ultra-low noise jitter: 10s of fs

Rep. rate: kHz to 10s of MHz

Pulse energies: 1 micro-joules (6 MHz, 1 ps pulses) to
1000 micro-joules (50 kHz, 200 fs pulses)

Long diode life: 10 years

Issues to be worked on more seriously:

Exact rep. rate control and synchronization to external RF signal by fiber length tuning,

- By temperature variation - Slow process
- By a PZT drum - Fast process

Choice on Lasing materials

Laser medium	λ (nm)	Stimulated emission x-section (10^{-19} cm^2)	Upper laser life time (μs)	Gain Bandwidth (nm)	dn/dt $10^{-6}/^\circ\text{C}$	Thermal conductivity W/mK	Pump λ (nm)
Nd:YAG	1064	2.8	230	0.45	7.3	13	808/LD
Nd:YLF	1047 1053	1.8 1.2	490 540	1.4	-4.3 -2.0	7	800/LD
Nd:VAN	1064	20	90	0.8	4.7	5.1	808/LD
Nd:Glass	1053	0.42	330	20	8.6	1.2	808/LD
Yb:YAG	1030	1.0	1000	5	9	14	940/LD
Yb:S-FAP	1047	0.8	1300	4.7	-9	5	900/LD
Yb: Glass Fiber laser	980 - 1070	0.5	2000	90	-0.2		975/LD
Ti:Sapphire	700 - 1100	4.0	3.2	230	73	26	500/Laser

Stimulated emission x-section \rightarrow Laser Gain

Upper laser life time \rightarrow Amplifier energy storage

Gain bandwidth \rightarrow Laser pulse duration

dn/dt \rightarrow Wave-front distortion, Laser beam quality

Laser crystal technology \rightarrow Damage threshold, Size, Uniformity, etc

Laser amplifier design

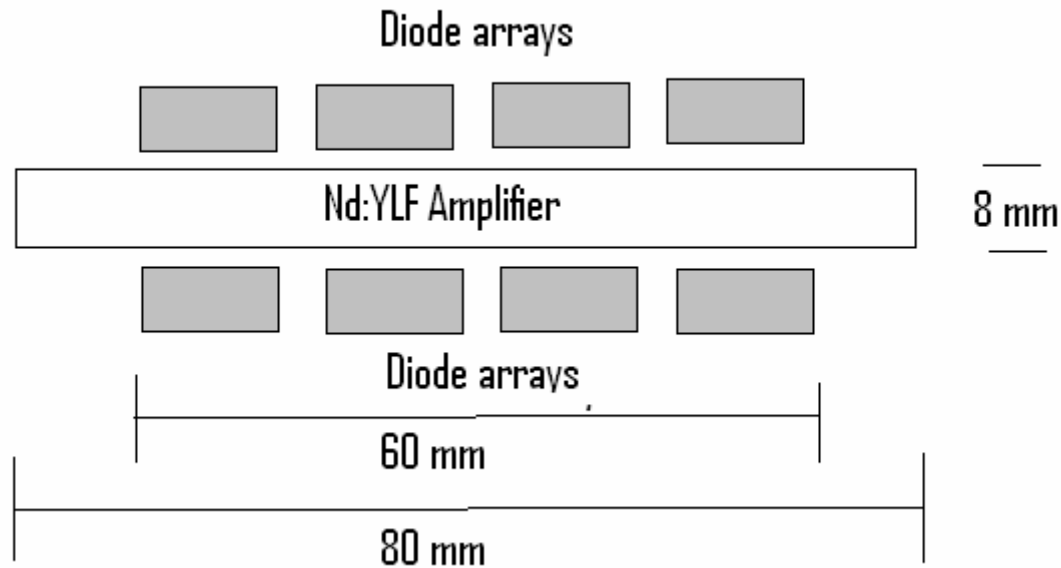

Thermal fracture data

For pulse train power
= 3 kW

And diode duty cycle
= 1 %

Average laser power
= 30 W, i.e.

5 W/cm \ll Frac. limit

- The amplifier is pumped by 16/20 diode arrays distributed in 4/5 rings.
- Each ring contains symmetrically located 4 diode arrays.
- These 4/5 rings are rotated w. r. t each adjacent one suitably to maintain excellent uniformity of pumping

On pump laser diodes for ILC LW power amplifier/s

Pump diodes specifications: Modular design with relatively lower cost

- Each diode module --- Standard 1 cm linear bar/array
- Peak power of each bar --- 500 W at 5 Hz, at 800 nm
- Total input power to amplifier --- 10 kW
- Diode pulse duration --- 2 m-sec
- Duty cycle --- 1 %

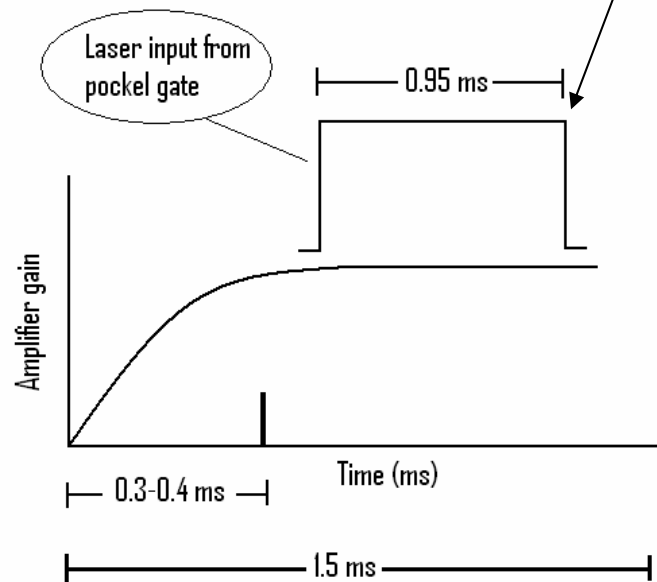

On non-linear optical frequency conversion: Generating harmonics

For ☹️ 1000 nm to ☹️ 500 nm: The best choice is Type I non-critically temperature phase matched LBO crystal

- No walk-off - Long interaction lengths, Excellent circular beam
Gaussian profile with good coherence,
High Conversion efficiency > 70%
- Large acceptance angle – 100 mrad
- Large temperature bandwidth – 4° c at 150° c
- Damage threshold– 20 GW/cm² at 1053 nm, a factor of 2 to 4
larger than all other crystals e.g. KDP, KTP, BBO

For ☹️ 500 nm to ☹️ 250 nm: The choice is limited to Type I critically phase matched BBO crystal

Large walk-off, Elliptical output beam (needs correction)
Conversion efficiency - 20 to 30%

Tentative ILC/ATF-2 Laser system

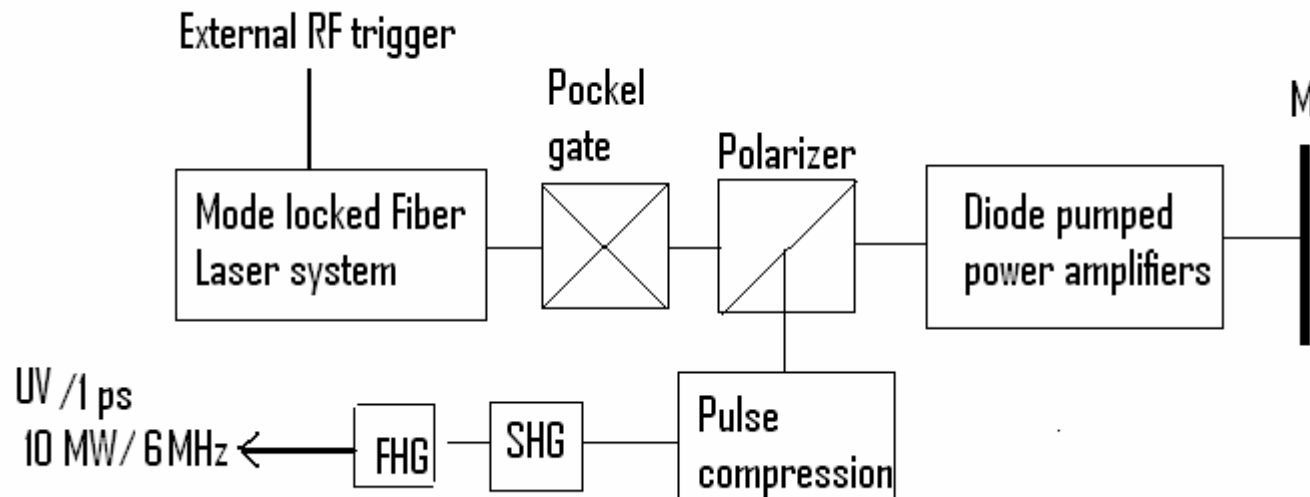

Plan of work

Phase 1: Purchase an oscillator + pre-amplifier laser system working at around 1 μm wavelength, 1 μJ pulse energy at 6 MHz, 1-10 ps pulse width

Status: Tender for mode locked laser system raised on 18th May, 2006

Tender opens today, 3rd July @ 12:15 hours

We expect the laser system delivery by the end of this year, 2006

The Laser tender

The University of Oxford require a CW Mega-Hertz repetition rate, high power mode locked laser for Laser wire project. The main features are pico-second duration pulses, good pointing stability, low jitter, repetition rate tune-ability, high beam quality, good energy stability. The laser would be diode pumped operating at around one micron wavelength. This laser system is going to be oscillator/preamplifier input to a much higher power (50 MW) laser amplifier system.

Wavelength of operation within band 1020 nm -1070 nm:

Preferred value: 1047 nm

Wavelength outside this range could be considered if condition 16.2 is satisfied.

Set repetition rate: 6.490 MHz

Repetition rate tuning range: ± 25 kHz

Tuning resolution: < 1 kHz

Pulse timing jitter: < 0.5 ps at a fixed repetition rate

Mode locked pulse duration: < 10 ps

Preferred value: 1-2 ps

Clean pulses without side-bands

Output bandwidth: < 2 nm

Laser pulse energy: Quote for all the systems with energy from 50 nJ to 1 μ J

Laser beam M^2 : < 1.2 , as close as possible to ideal value of 1.0
TEM₀₀ mode, very smooth near and far-field beam profiles

Laser pointing: < 0.1 x Diffraction limit

Pulse energy stability: $< 2\%$ rms

Long term stability: $< 5\%$ over a period of 8 hours

Laser polarization: Linear, Polarised output 100:1 or better.

Trigger: Synchronized to external RF clock

Laser pump source: Diodes

The laser system must be capable of being upgraded by addition of extra amplifier stages to about 50 MW peak power in future. Suppliers may suggest the schemes.

Future plans

- To boost the laser pulse energy from 1 μJ to 500 μJ by power amplifiers
- To study non-linear frequency conversion to UV
- To completely characterize the optical beams at every stage
- To develop optical beam delivery systems

All the in house R&D required to achieve such a big task, is being planned.

The Laser Lab

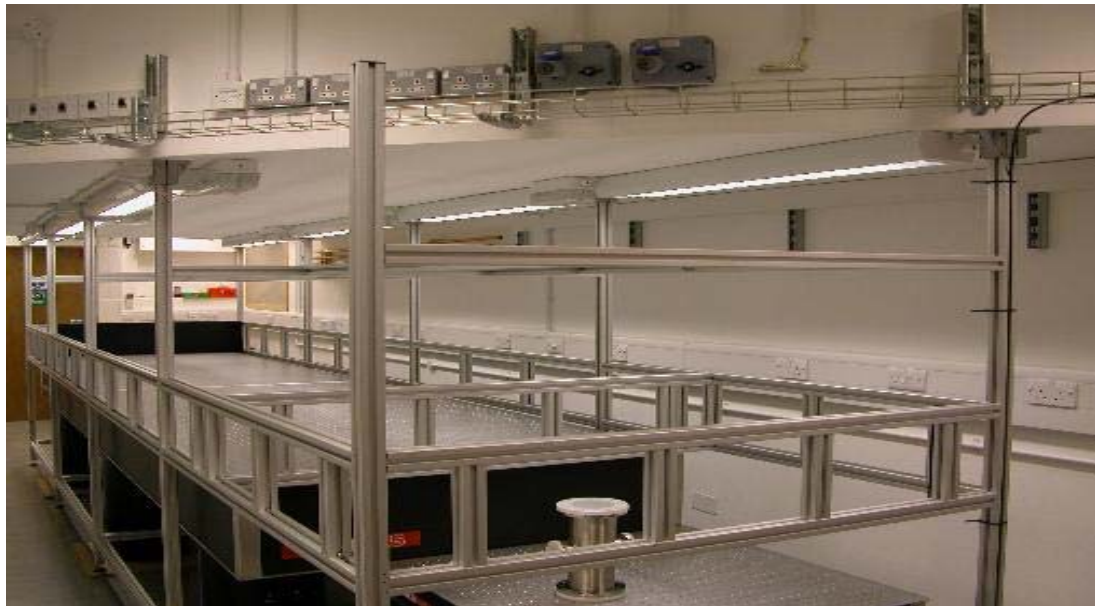

Cost estimates

1 μ J pulse energy mode –locked laser master oscillator + pre-amplifier system + closed loop repetition rate control at 6 MHz	£ 150- 160 k
10 kW peak power diode pumped laser amplifier (2 Nos.)	£ 150 – 180 k
Frequency conversion	£ 15-20 k
Optical beam delivery system	£ 20-25 k
Lab. Instruments	£ 60 – 70 k

Thank You