

Profile Monitor Based on Interferometry

*J.Urakawa, Laser Wire Mini-Workshop in Oxford
2006. 7. 2*

- 1. Pulsed laser wire development,*
- 2. Principle of Laser Interferometer with an optical cavity,*
- 3. Plan of Test Experiment,*
- 4. Future plan.*

1. Pulsed laser wire development

● Experimental results (Pulse Laser Storage)

Laser:

Mode Lock: **Passive
SESAM**

Frequency:
357MHz

Cavity length: **0.42 m**

Pulse width: **7.3 p sec
(FWHM)**

Wave Length: **1064 nm**

Power: **10W**

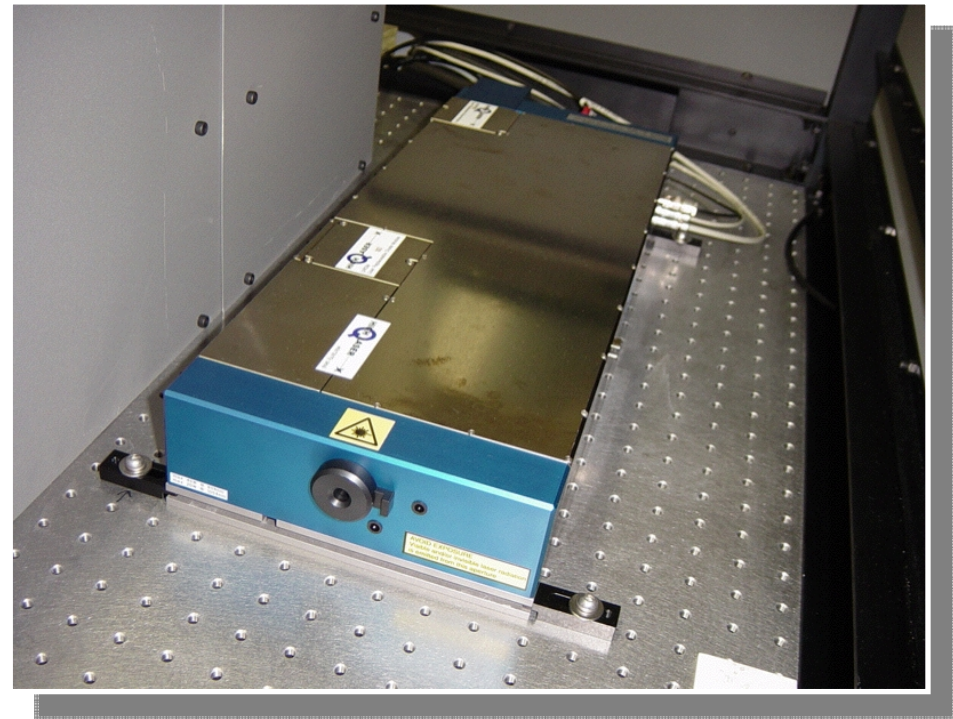

SESAM: SE*mi*-Saturable Absorber Mirrors

Ext. Cavity:

Cavity:

Super Invar

Cavity length:

0.42 m

Mirrors:

Reflectivity:

more than 99.9%

Curvature:

210 mm ($\omega_0 = 40 \mu\text{m}$)

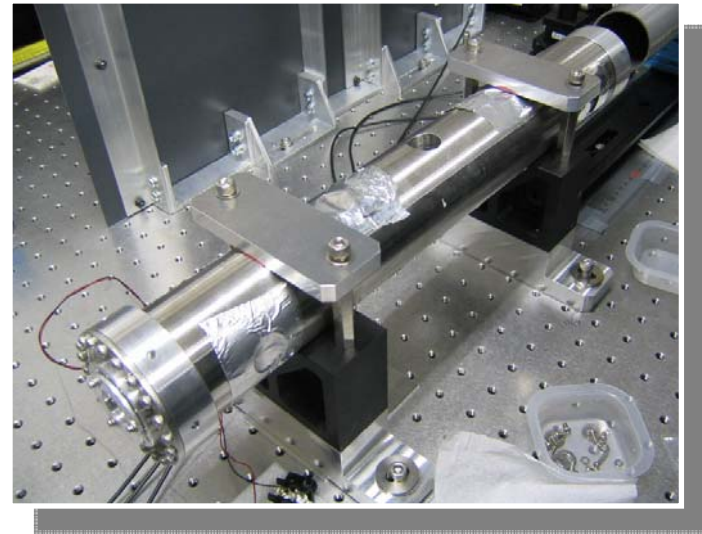

2. Principle of Laser Interferometer in an Optical Cavity

$$FSR: \Delta \nu = \frac{c}{2L}$$

$$T = \frac{1}{\Delta \nu} = \frac{2L}{c}$$

$$\nu_0 = N \times \frac{c}{2L} = N \times \Delta \nu$$

$$L = 0.42m$$

$$\lambda_0 = 1064nm$$

$$\nu_0 = 282THz$$

$$\Delta \nu = 714MHz$$

$$T = 1.4ns$$

Short laser pulse can be generated by many longitudinal waves which are completely mode-locked.

7psec pulse width requires 200 longitudinal modes in the case of 714MHz repetition rate.

$$\nu_k = \nu_0 + k \times \Delta \nu \quad (|k| \leq m, M = 2m + 1)$$

$$E(t) = \sum_{k=-m}^{+m} E_k(t) = \sum_{k=-m}^{+m} E_0 e^{i2\pi \nu_k t}$$

$$= E_0 e^{i2\pi \nu_0 t} \sum_{k=-m}^{+m} e^{ik 2\pi \Delta \nu t}$$

$$= E_0 e^{i2\pi \nu_0 t} \frac{\sin(M \pi \Delta \nu t)}{\sin(\pi \Delta \nu t)}$$

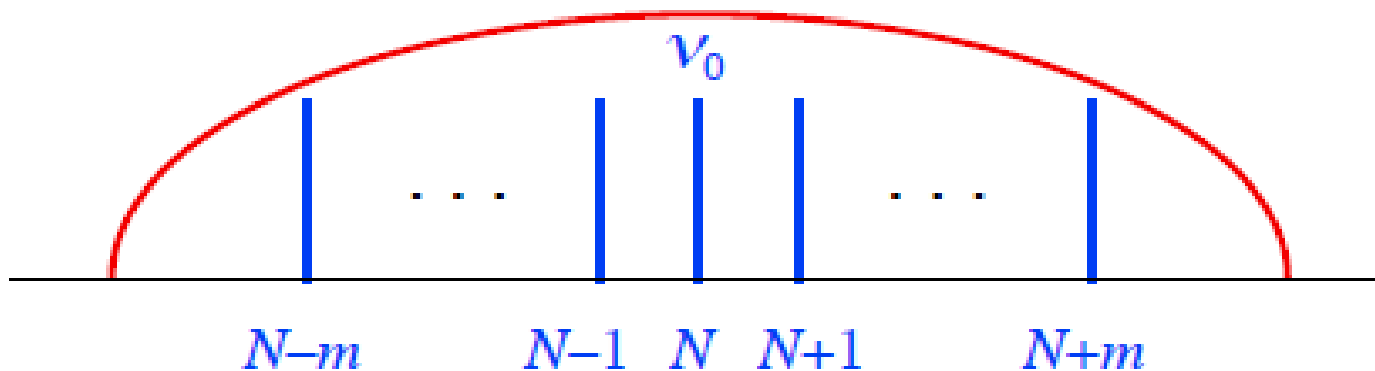

Check by Mathematica in my laptop computer

Cavity Length =420mm, Center of the Cavity is $z=0$. Two 7psec laser pulses are moving upward and downward from high reflective Mirrors at $t=0$.

710.000762psec later

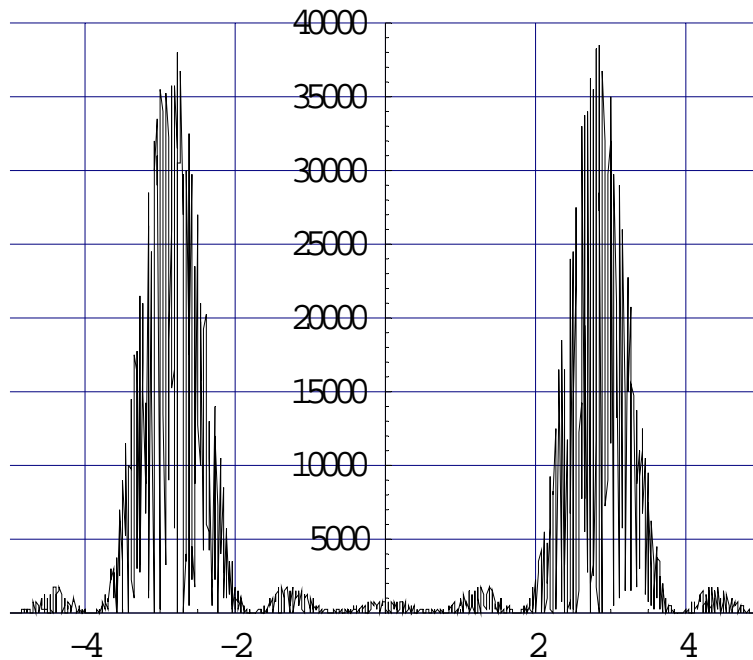

705.000762psec later

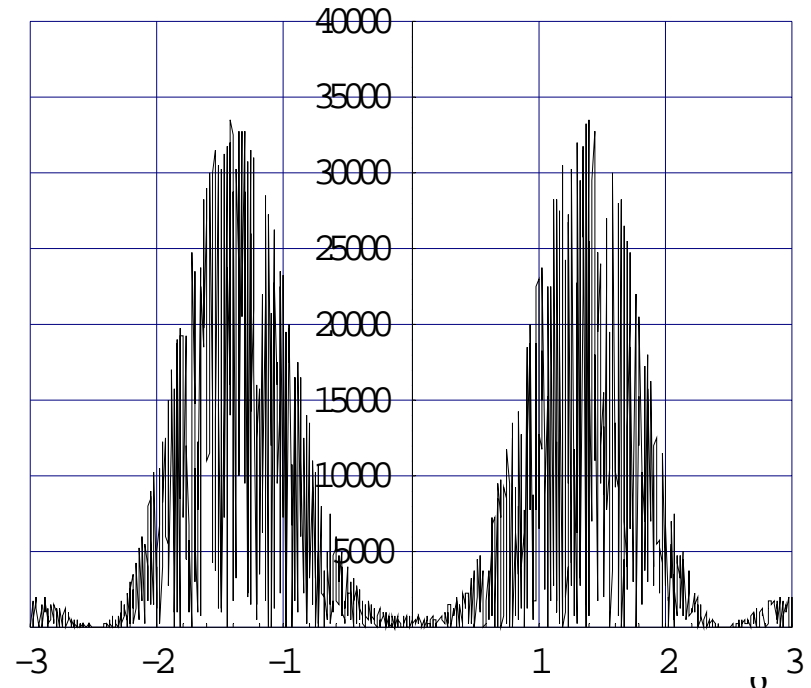

Interference

700.00076psec later

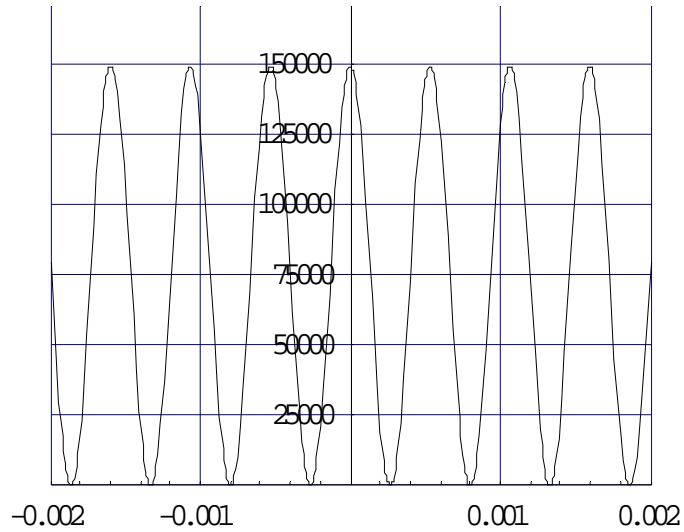

700.002psec later

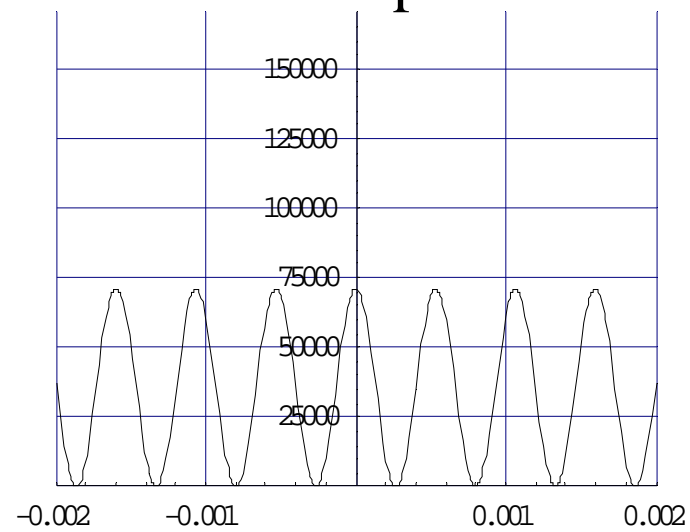

700.003psec later

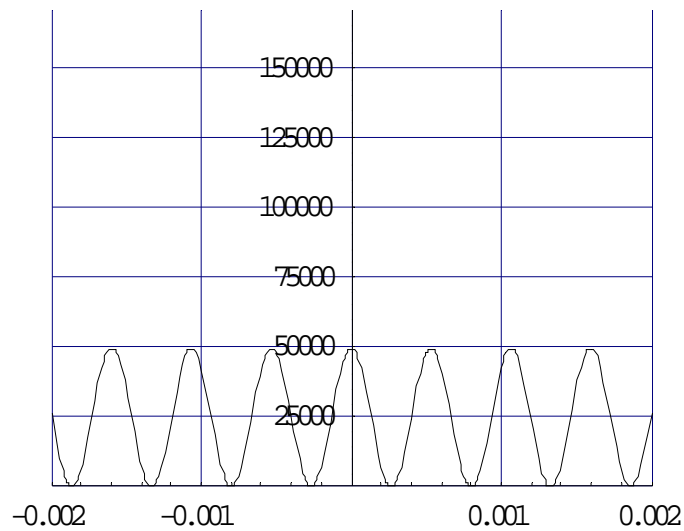

700.0033psec later

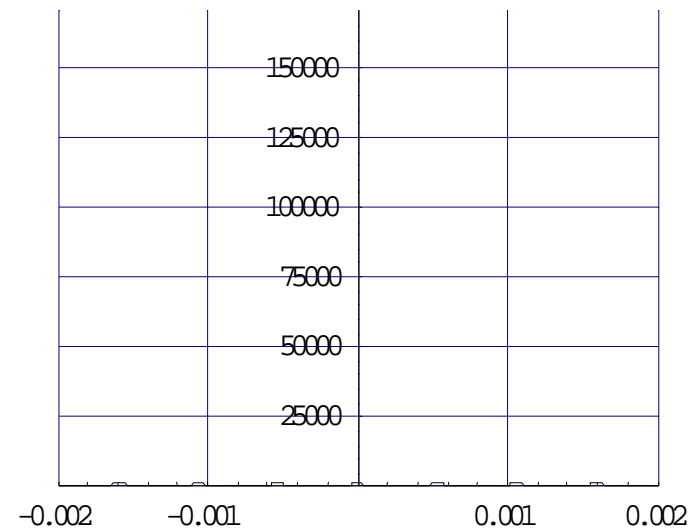

3. Plan of Test Experiment

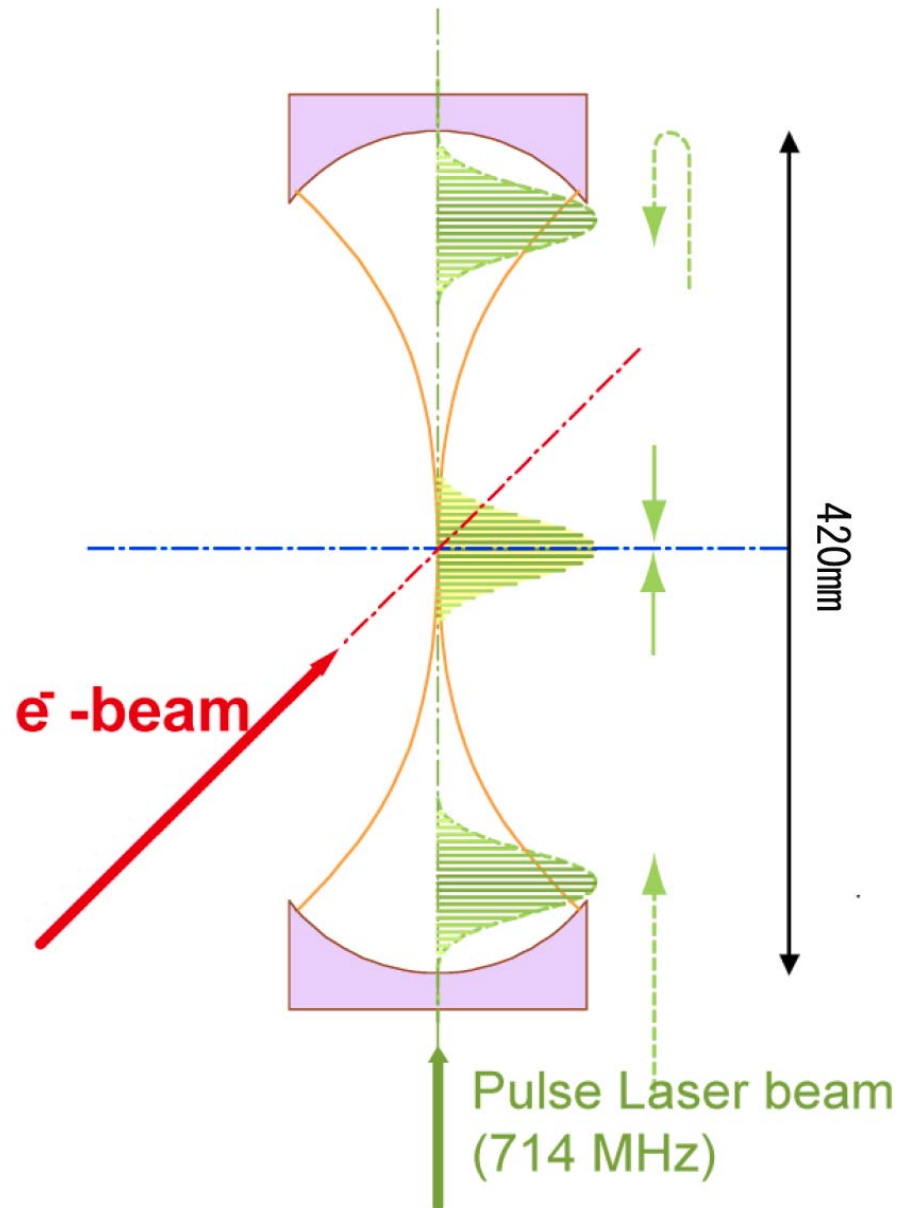

Specification of the 357MHz mode-lock laser

10W, 7psec pulse width(FWHM)

0.02psec(rms) timing jitter? Less than 0.001fsec within 1msec period.

First step : Confirmation of Interference (Using 714MHz mode-lock laser with power of 800mW)

Second step : Movement of the Interference by phase shift

Third step : Installation into ATF2 near IP

Cavity interferometer

Principle of the beam size measurement is same as Shintake monitor.

Two laser beam of the opposite direction produces a standing wave.

Cavity case, two pulses have to be stored in the Cavity.

Advantage

Overlap of the two beams is perfect (the cavity's transverse mode).

Time overlap can be precisely measured using transmission light.

We can control of the position of the interference fringe pattern.

Disadvantage

Laser power

>10W laser source and high finesse (10,000) cavity is needed.

Stability of the cavity (and Laser).

Quiet environment and fast control.

Fringe scanning

Cavity stores two pulses

laser's rep. rate has to be x2 of the cavity's round trip time

Rep. rate doubling using a delay line scheme enables us to do fringe scan/control

The cavity transmission laser pulse can be used.

Monitor intensity balance of two pulses in the cavity

Pulse spacing (fringe position) of two pulses

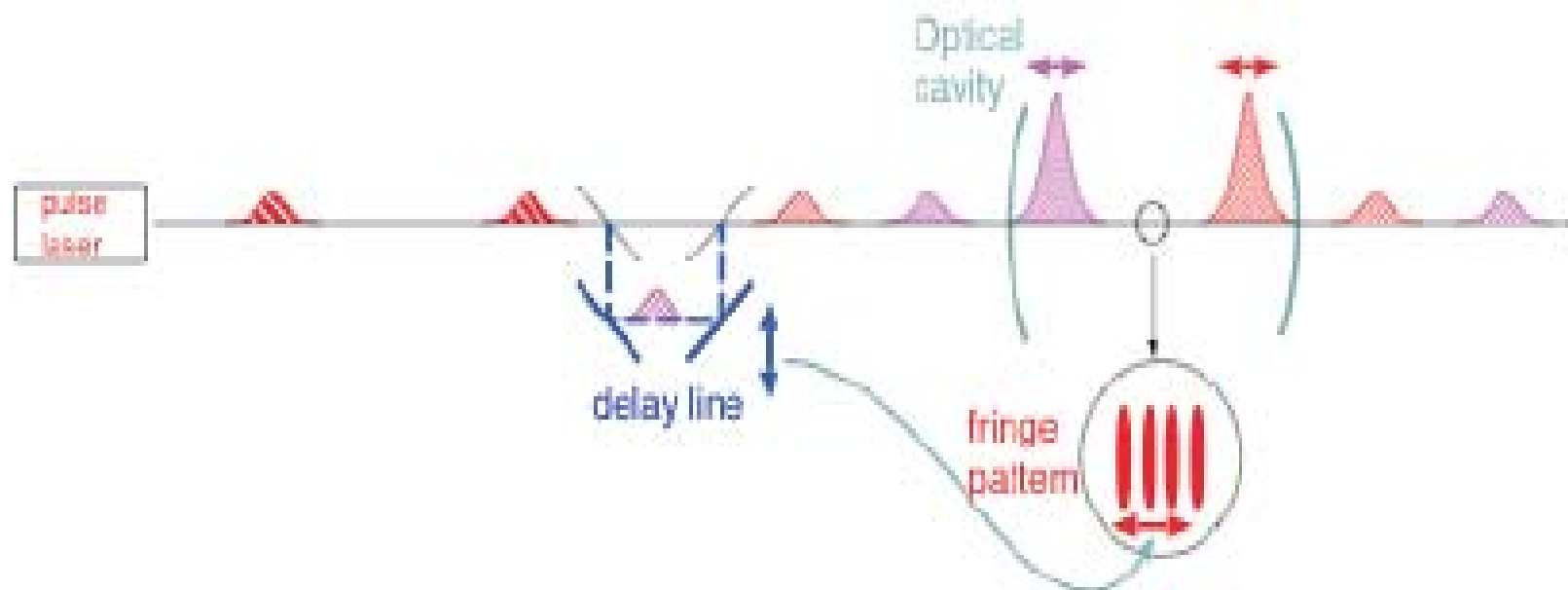

Fringe position and beam orbit measurement

Position of one of the cavity mirror is a good reference of fringe position at the cavity

A cavity BPM will be contained in the interaction chamber

Relative position of the cavity mirror and the BPM will be monitored by a laser interferometer

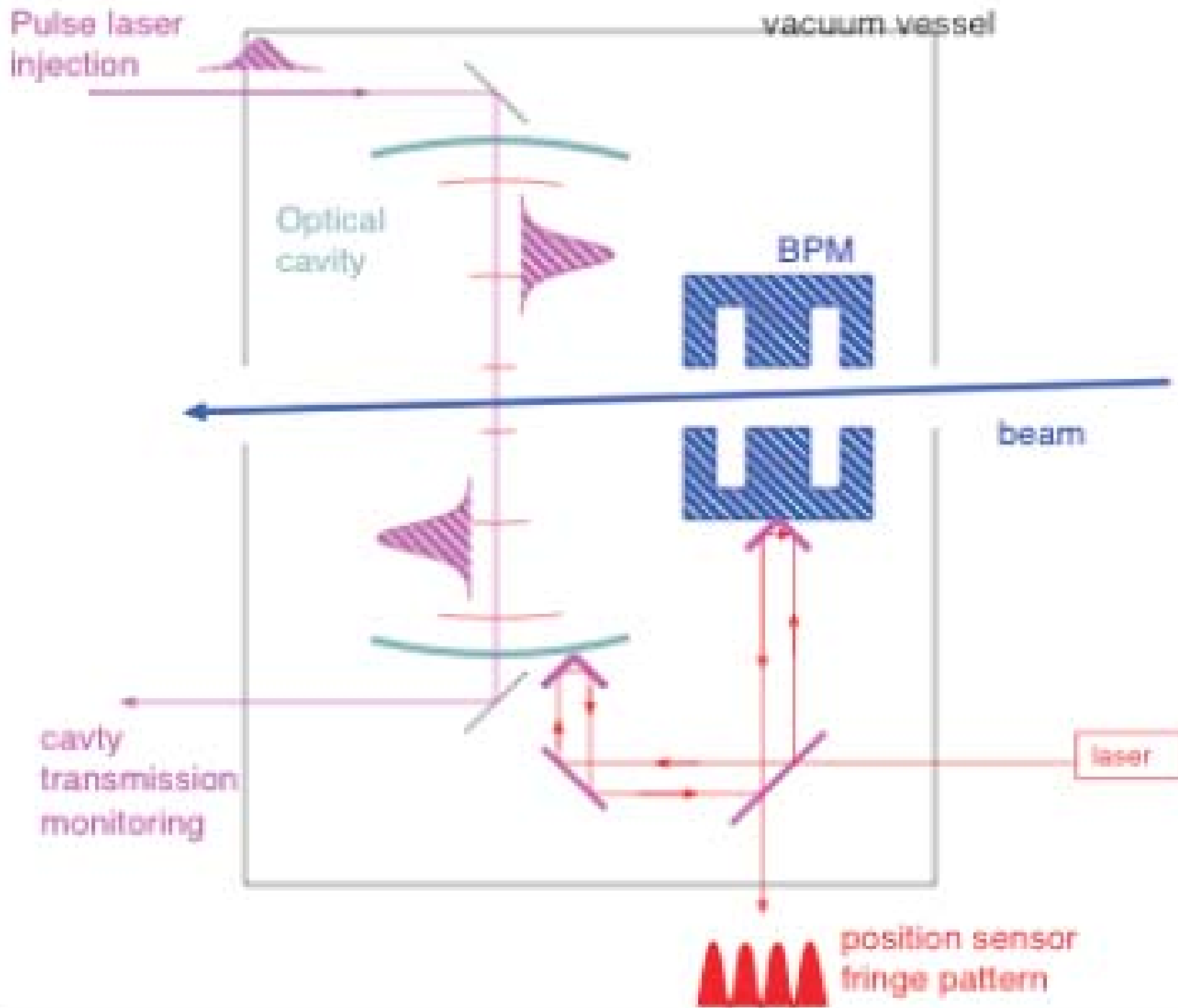

Control system

Three control loops

Synchronize laser source to electron beam

Lock cavity resonance

Fringe position control

タイミング制御 (Timing Control)

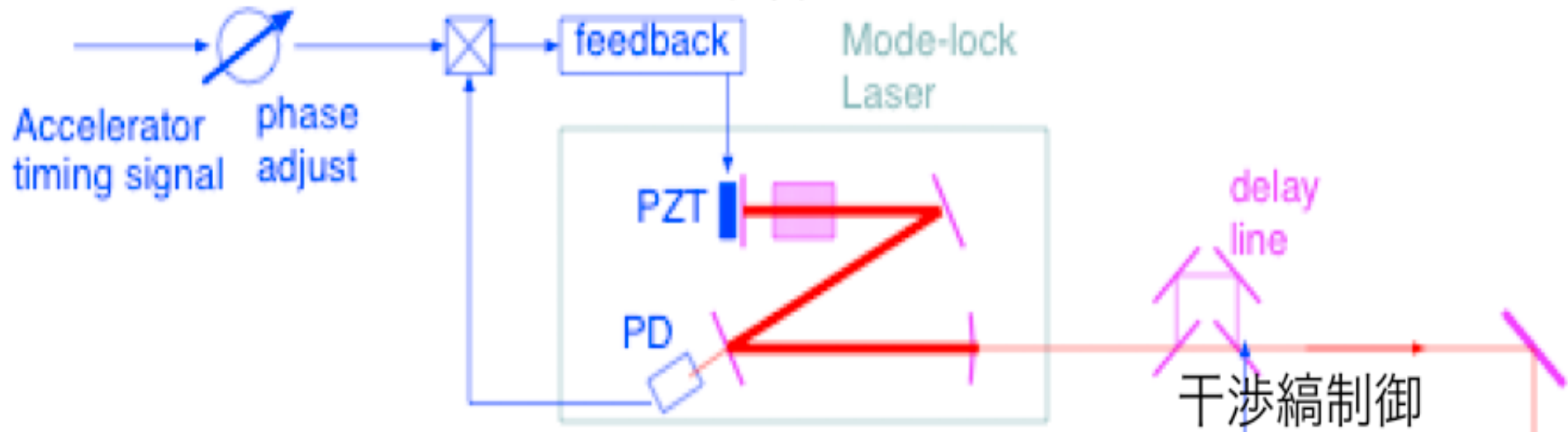

(Control of Interference Fringe)

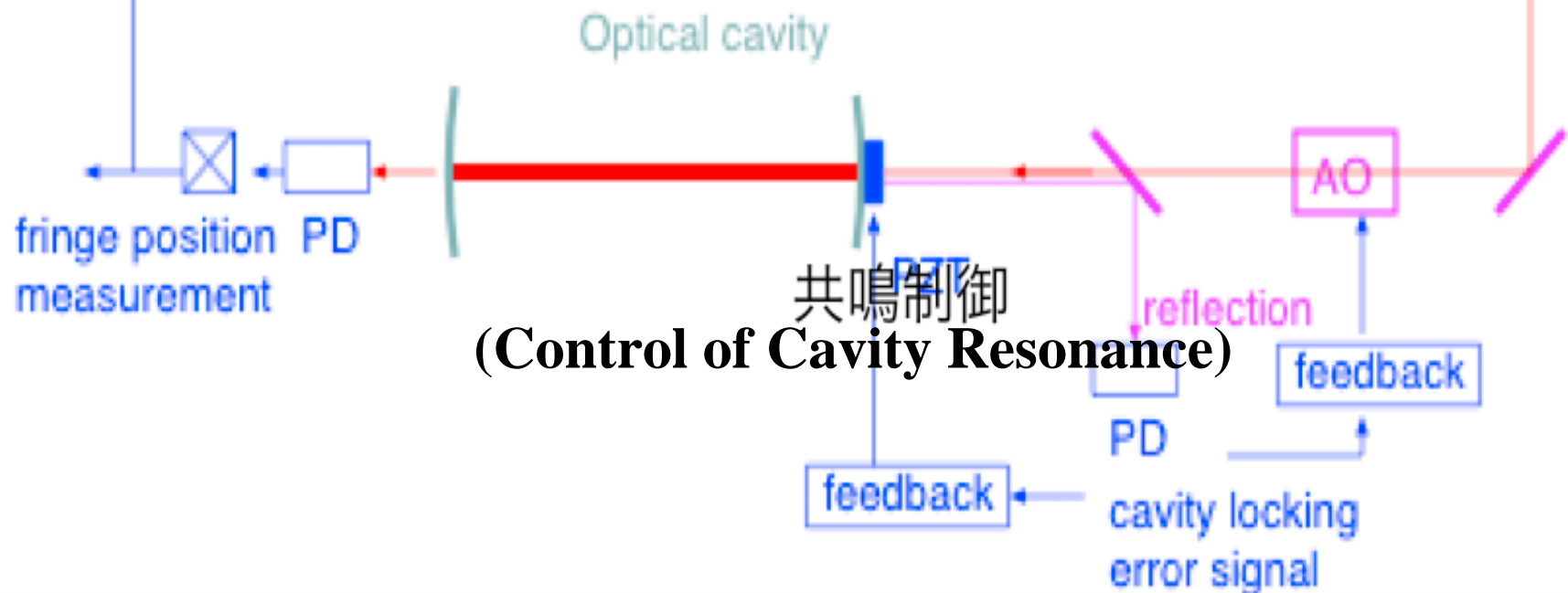

(Control of Cavity Resonance)

We are ordering 357MHz, 10W Mode-lock laser in this year, hopefully next year 20W same type will be ordered.

Assuming 3.0 μm horizontal beam size, laser waist size of 20 μm at IP, 357MHz-10W mode-lock laser, optical cavity enhancement 10,000 and beam orbit without angle jitter, following counts per collision are Calculated. It shows the measurement of 30nm beam is possible.

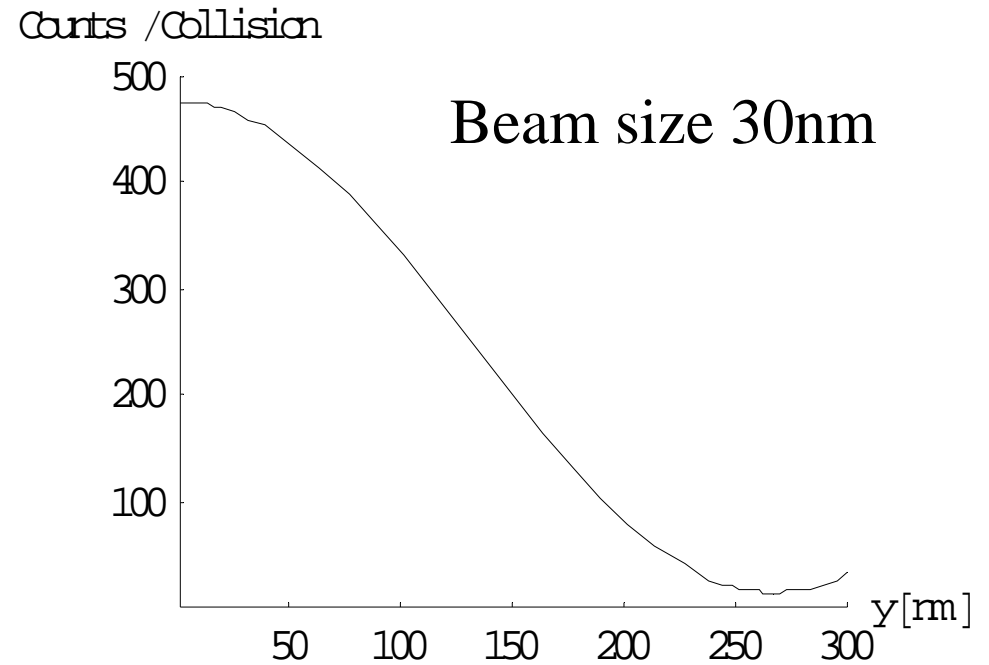
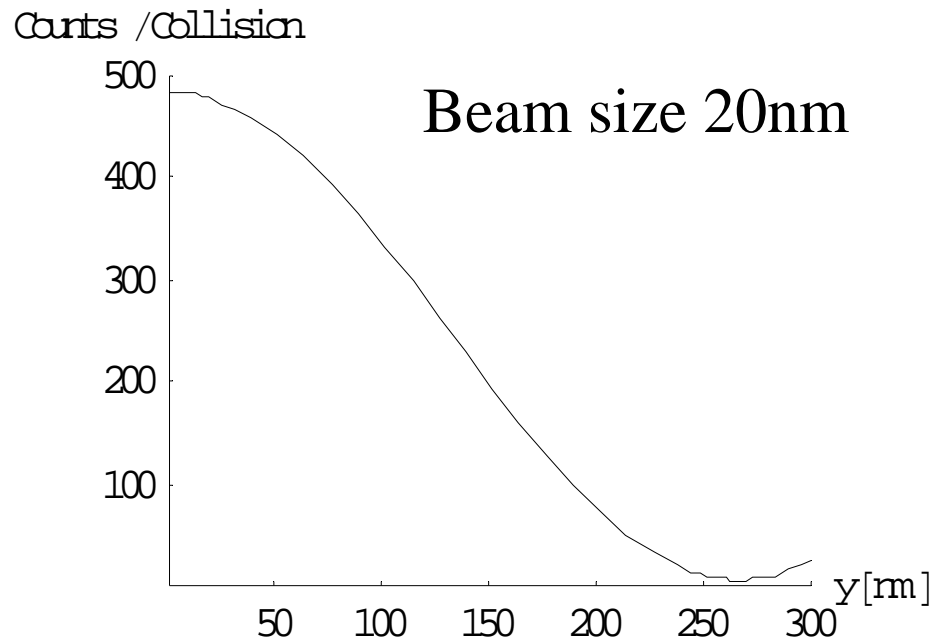

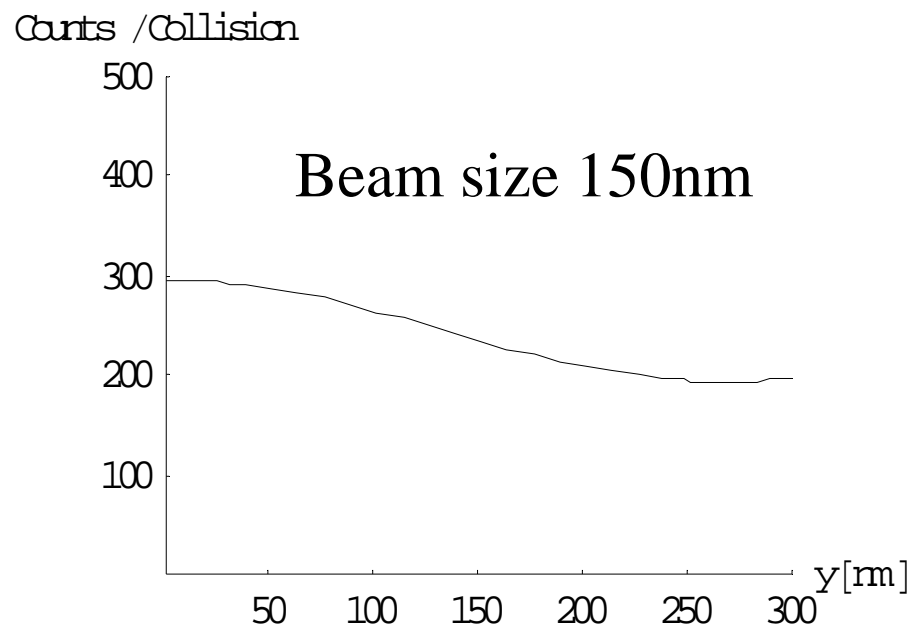
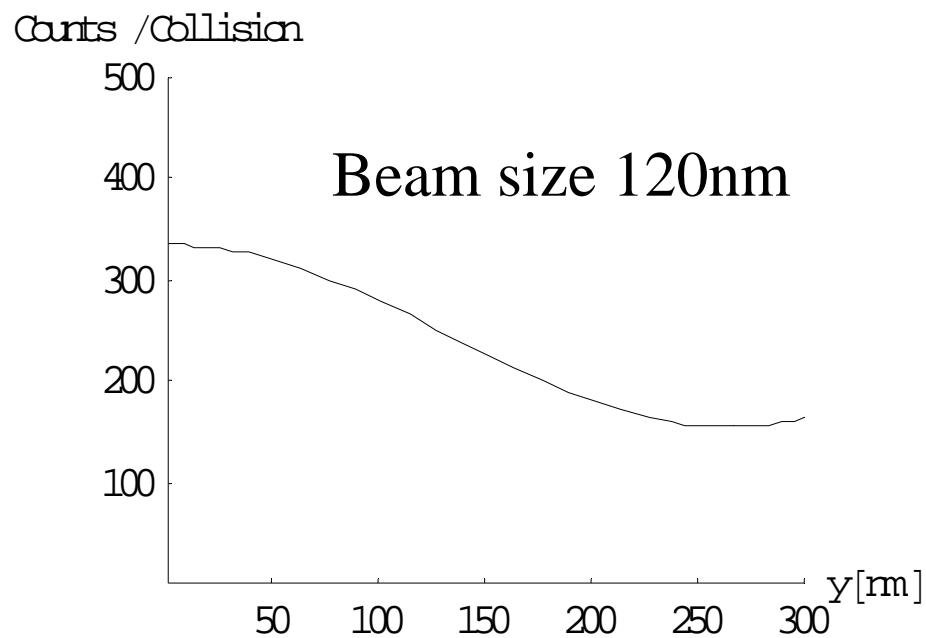
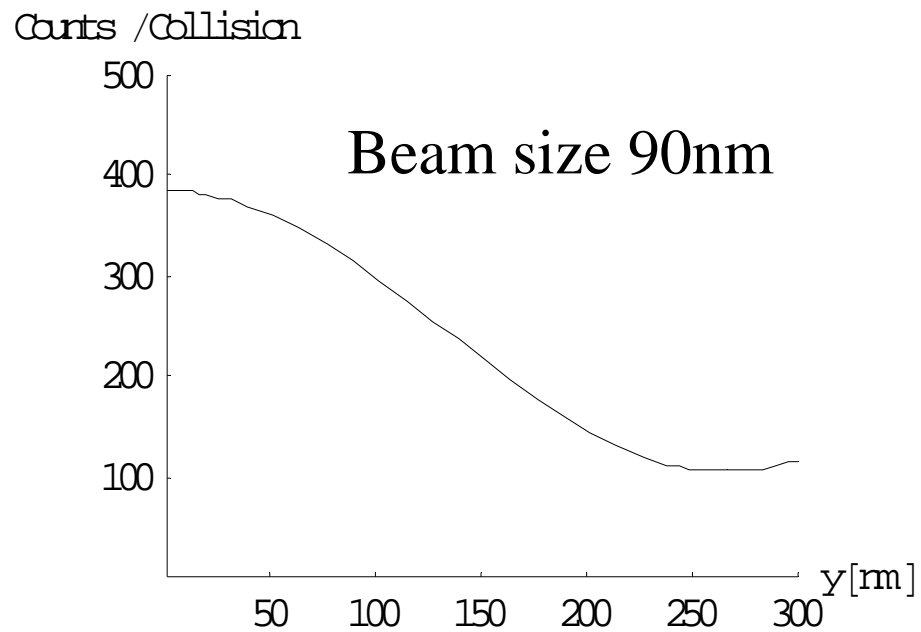
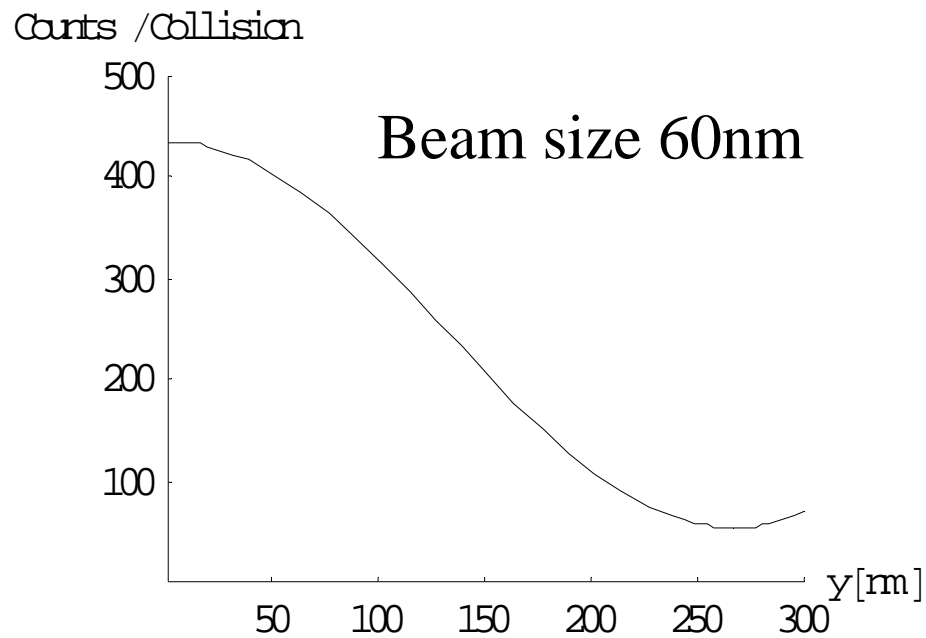

4. Plan of Test Experiment

We started the manufacture of 0.42 m length two optical cavities with precise feedback system from Jan. One is for X-ray generation experiment as LUXC project. (Ref. Sakaue's talk.)

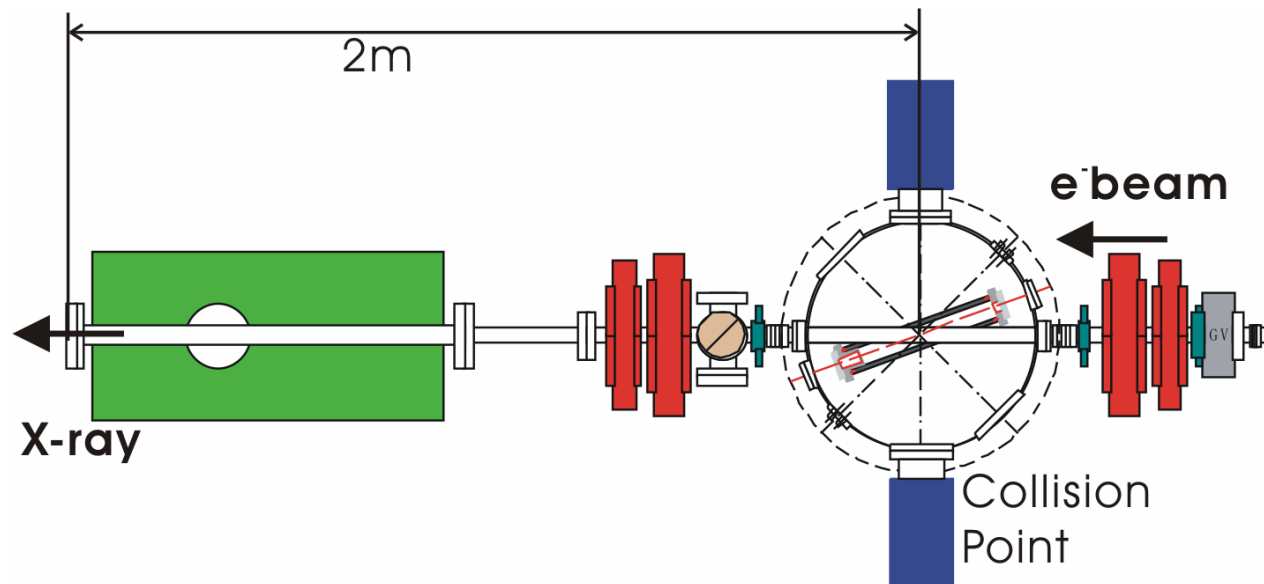

Another is for γ generation as Posipol project.

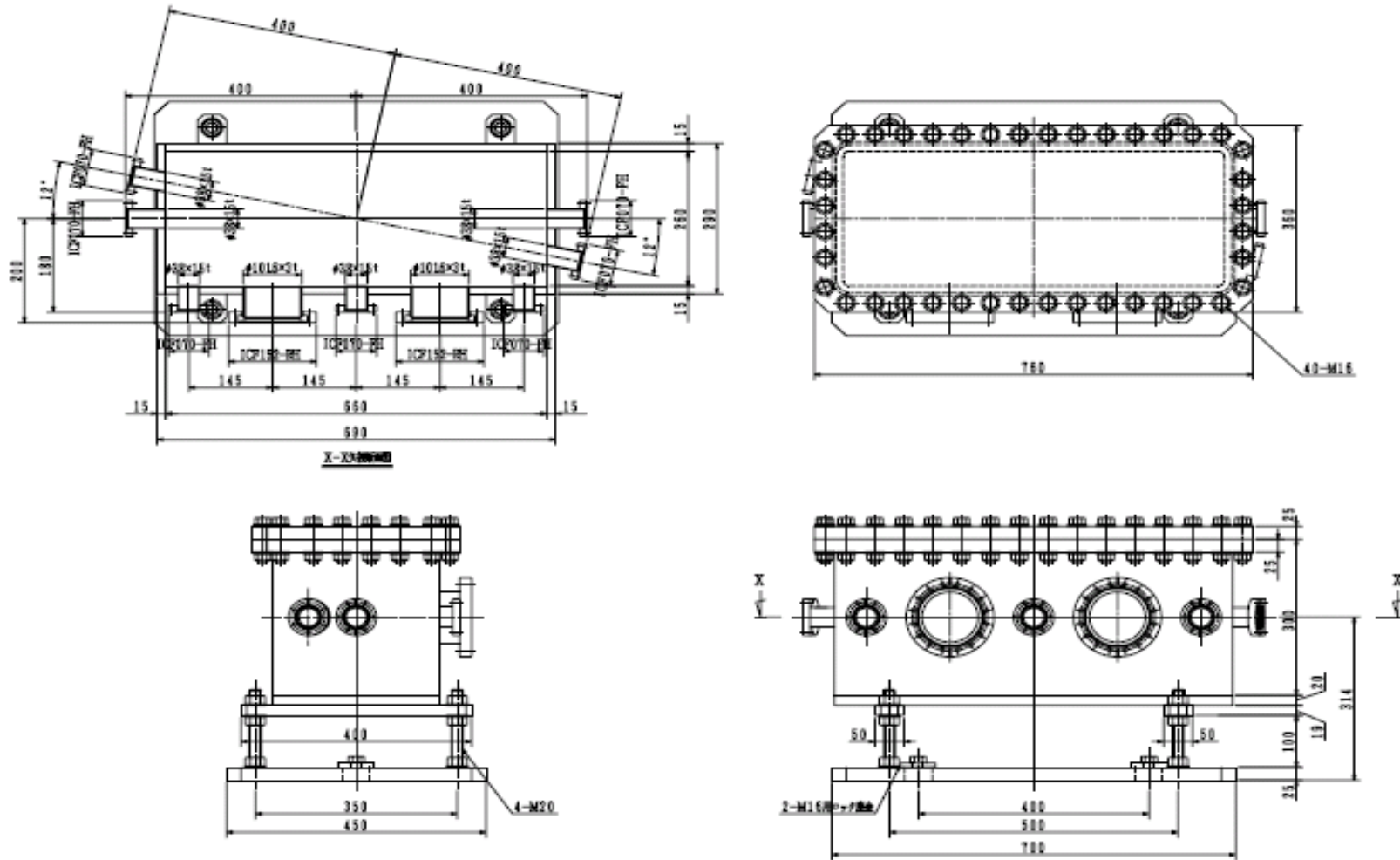

We will install this device into DR during summer Shutdown, hopefully this Oct.. (Ref. talk of Okugi?)

5. Future plan

- We will design the chamber which includes vertical 42cm optical cavity and is attached with upstream cavity BPM and downstream cavity BPM. Two BPMs can measure the beam orbit within the accuracy of a few nano-meter.
- This is a backup system for Shintake monitor which is prepared by University of Tokyo and ongoing.