

How to open the detectors?



Klaus Sinram
28.02.2019

ILD Structure

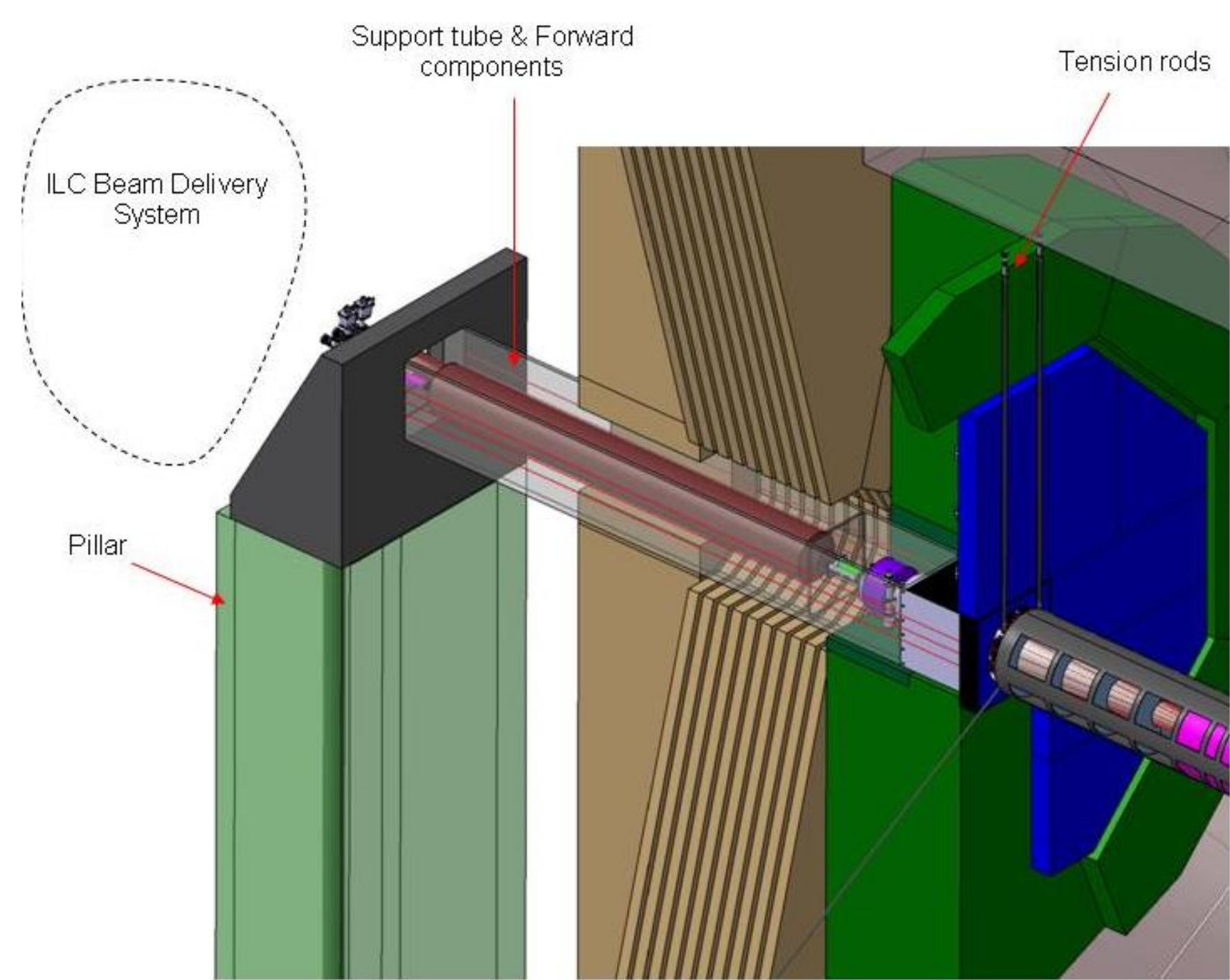
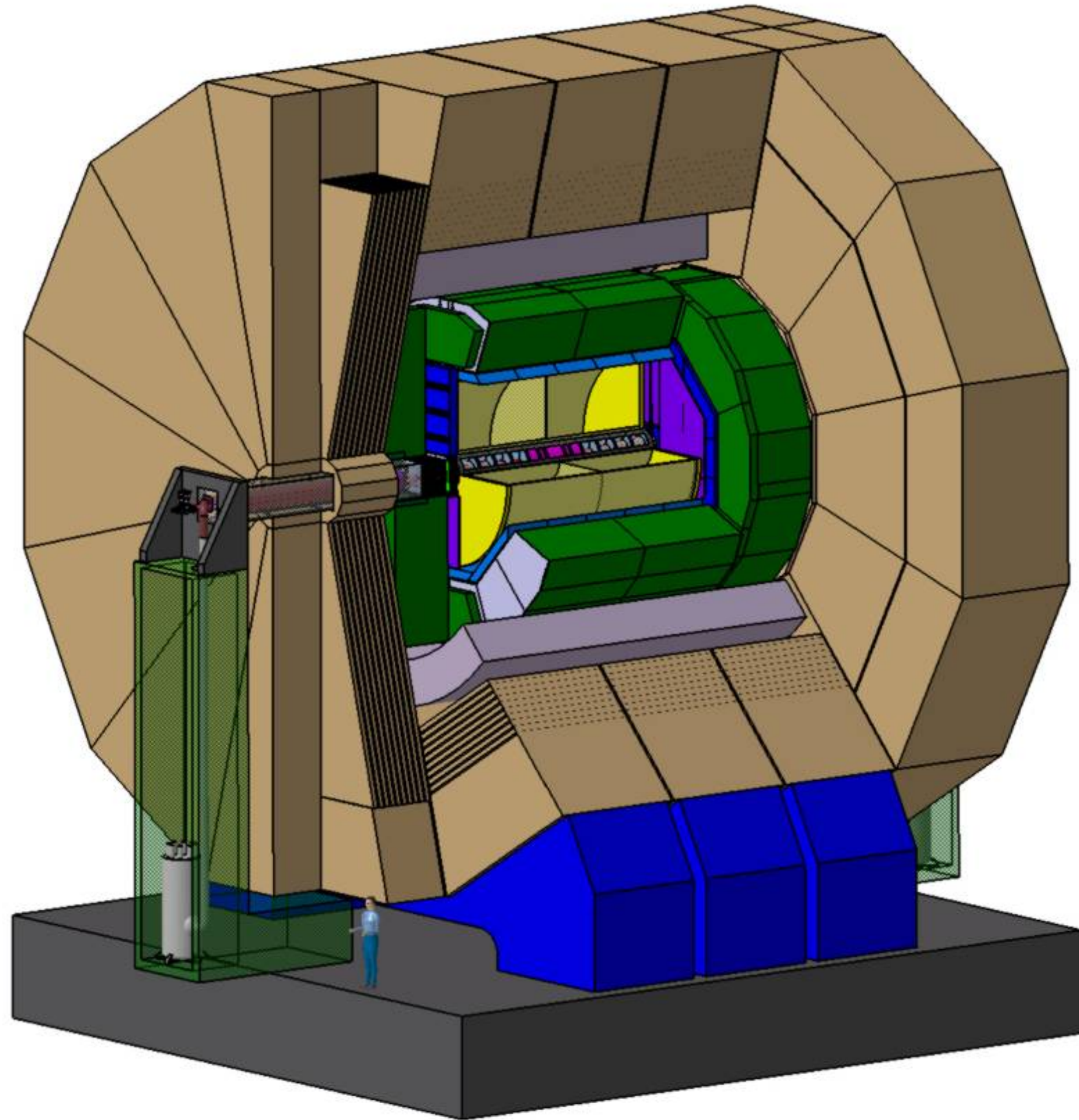
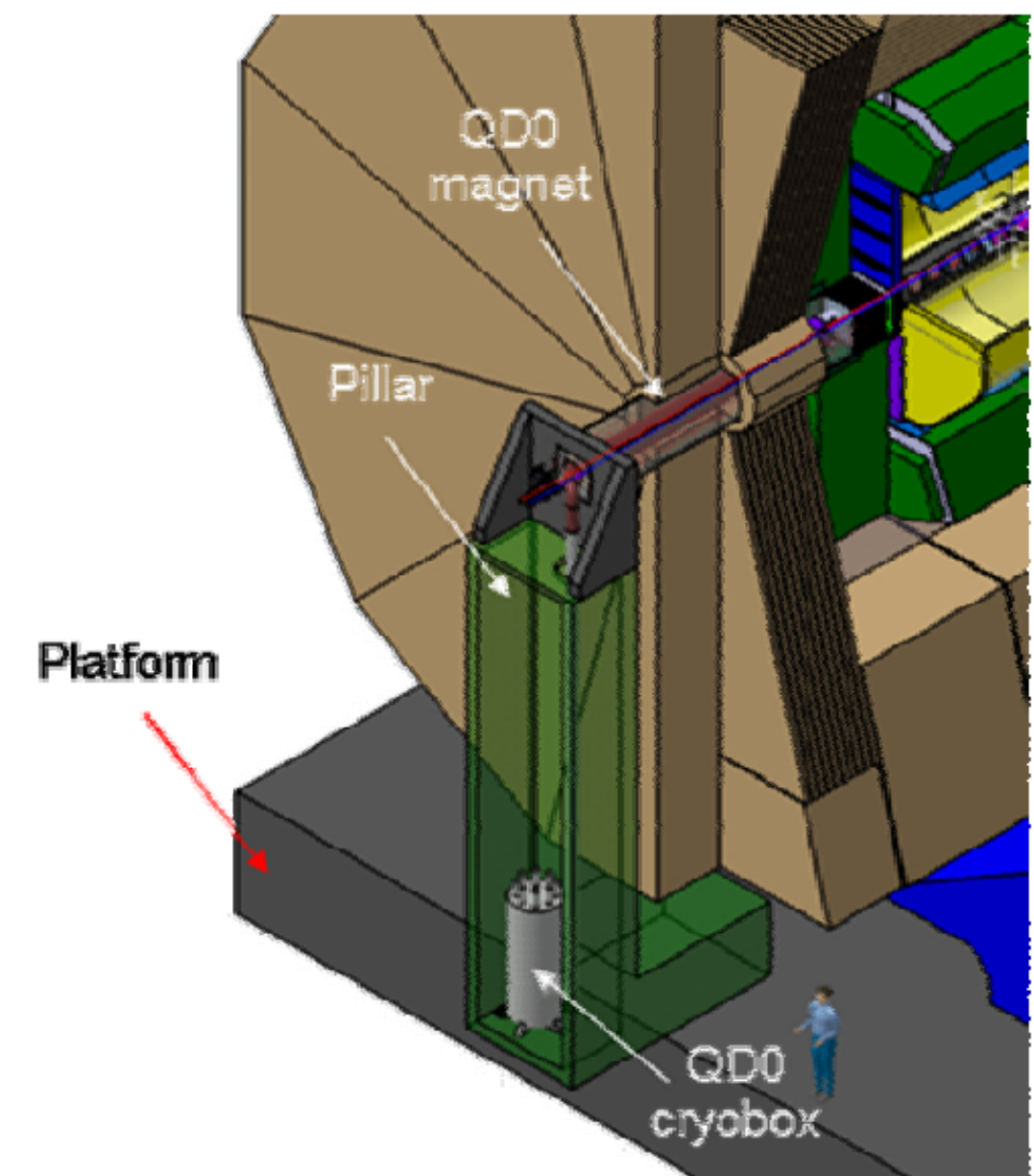
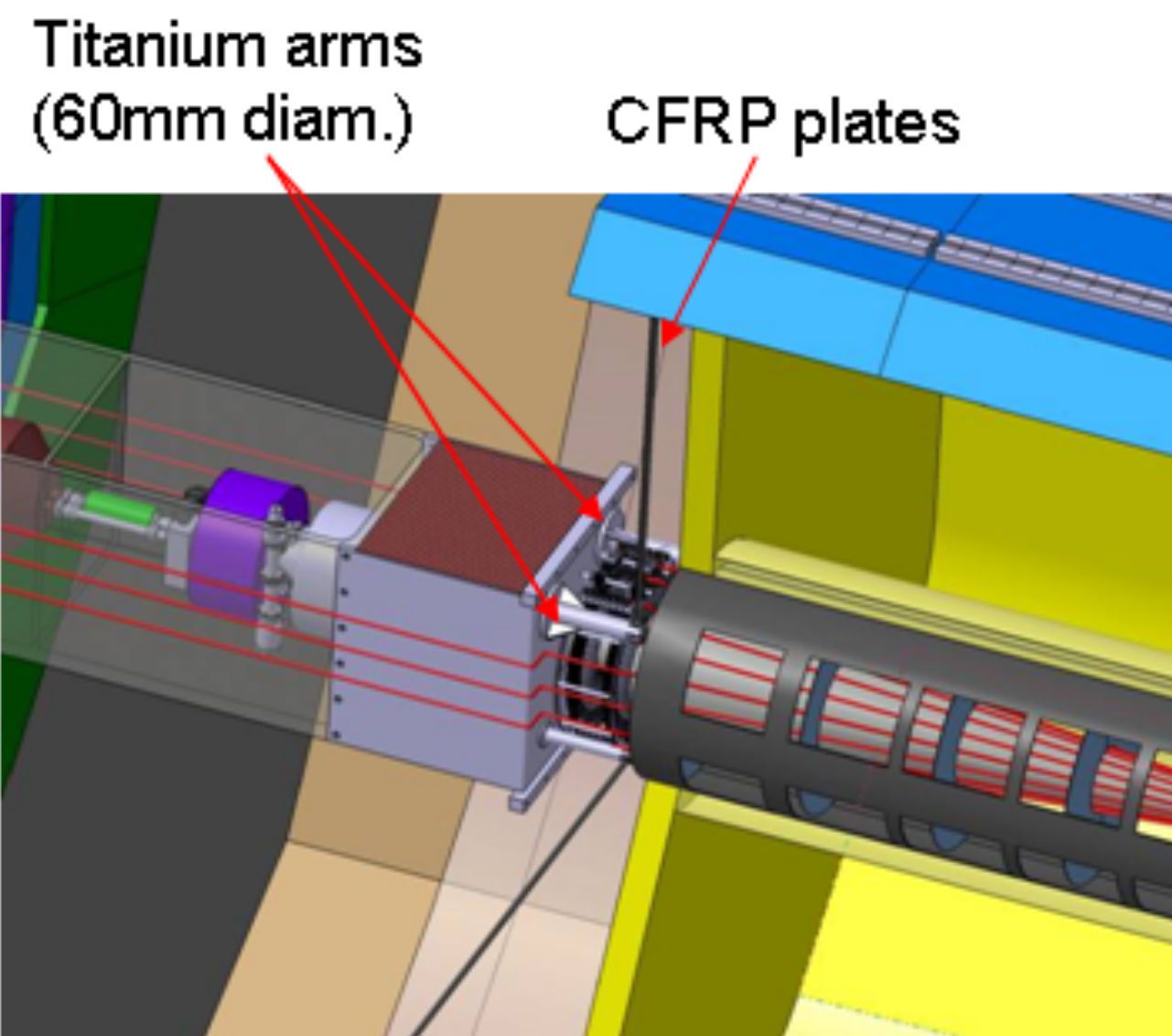
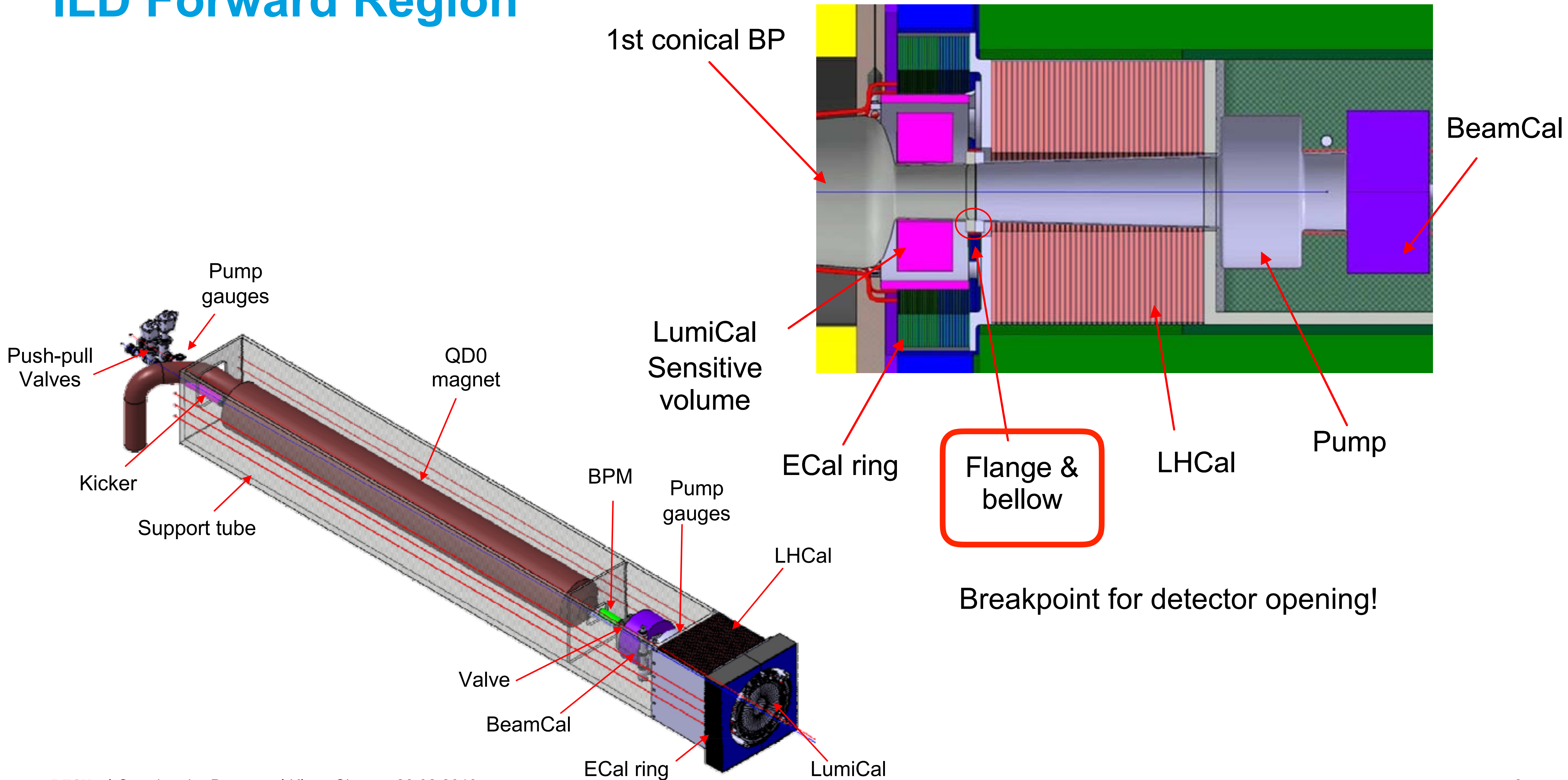

FIGURE 2.4.2.1 Support tube



ILD Forward Region



ILD - Opening Procedure

ILD opening procedure has been suggested 10 years ago

- „Note on the Integration of the ILD Detector“, C. Clerc, M. Joré
- Pillar that supports QD0 is limiting the space along the beamline
- With „split endcap“ opening space of ~1m

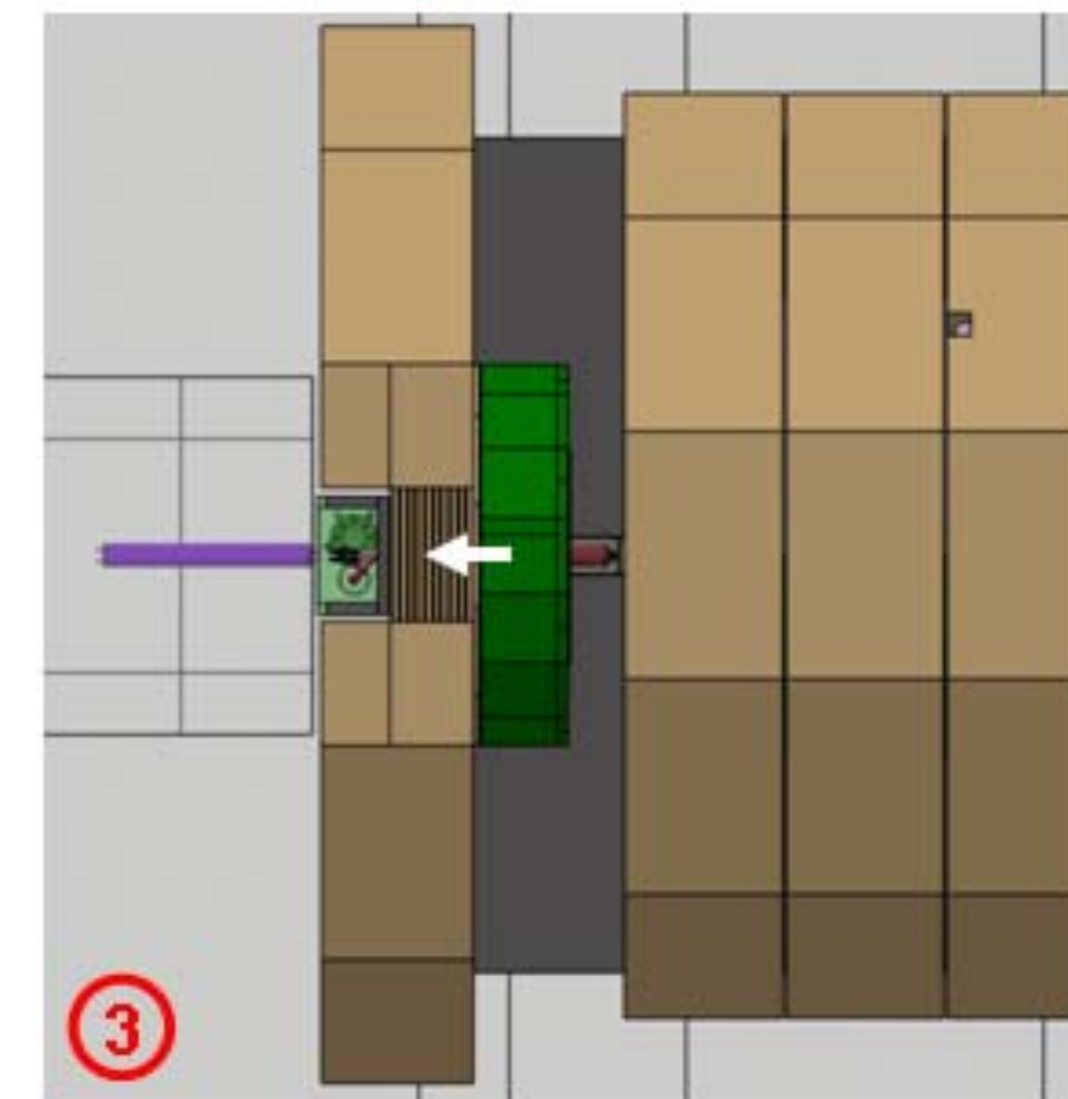
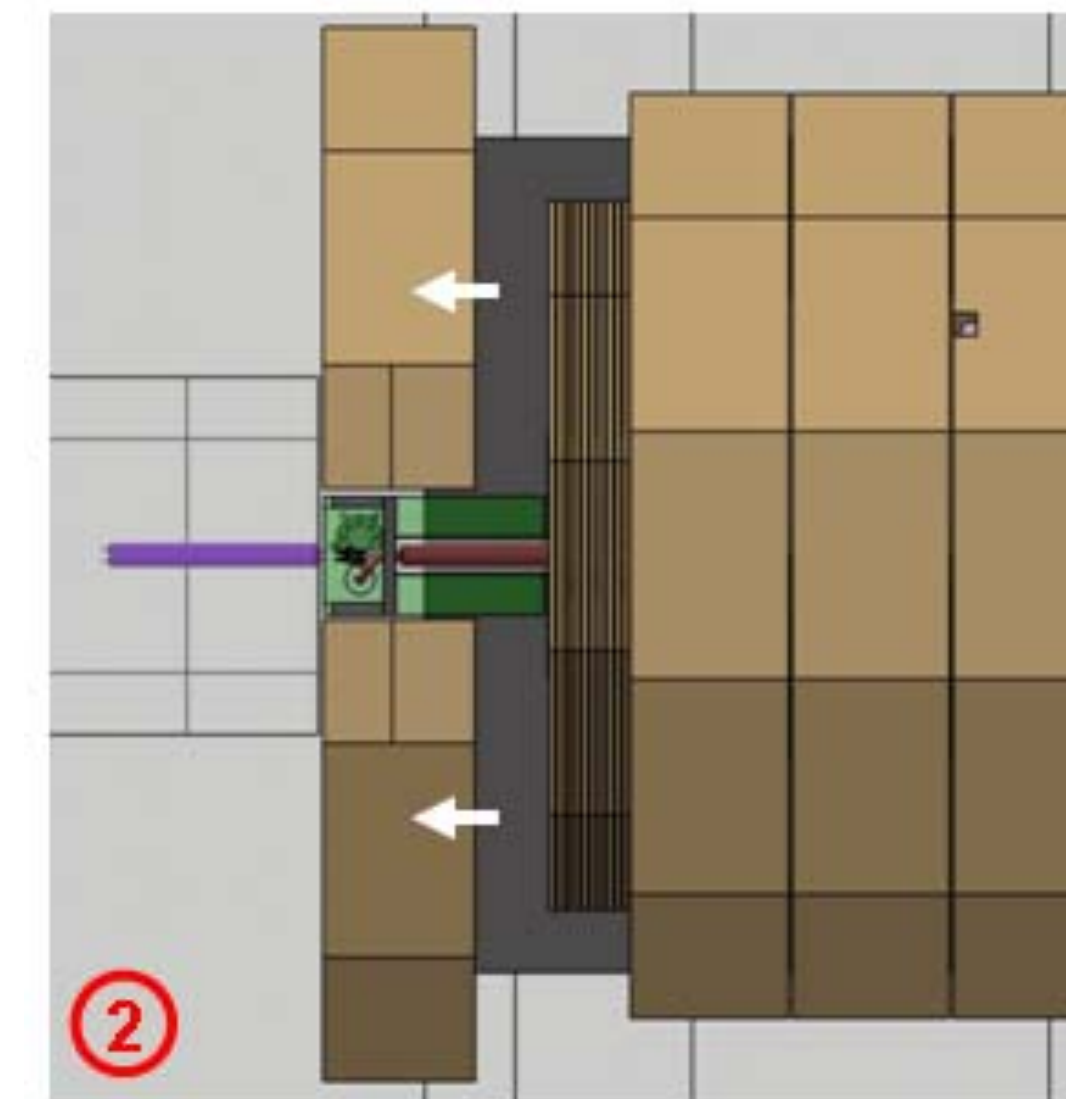
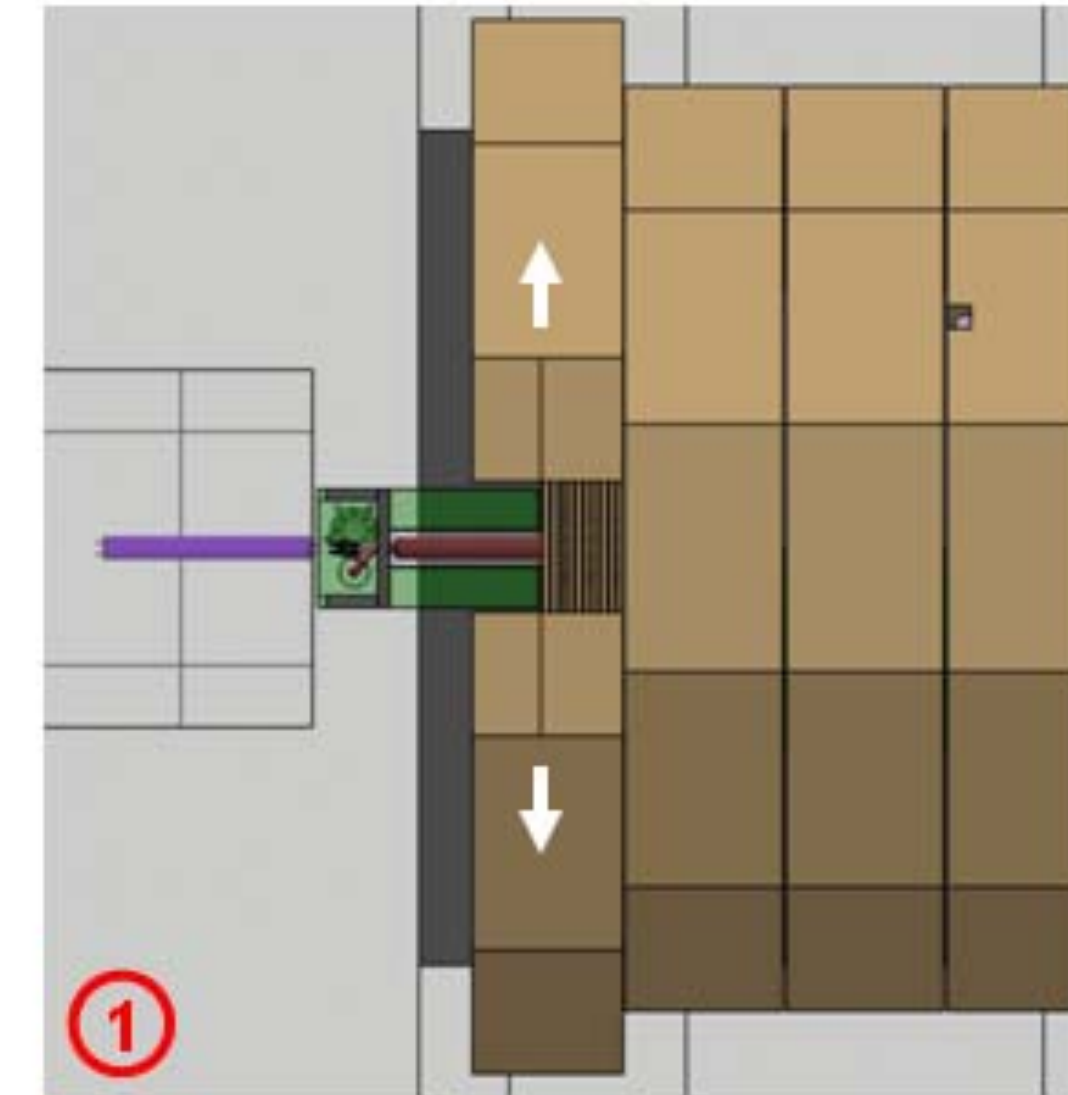
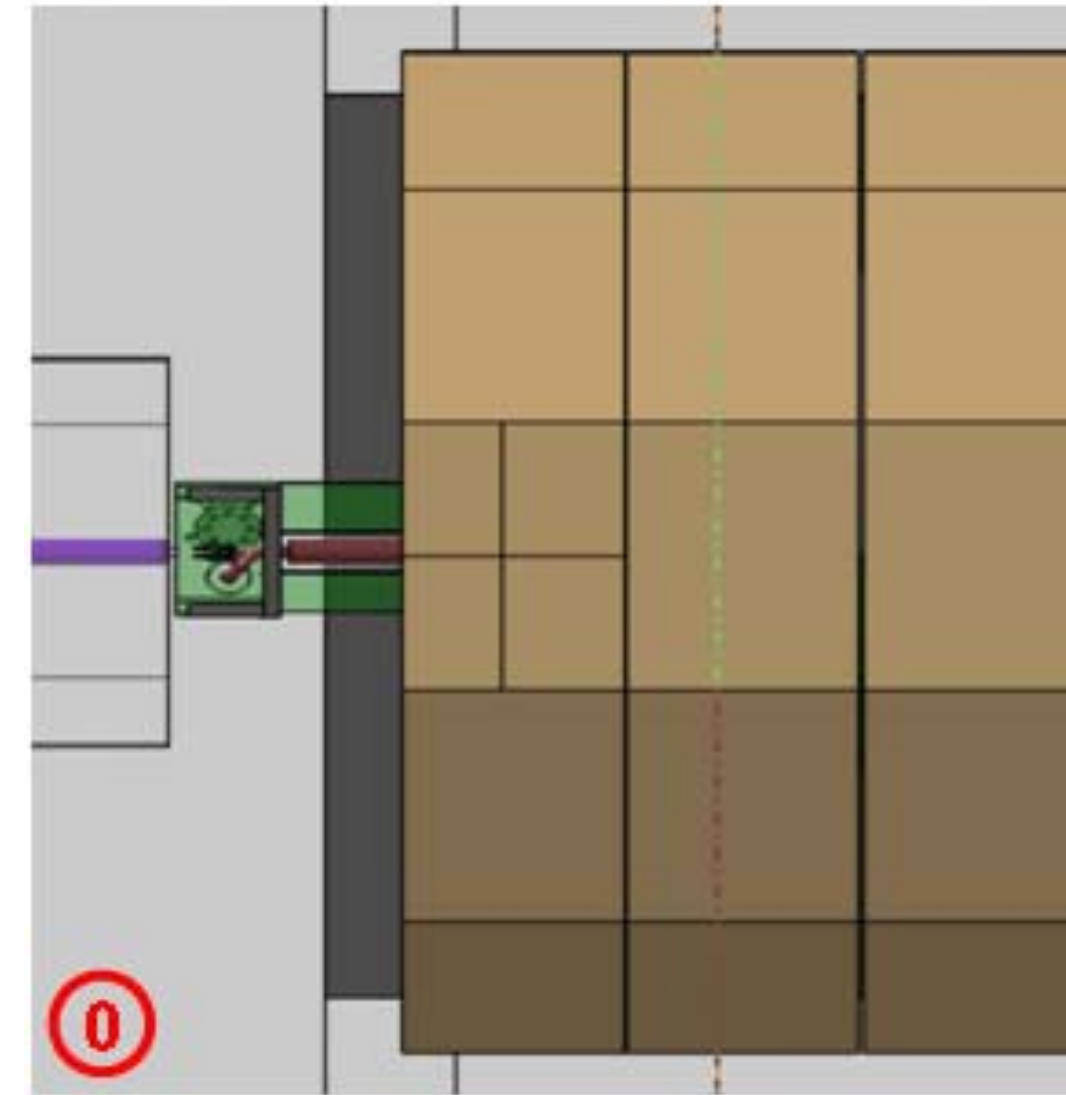
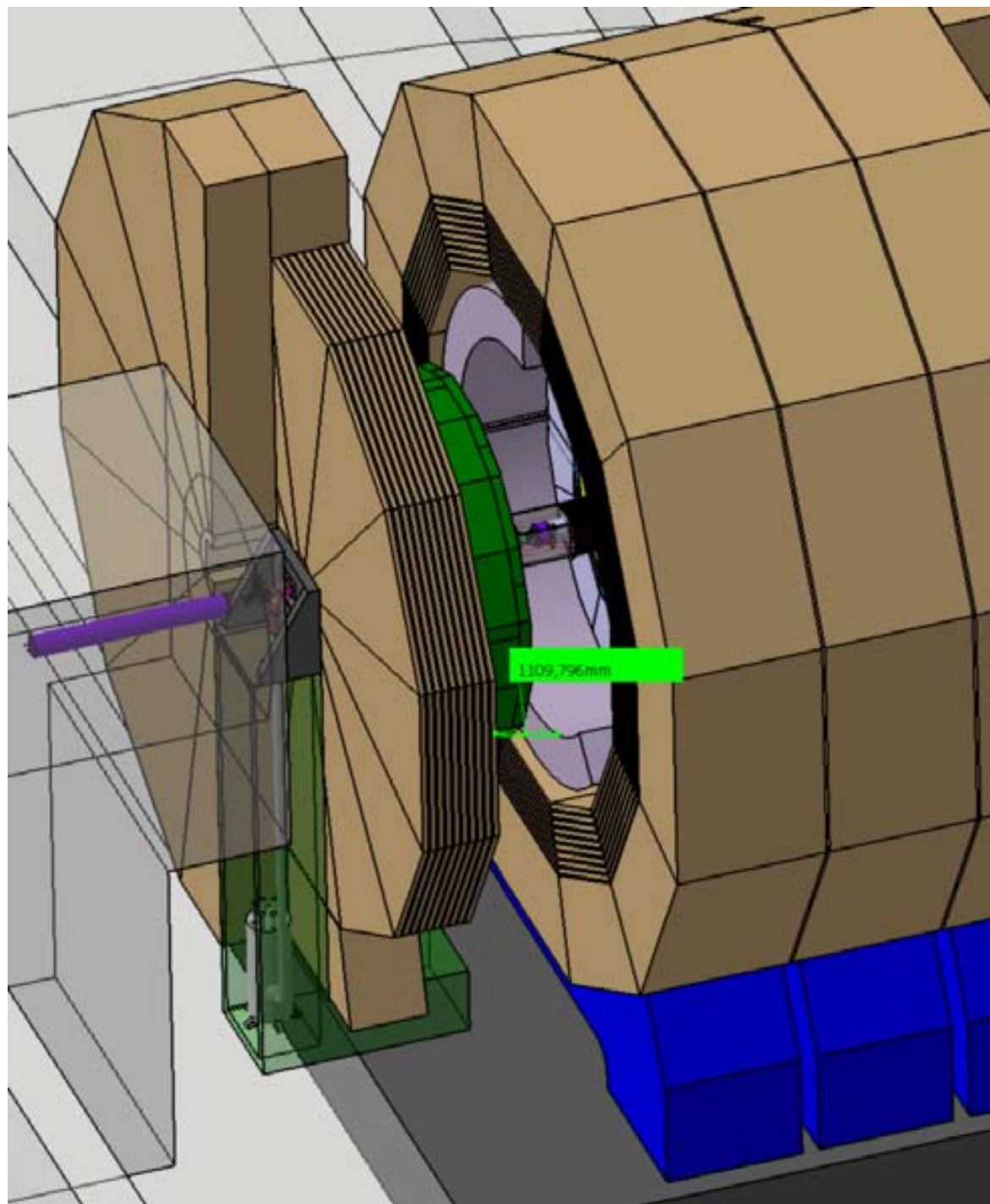

Opening the Flange

Procedure:

- Enter detector through ~1m gap
- Install tooling on cryostat to support QD0/FCAL structure
- Remove ECAL Ring with temporary crane
- Remove tension rods
- Remove LumiCal
- Open Flange

Problems:

- Missing valve (otherwise break vacuum)
- Access space is probably too small
- Unclear how to handle heavy parts in very limited space

Should review QD0 support

- Pillar is an obstacle
- Maybe find better solution

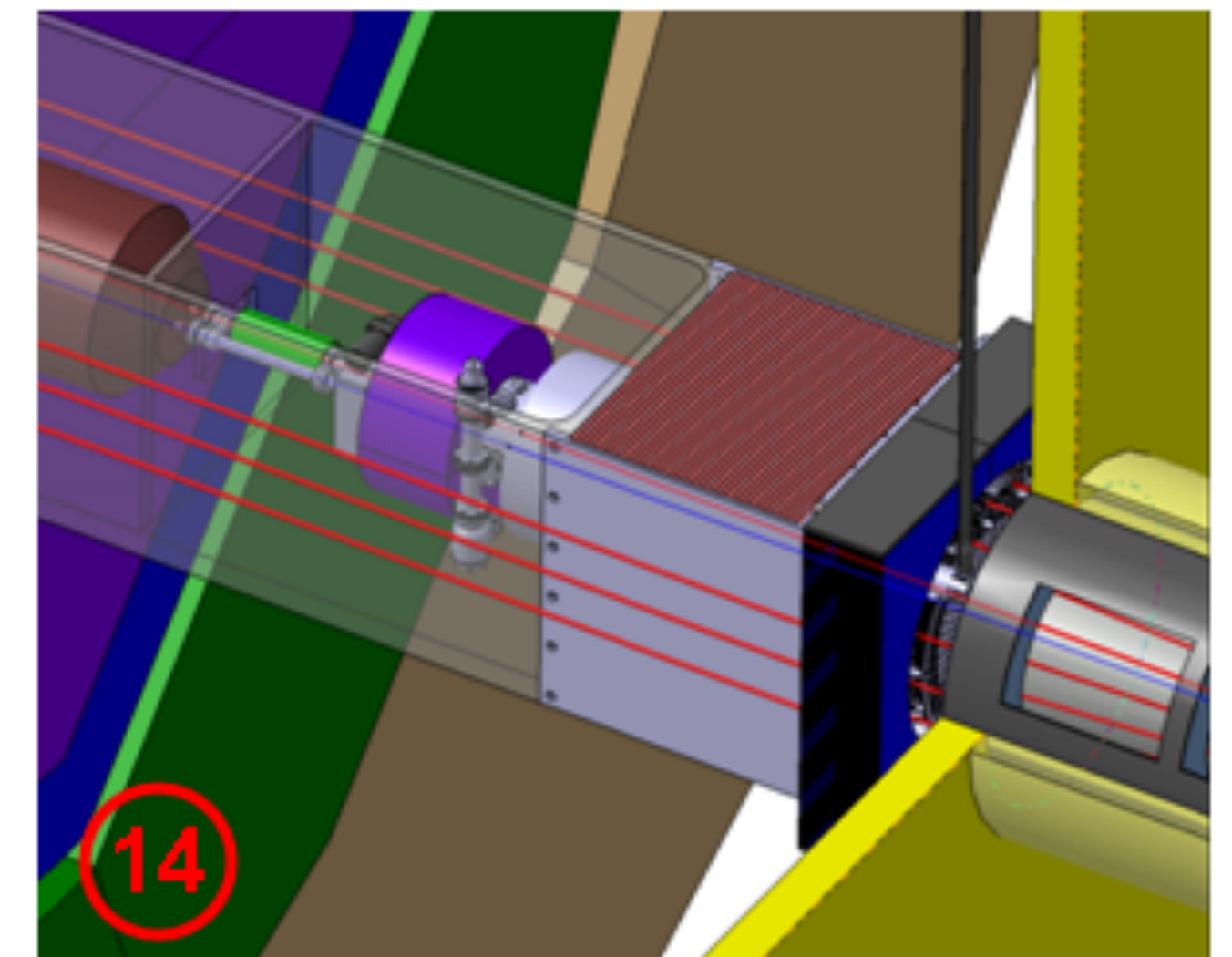
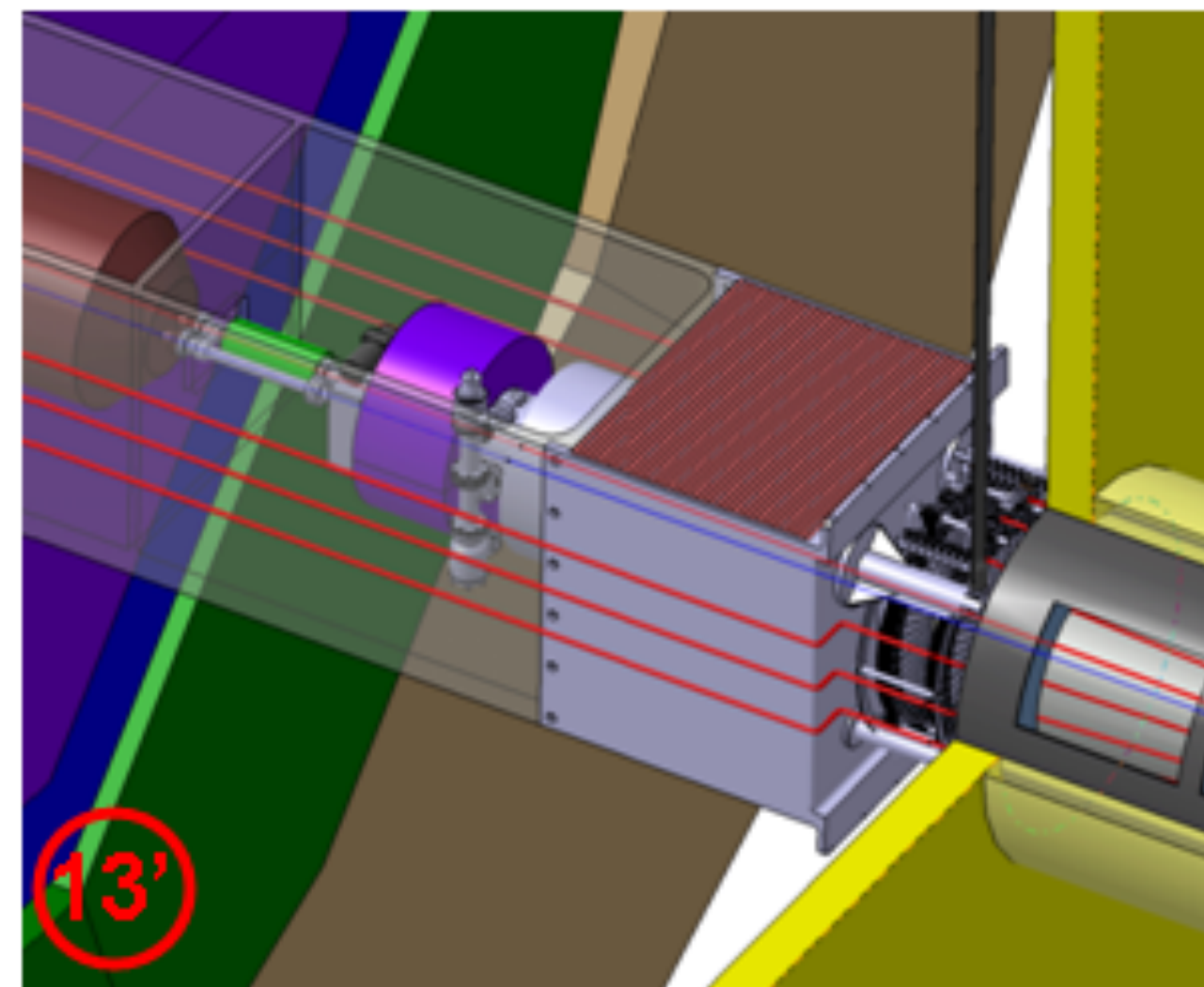
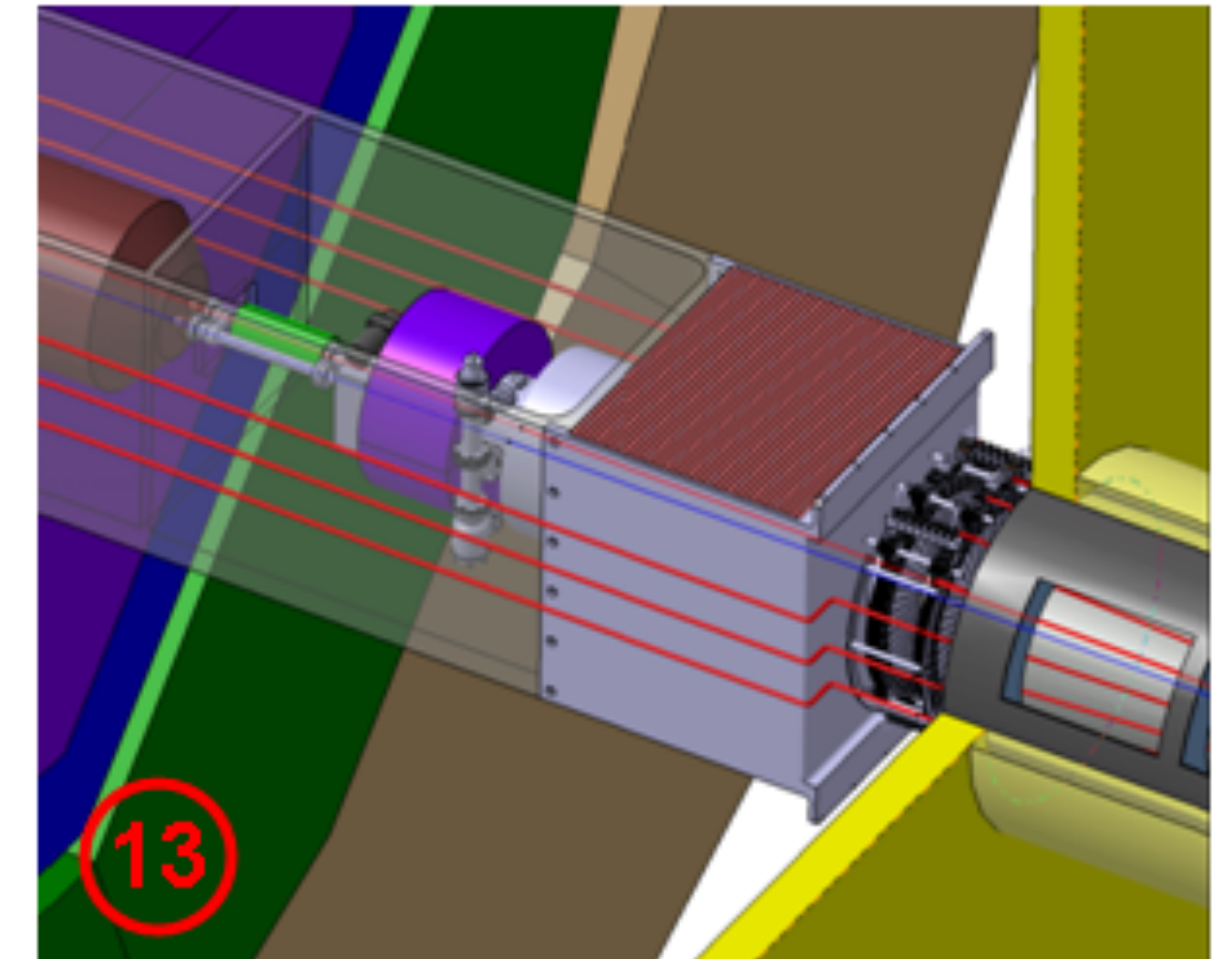
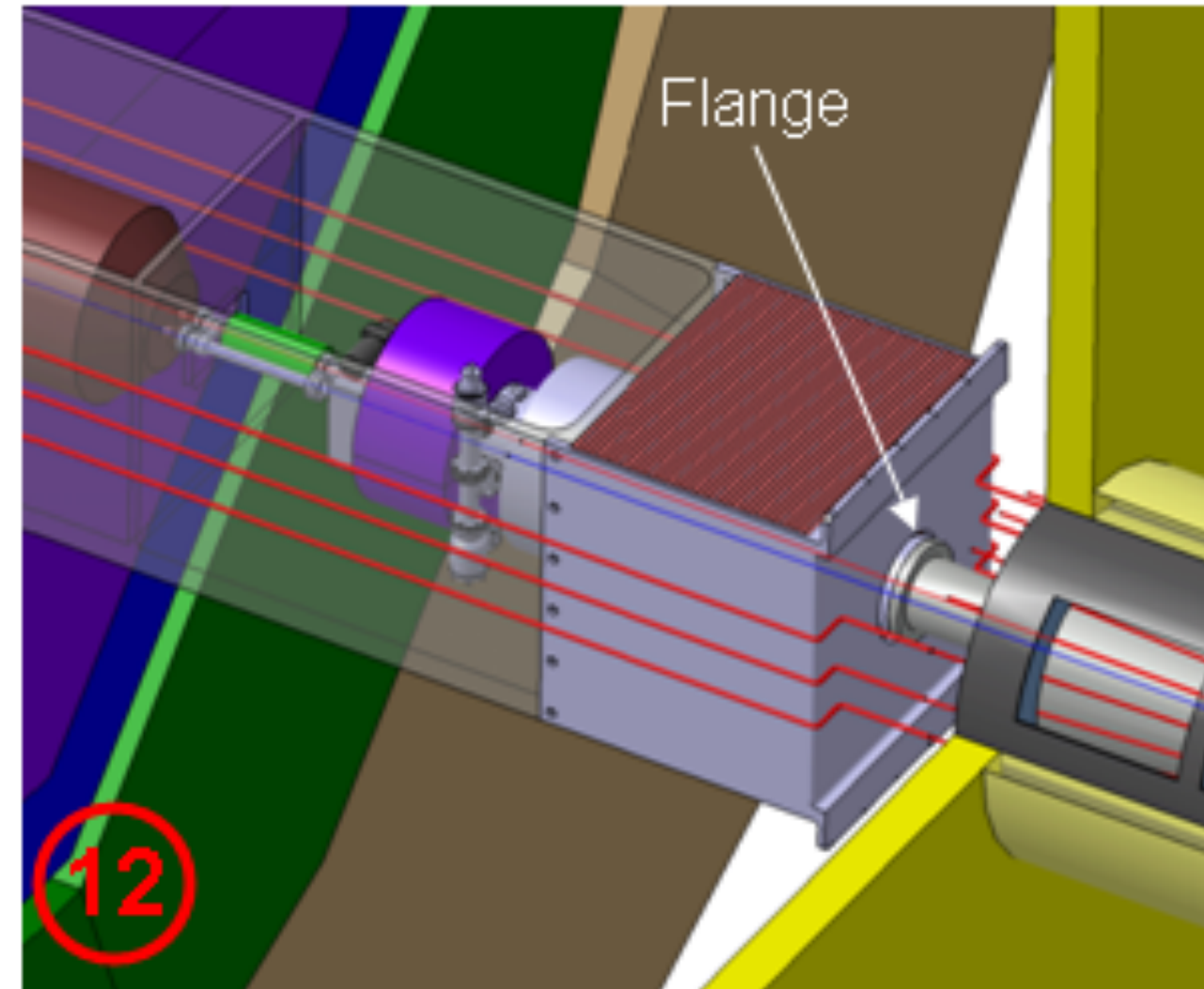

Opening in Garage Position

After beampipe has been disconnected:

- Move package of endcap and QD0 support into alcove
- Get access to all barrel detectors
- Remove inner support structure with beampipe and inner tracking detectors

Moving detector parts away from platform using air pads

- Need to study how this can be done
- Temporary floor/guidance for air pads
- Cable/actuator system requires space

Detailed planning required!

Impressions from CMS (movie)

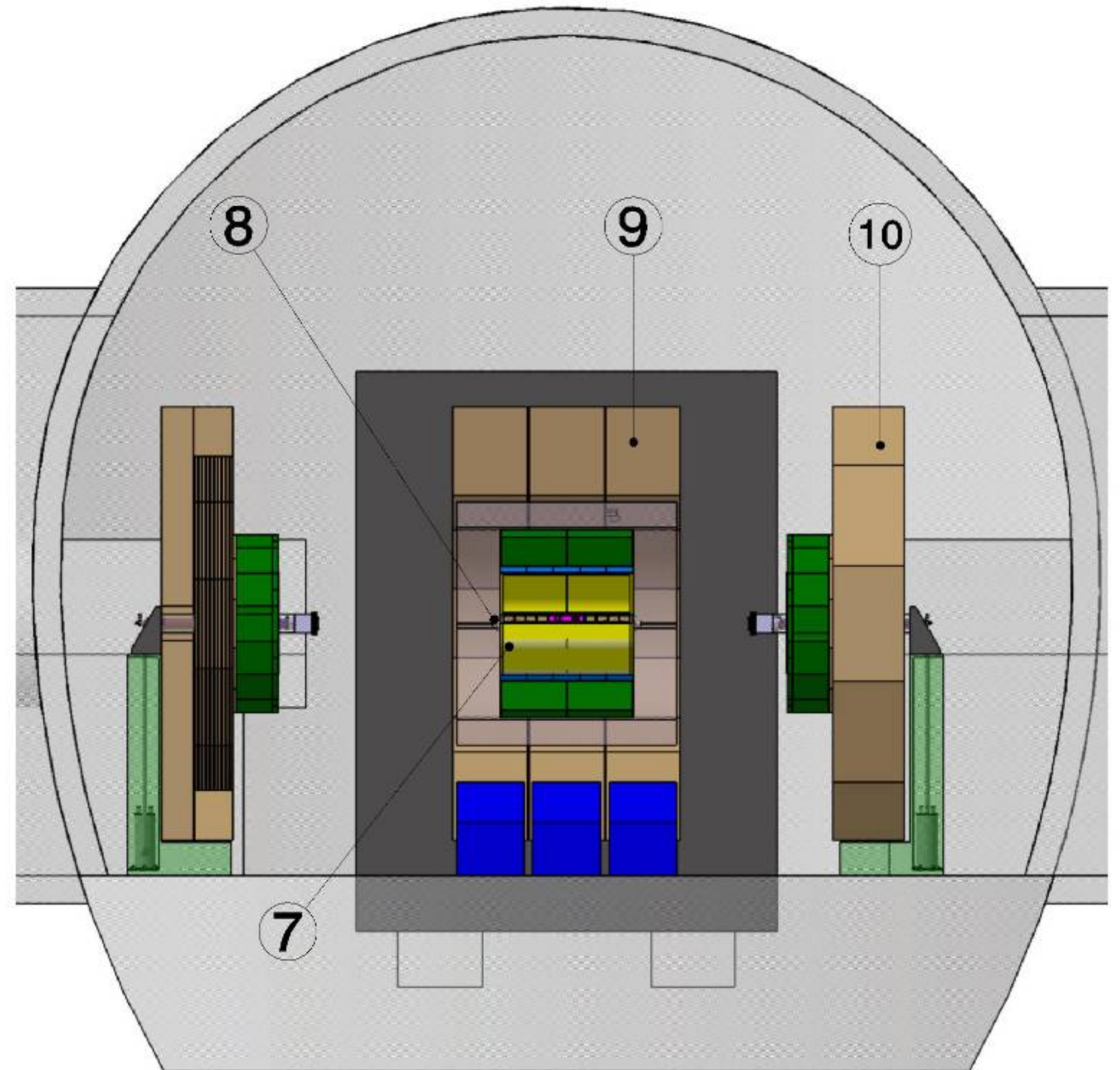

Contact

DESY.

Deutsches Elektronen-Synchrotron

Klaus Sinram

klaus.sinram@desy.de

www.desy.de